

## ANALOG PWM IC

### 1. General Description

The G1515 is a high performance AC/DC power supply controller for adapter applications requirements up to 75W. It can meet less than 80 mW standby power.

G1515 is a current mode PWM controller, It operates in fixed frequency which is precisely set internally. It could operate in Extended Burst Mode at no load or light load, in which mode switching loss is minimized and the frequency is adjusted internally. To ensure that power supplies work quietly, the frequency is set beyond 22 KHz.

Small current is needed when G1515 starts up and works, thus a large value resistor could be used in the startup circuit to minimize the standby power. Slope compensation circuit is integrated in G1515, which improves system large signal stability and reduces the possible sub-harmonic oscillation at high PWM duty cycle.

Frequency shuffling technique is integrated in G1515, which helps to achieve excellent EMI performance.

G1515 offers complete protection functions including cycle-by-cycle current limiting protection(OCP), over load protection(OLP), VDD over voltage protection(OVP), VDD over voltage clamp and under voltage lockout(UVLO).

The G1515 is available in both SOT23-6 and SOP8 package.

### Features

- ◆ Built-in Soft Start
- ◆ Random Frequency Adjustment to Reduce System EMI
- ◆ Audio Noise Reduction
- ◆ Short Circuit Protection
- ◆ Internal Cable Compensation
- ◆ Extended Burst Mode Control For Improved Efficiency and Minimum Standby Power Design
- ◆ Internal Synchronized Slope Compensation
- ◆ Low VDD Startup Current and Low Operating Current
- ◆ Leading Edge Blanking on Current Sense Input
- ◆ Over Load Protection(OLP) and Cycle-by-Cycle Current Limiting Protection(OCP)
- ◆ VDD Over Voltage Protection(OVP), Under Voltage Lockout Protection(UVLO) and Over Voltage Clamp

### Applications

- Offline AC/DC flyback converter
- Power Adapter
- Set-Top Box Power Supplies
- Open-frame SMPS
- Auxiliary Power Supply for PC and Server
- Digital Cameras and Camcorder Adapter

# G1515

## High Performance Current Mode PWM Controller

### 2. Products Information

#### 2.1 Pin configuration

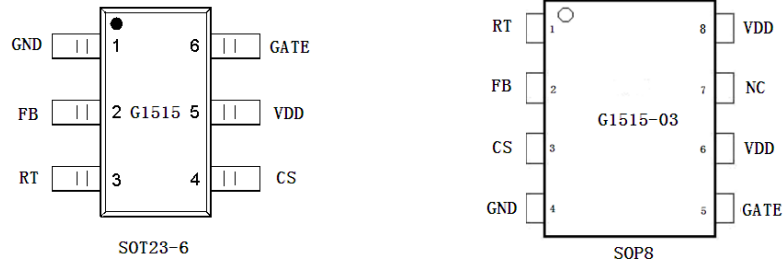

Pin Configuration: G1515 Series

Pin Name	I/O	Description
GND	P	Ground
FB	I	Feed back input Pin. The PWM duty cycle is determined by voltage level into this pin and the current-sense signal at Pin 4.
RT	I	Dual protection pin. Either connected through a NTC resistor to ground over temperature shutdown/latch control or connected through zener to VDD for adjustable over voltage protection.
CS	I	Current sense input.
VDD	P	Power supply.
Gate	O	Gate driver output.
NC		Unconnected Pin

#### 2.2 Marking Information

Part Number	Marking Information
G1515A	9AXXX
G1515B	9BXXX
G1515F	9CXXX

### 2.3 Series description

Part Number	Description
G1515A	Outside OTP with NTC, Auto Recovery, Jitter, SOT23-6
G1515A-03	Outside OTP with NTC, Auto Recovery, Jitter, SOP8
G1515B	Brown out protect, Auto Recovery, Jitter, SOT23-6
G1515F	Programmable Internal Oscillator frequency, Jitter, SOT23-6

### 2.4 Block diagram

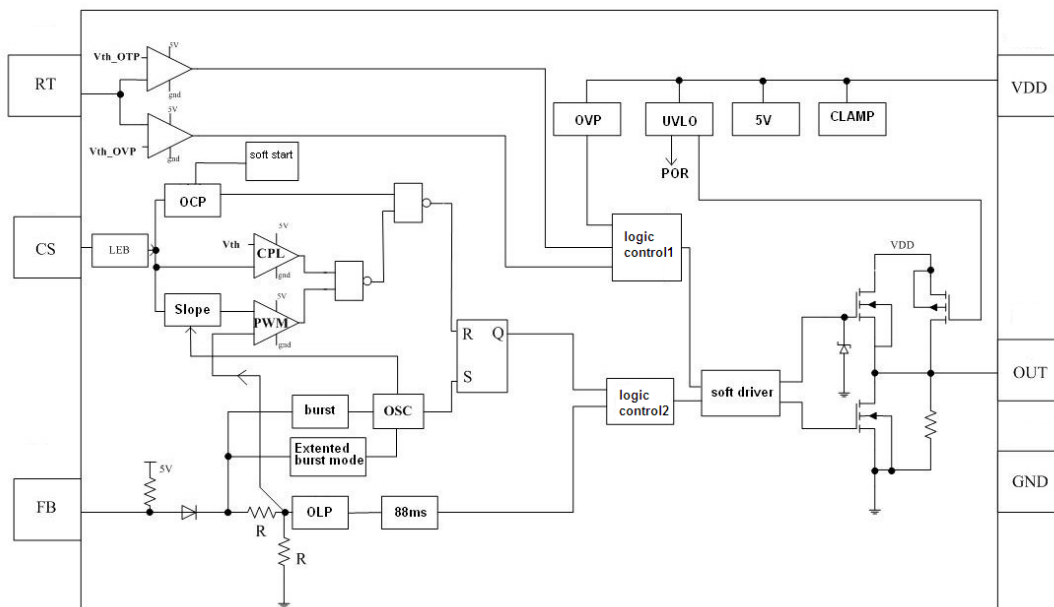

Figure2.1 G1515 Functional Block Diagram

## 3. Absolute Maximum Ratings

Description	Absolute Maximum Ratings
V <sub>DD</sub>	40 V
Supply current I <sub>VDD</sub>	10 mA
FB Input Voltage	-0.3 to 7V
Sense Input Voltage	-0.3 to 7V
RT Input Voltage	-0.3 to 7V
Min/Max Operating Junction Temperature T <sub>J</sub>	-20 to 150 °C
Min/Max Storage Temperature T <sub>STG</sub>	-55 to 160 °C
Package Dissipation R <sub>θJA</sub>	200 °C/W

# G1515

## High Performance Current Mode PWM Controller

### 4. Typical Application

The G1515 contains a controller for a flyback circuit.

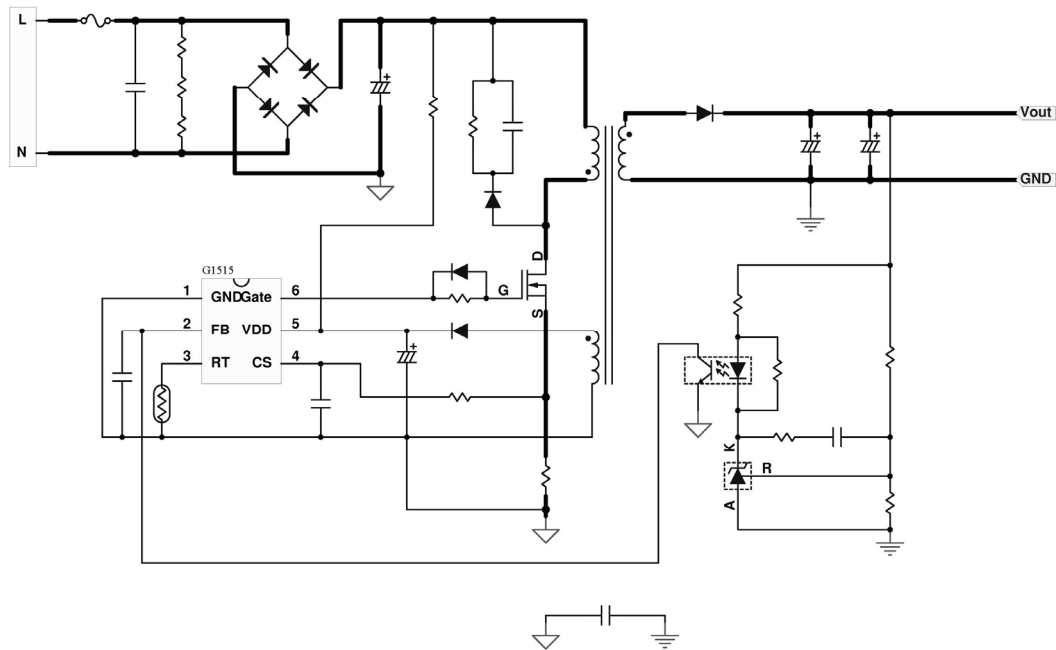

### 5. Electrical Characteristics

(TA = 25°C, VDD=16V, unless otherwise noted)

Symbol	Parameter	Test Conditions	Min	Typ	Max	Unit
<b>Supply Voltage (Pin5)</b>						
I <sub>VDD_ST</sub>	V <sub>DD</sub> Start up Current	V <sub>DD</sub> =14V, Measure Leakage current into V <sub>DD</sub>		3	10	uA
I <sub>operate</sub>	Operation Current	V <sub>FB</sub> =3V		1.6	2.5	mA
V <sub>UVLO(off)</sub>	V <sub>DD</sub> Under Voltage Lockout exit		14.5	15.5	16.5	V
V <sub>UVLO(on)</sub>	V <sub>DD</sub> Under Voltage Lockout enter		8	9	10	V
V <sub>DD_CLAMP</sub>	V <sub>DD</sub> clamp	I <sub>DD</sub> =10mA	30	31	32	V
V <sub>DD_OVP</sub>	V <sub>DD</sub> ovp		27	28	29	V

Symbol	Parameter	Test Conditions	Min	Typ	Max	Unit
<b>Feedback (Pin2)</b>						
V <sub>FB_OPEN</sub>	V <sub>FB</sub> Open Loop Voltage		4.5	5		V
D <sub>MAX</sub>	Max duty cycle	V <sub>DD</sub> =14V, V <sub>FB</sub> =3V, V <sub>CS</sub> =0V	75	80	85	%
I <sub>FB_SHORT</sub>	FB pin short circuit current			0.3		mA
V <sub>Ref_burst_H</sub>	The threshold exit burst mode			1.2		V
V <sub>Ref_burst_L</sub>	The threshold enter burst mode			1.1		V
V <sub>TH_PL</sub>	Power Limiting FB Threshold			3.7		V
T <sub>D_PL</sub>	Power limiting Debounce time		80	88	96	ms
Z <sub>FB_IN</sub>	Input Impedance			16		KΩ
<b>Current sense (Pin4)</b>						
SST	Soft start time			6		ms
T <sub>LEB</sub>	Leading edge blanking time			300		ns
Z <sub>SENSE_IN</sub>	Input Impedance			40		KΩ
V <sub>TH_OC</sub>	Internal Current Limiting			0.75		V
<b>Oscillator</b>						
F <sub>OSC</sub>	Normal Oscillation Frequency	V <sub>FB</sub> =3V, V <sub>CS</sub> =0V	60	65	70	KHz
ΔF <sub>OSC</sub>	Jitter frequency		-4		4	%
ΔF <sub>Temp</sub>	Frequency Temperature Stability			1		%
ΔF <sub>VDD</sub>	Frequency Voltage Stability			1		%
F <sub>BURST</sub>	Burst Mode Base Frequency			22		KHz
<b>Gate driver (Pin6)</b>						
V <sub>OL</sub>	Gate Output Low Level	I <sub>o</sub> =5mA			1	V
V <sub>OH</sub>	Gate Output High Level	I <sub>o</sub> =20mA	6			V
V <sub>CLAMP</sub>	Gate Output clamp voltage			14		V
T <sub>r</sub>	Gate rising time	C <sub>load</sub> =1nf		120		nSec
T <sub>f</sub>	Gate falling time	C <sub>load</sub> =1nf		80		nSec
<b>Protection</b>						
I <sub>RT</sub>	Output current of RT pin		45	50	55	uA
V <sub>OTP</sub>	Threshold voltage for OTP		0.95	1	1.05	V
V <sub>RT_OPEN</sub>	Float voltage at RT pin			2.3		V
V <sub>TH_OVP</sub>	External OVP threshold voltage			4		V

# G1515

## High Performance Current Mode PWM Controller

### 6. CHARACTERIZATION

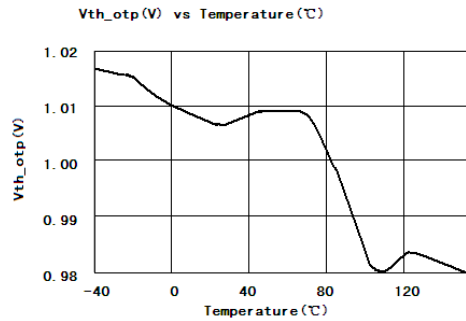

Figure 6.1 Vth\_otp(V) vs Temperature(°C)

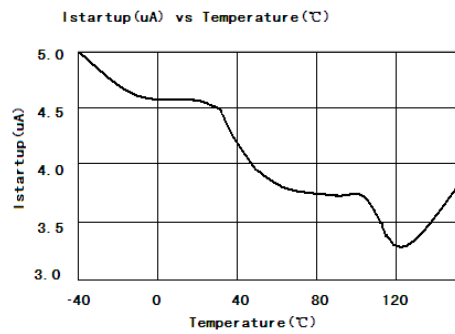

Figure 6.2 Istartup(uA) vs Temperature(°C)

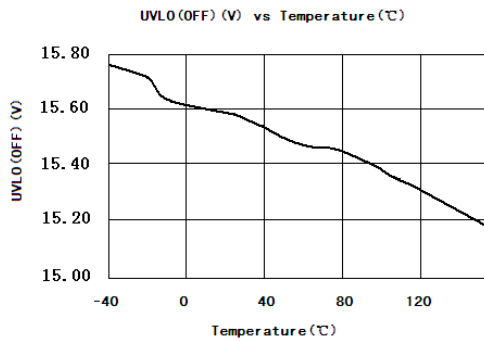

Figure 6.3 UVLO(OFF)(V) vs Temperature(°C)

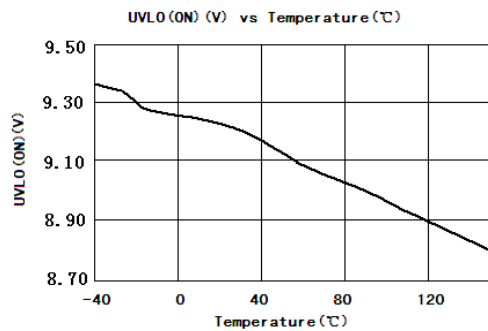

Figure 6.4 UVLO(ON)(V) vs Temperature(°C)

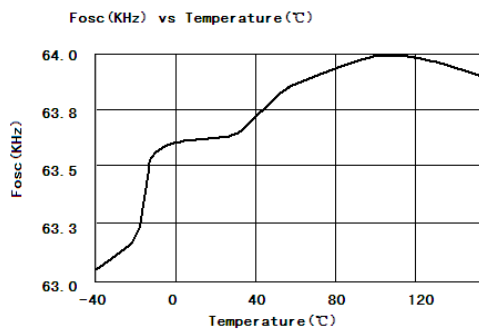

Figure 6.5 Fosc(KHz) vs Temperature(°C)

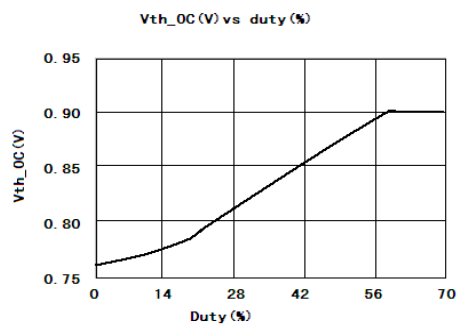

Figure 6.6 Vth\_OC(V) vs Temperature(°C)

## 7. OPERATION DESCRIPTION

The G1515 is a low power off-line SMPS Switcher optimized for off-line flyback converter applications in up to 75W power range. The 'Extended burst mode' control greatly reduces the standby power consumption and helps the design easily to meet the international power conservation requirements.

- Startup Current and Start up Control

Startup current of G1515 is designed to be very low so that VDD could be charged up above UVLO threshold level and device starts up quickly. A large value startup resistor can therefore be used to minimize the power loss yet achieve a reliable startup in application. For AC/DC adapter with universal input range design, a 2 M $\Omega$ , 1/8 W startup resistor could be used together with a VDD capacitor to provide a fast startup and yet low power dissipation design solution.

- Operating Current

The Operating current of G1515 is low at 1.8mA. Good efficiency is achieved with G1515 low operating current together with the 'Extended burst mode' control features.

- Soft Start

G1515 features an internal 4ms soft start to soften the electrical stress occurring in the power supply during startup. It is activated during the power on sequence. As soon as VDD reaches UVLO(OFF), the CS peak voltage is gradually increased from 0.15V to the maximum level. Every restart up is followed by a soft start.

- Frequency shuffling for EMI improvement

The frequency Shuffling (switching frequency modulation) is implemented in G1515. The oscillation frequency is modulated so that the tone energy is spread out. The spread spectrum minimizes the conduction band EMI and therefore eases the system design.

- Extended Burst Mode Operation

At light load or zero load condition, most of the power dissipation in a switching mode power supply is from switching loss on the MOSFET, the core loss of the transformer and the loss on the snubber circuit. The magnitude of power loss is in proportion to the switching frequency. Lower switching frequency leads to the reduction on the power loss and thus conserves the energy.

The switching frequency is internally adjusted at no load or light load condition. The switch frequency reduces at light/no load condition to improve the conversion efficiency. At light load or no load condition, the FB input drops below burst mode threshold level and device enters Burst Mode control. The Gate drive output switches only when VDD voltage drops below a preset level and FB input is active to output an on state. Otherwise the gate drive remains at off state to minimize the switching loss and reduces the standby power consumption to the greatest extend. The switching frequency control also eliminates the audio noise at any loading conditions.

- Oscillator Operation

The switching frequency of G1515 is internally fixed at 65KHZ. No external frequency setting components are required for PCB design simplification.

## **G1515**

### ***High Performance Current Mode PWM Controller***

---

- **Current Sensing and Leading Edge Blanking**

Cycle-by-Cycle current limiting is offered in G1515 current mode PWM control. The switch current is detected by a sense resistor into the sense pin. An internal leading edge blanking circuit chops off the sensed voltage spike at initial internal power MOSFET on state due to snubber diode reverse recovery and surge gate current of power MOSFET so that the external RC filtering on sense input is no longer needed. The current limiting comparator is disabled and cannot turn off the internal power MOSFET during the blanking period. The PWM duty cycle is determined by the current sense input voltage and the FB input voltage.

- **Internal Synchronized Slope Compensation**

Built-in slope compensation circuit adds voltage ramp onto the current sense input voltage for PWM generation. This greatly improves the close loop stability at CCM and prevents the sub-harmonic oscillation and thus reduces the output ripple voltage.

- **Drive**

The power MOSFET is driven by a dedicated gate driver for power switch control. Too weak the gate drive strength results in higher conduction and switch loss of MOSFET while too strong gate drive results the compromise of EMI. A good trade off is achieved through the built-in totem pole gate design with right output strength and dead time control. The low idle loss and good EMI system design is easier to achieve with this dedicated control scheme.

- **Protection Controls**

Good power supply system reliability is achieved with auto-recovery protection features including Cycle-by-Cycle current limiting (OCP), Over Load Protection (OLP), CS short protection, CS floating protection, and Under Voltage Lockout on VDD (UVLO), and latch features including over temperature protection (OTP), fixed or adjustable over voltage protection (OVP). With GlobalSemi Proprietary technology, the OCP is line voltage compensated to achieve constant output power limit over the universal input voltage range.

At overload condition when FB input voltage exceeds power limit threshold value for more than TD\_PL, control circuit reacts to shut down the switcher. Switcher restarts when VDD voltage drops below UVLO limit. For latch mode, control circuit shutdowns (latch) the power MOSFET when an Over Temperature condition or Over Voltage condition is detected until VDD drops below 5V (Latch release voltage) , and device enters power on restart-up sequence there after.



## 8. Package Information

SOT23-6

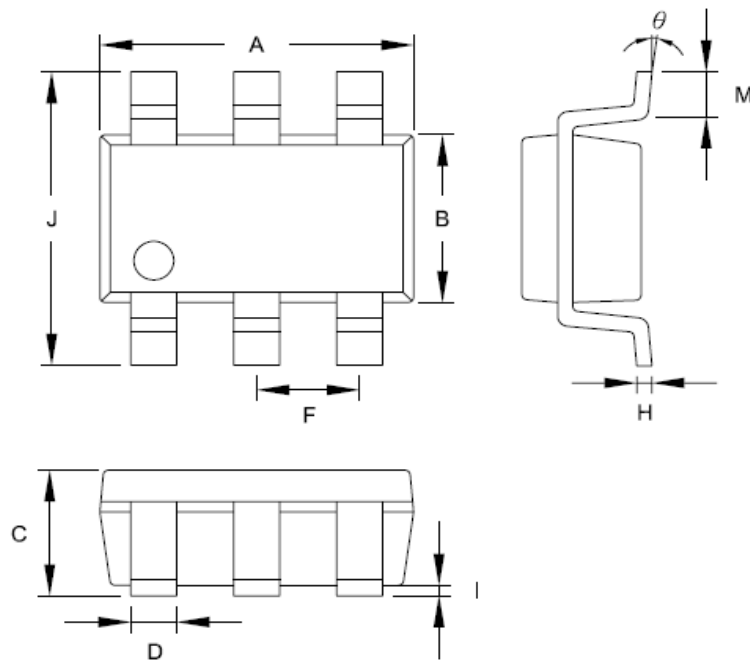

Symbol	Dimension in Millimeters		Dimensions in Inches	
	Min	Max	Min	Max
A	2.692	3.099	0.106	0.122
B	1.397	1.803	0.055	0.071
C	--	1.450	--	0.057
D	0.300	0.500	0.012	0.020
F	0.95		0.037	
H	0.080	0.254	0.003	0.010
I	0.050	0.150	0.002	0.006
J	2.600	3.000	0.102	0.118
M	0.300	0.600	0.012	0.024
θ	0°	10°	0°	10°

# G1515

## High Performance Current Mode PWM Controller

8 -Pin Plastic SOP

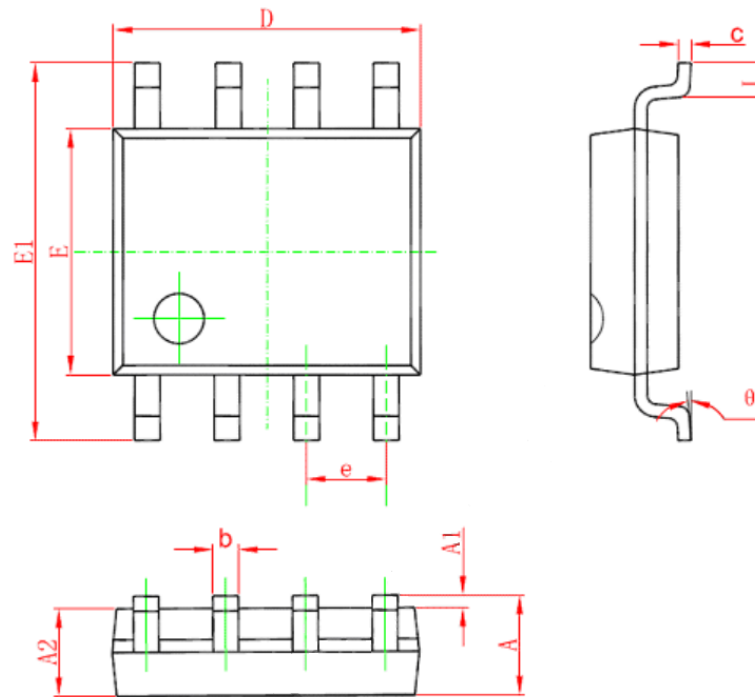

Symbol	Dimension in Millimeters		Dimensions in Inches	
	Min	Max	Min	Max
A	1.350	1.750	0.053	0.069
A1	0.050	0.250	0.002	0.010
A2	1.250	1.650	0.049	0.065
b	0.310	0.510	0.012	0.020
c	0.100	0.250	0.004	0.010
D	4.700	5.150	0.185	0.203
E	3.800	4.000	0.150	0.157
E1	5.800	6.200	0.228	0.244
e	1.270(BSC)		0.050(BSC)	
L	0.400	1.270	0.016	0.050
θ	0°	8°	0°	8°

Data and specifications subject to change without notice.

This product has been designed and qualified for Industrial Level and Lead-Free.

Qualification Standards can be found on GS's Web site.

Global Semiconductor HEADQUARTERS:

Scotia Centre, 4<sup>th</sup> Floor, P.O. Box 2804, George Town, Grand Cayman KY1-1112, Cayman

Visit us at [www.globalsemi-group.com](http://www.globalsemi-group.com) for sales contact information.



Global Semiconductor

