



DESCRIPTION

The A7525 is synchronous, fixed frequency, step-up DC/DC converters delivering high efficiency in a 6-lead SOT package. Capable of supplying 3.3V at 100mA from a single AA cell input, the device contain an internal NMOS switch and PMOS synchronous rectifier. A switching frequency of 1.2MHz minimizes solution footprint by allowing the use of tiny, low profile inductors and ceramic capacitors. The current mode PWM design is internally compensated, reducing external parts count.

The A7525 features continuous switching at light loads. Anti-ringing control circuitry reduces EMI concerns by damping the inductor in discontinuous mode, and the device features low shutdown current of under 1uA.

The A7525 is available in SOT-26 package.

ORDERING INFORMATION

Package Type	Part Number	
SOT-26	E6	A7525E6R-ADJ
		A7525E6VR-ADJ
Note	V: Halogen free Package R : Tape & Reel	
AiT provides all RoHS products Suffix " V " means Halogen free Package		

FEATURES

- High Efficiency: Up to 92%
- 1.2MHz Constant Switching Frequency
- 3.3V Output Voltage at I_{OUT}=100mA from a Single AA Cell; 5.0V Output Voltage at I_{OUT}=500mA from one Li battery.
- Low Start-up Voltage: 1.0V
- Integrated main switch and synchronous rectifier.
- No Schottky Diode Required
- 2.5V to 5V Output Voltage Range
- Automatic Pulse Skipping Mode Operation
- Tiny External Components
- <1μA Shutdown Current
- Anti-ringing Control Reduces EMI
- Available in SOT-26 Package

APPLICATION

- Cellular and Smart Phones
- Microprocessors and DSP Core Supplies
- Wireless and DSL Modems
- MP3 Player
- Digital Still and Video Cameras
- Portable Instruments

TYPICAL APPLICATION CIRCUIT

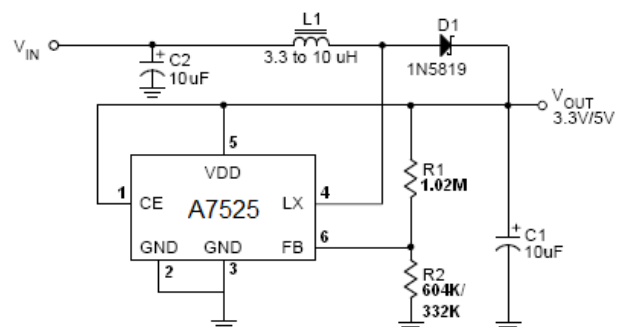



PIN DESCRIPTION

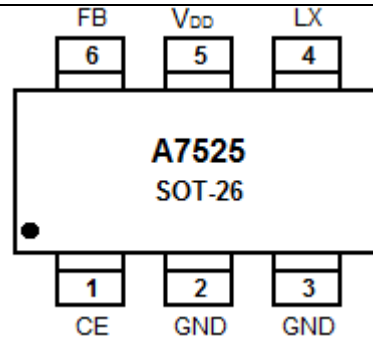

Top View

Pin #	Symbol	Function
1	CE	Chip Shutdown Signal Input. Logic high is normal operation mode, Logic Low is Shutdown
2,3	GND	Ground
4	LX	Power Switch Pin. It is the switch node connection to Inductor
5	V _{DD}	Power Output Pin
6	FB	Feedback Input Pin. Connect FB to the center point of the external resistor divider. The feedback threshold voltage is 1.23V



ABSOLUTE MAXIMUM RATINGS

Input Voltage	-0.3V ~ +6V
FB, CE Voltage	-0.3V ~ +6V
V _{DD} Voltage	-0.3V ~ +6V
Operating Temperature, T _{OPR} ^{NOTE1}	-40°C ~ +85°C
Storage Temperature Range	-65°C ~ +150°C
Lead Temperature (Soldering, 10sec)	+300°C

Stresses above may cause permanent damage to the device. These are stress ratings only and functional operation of the device at these or any other conditions beyond those indicated in the Electrical Characteristics are not implied. Exposure to absolute maximum rating conditions for extended periods may affect device reliability.

NOTE1: T_J is calculated from the ambient temperature T_A and power dissipation P_D according to the following formula:

$$T_J = T_A + (P_D) \times (250^\circ\text{C/W})$$

THERMAL RESISTANCE

Package	θ_{JA}	θ_{JC}
SOT-26	250°C/W	110°C/W



ELECTRICAL CHARACTERISTICS

$V_{IN} = 1.2V$, $V_{OUT} = 3.3V$, $T_A = 25^\circ C$, unless otherwise specified

Parameter	Condition	Min.	Typ.	Max.	Unit
Minimum Start-Up Voltage	$I_{OUT} = 1mA$	-	1	-	V
Minimum Operating Voltage	$V_{CE} = V_{IN}$	-	0.8	-	V
Output Voltage Range		2.5	-	5	V
Feedback Voltage	$-40^\circ C \leq T_A \leq 85^\circ C$	1.192	1.230	1.268	V
Quiescent Current(Shutdown)	$V_{SHDN} = 0V$		0.01	1	μA
Quiescent Current(Active)	Measured on V_{OUT}		300	500	μA
NMOS Switch Leakage	$V_{SW} = 5V$	-	0.1	5	μA
PMOS Switch Leakage	$V_{SW} = 0V$	-	0.1	5	μA
NMOS Switch ON Resistance	$V_{OUT} = 3.3V$		0.40	-	Ω
	$V_{OUT} = 5V$	-	0.35	-	Ω
PMOS Switch ON Resistance	$V_{OUT} = 3.3V$	-	0.70	-	Ω
	$V_{OUT} = 5V$	-	0.60	-	Ω
Output Voltage	$V_{OUT} = 3.3V, I_{OUT} = 1mA$	3.201	3.300	3.399	V
	$V_{OUT} = 5V, I_{OUT} = 1mA,$ $V_{IN} = 2.4V$	4.850	5.000	5.150	V
Line Regulation	$V_{IN} = 0.8V$ to $3.0V,$ $I_{OUT} = 10mA$	-	1	-	%/V
Load Regulation	$I_{OUT} = 1mA$ to $100mA$	-	0.02	-	%/mA
NMOS Current Limit		600	850	-	mA
Current Limit Delay to Output	Note 2	-	40	-	ns
Max Duty Cycle	$V_{FB} = 1.15V,$ $-40^\circ C \leq T_A \leq 85^\circ C$	80	85	-	%
Switching Frequency		0.95	1.2	1.5	MHz
	$-40^\circ C \leq T_A \leq 85^\circ C$	0.85	1.2	1.5	MHz
CE Input Threshold		0.35	0.60	1.50	V
CE Input Current	$V_{CE} = 5.5V$		0.01	1	μA

NOTE2: Guaranteed by design



TYPICAL PERFORMANCE CHARACTERISTICS

1. Efficiency vs. Output Current
 $V_{OUT}=3.3V$, $T_A = 25^\circ C$

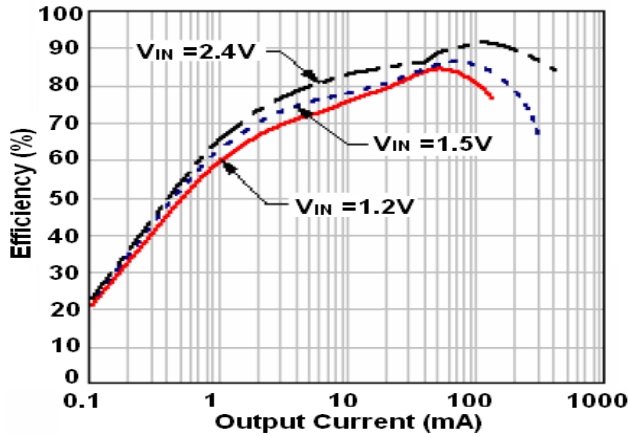

2. Input current vs. Output current
 $V_{OUT}=5.0V$, $T_A = 25^\circ C$

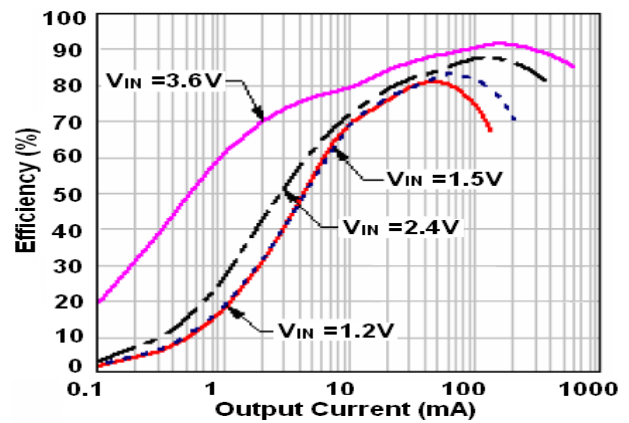

3. Output Voltage vs. Output Current
 $V_{OUT}=3.3V$, $T_A = 25^\circ C$

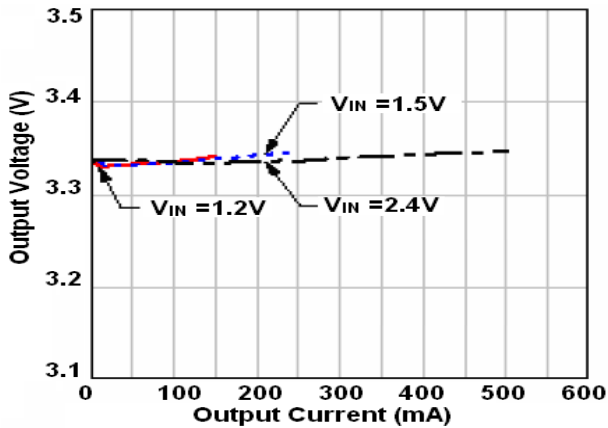

4. Output Voltage vs. Output Current
 $V_{OUT}=5.0V$, $T_A = 25^\circ C$

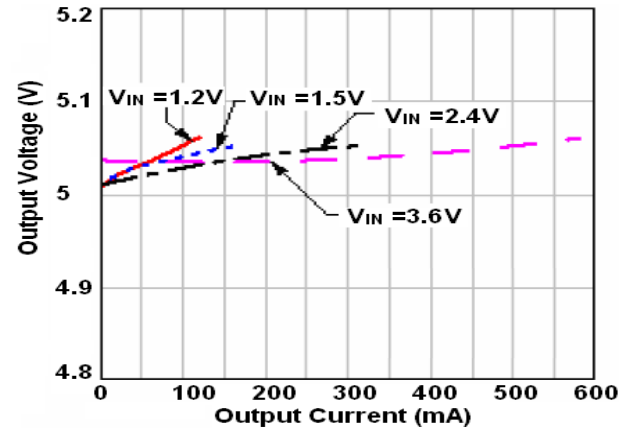

5. Minimum Start-Up Voltage vs. Output Current
 $V_{OUT}=3.3V$, $T_A = 25^\circ C$

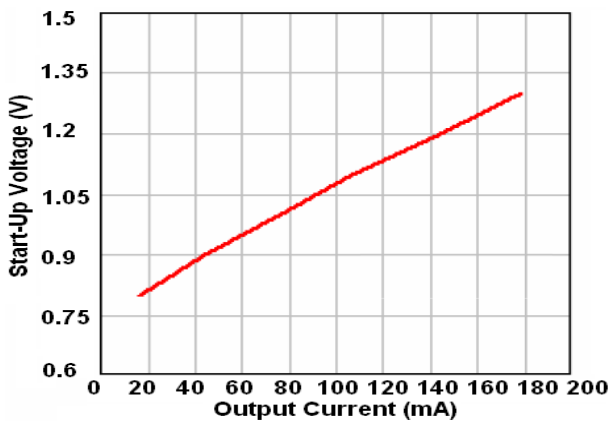

6. Maximum Output Current vs. Input Voltage
 $L=4.7\mu H$, $T_A = 25^\circ C$

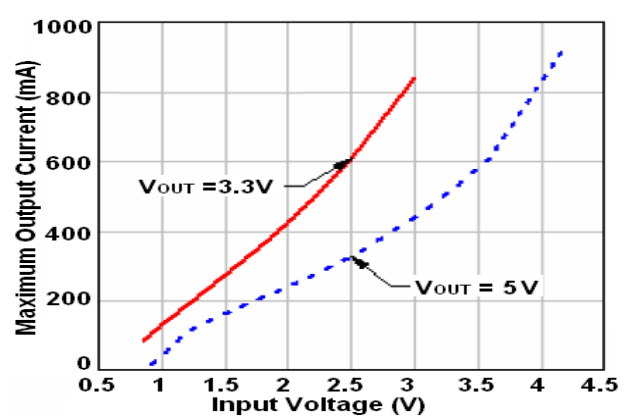



7. No Load Input Current vs. Input Voltage
 $V_{OUT}=3.3V$, $T_A = 25^{\circ}C$, No Load

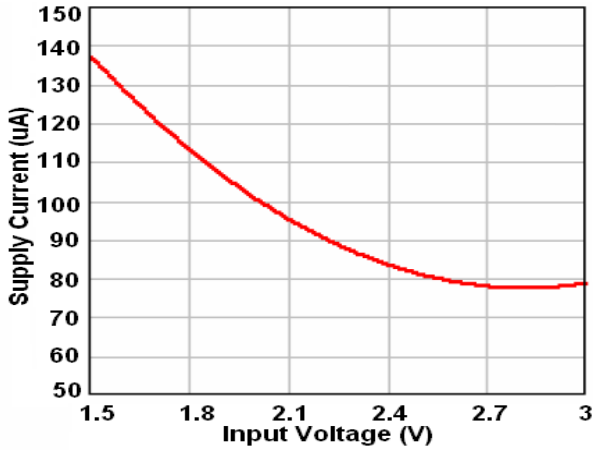

8. V_{OUT} vs. Temperature

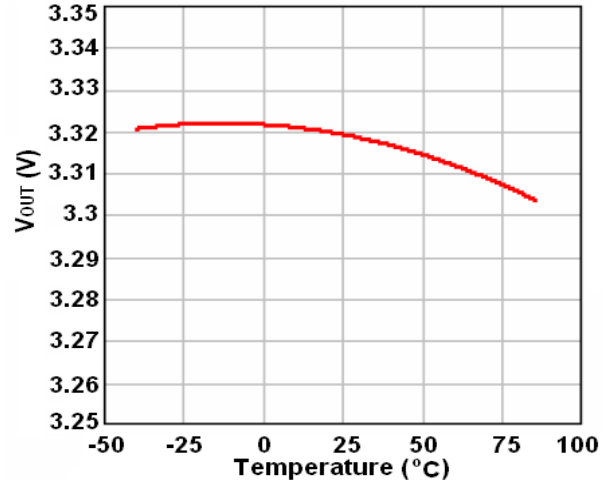

9. Pulse Skipping Mode operation

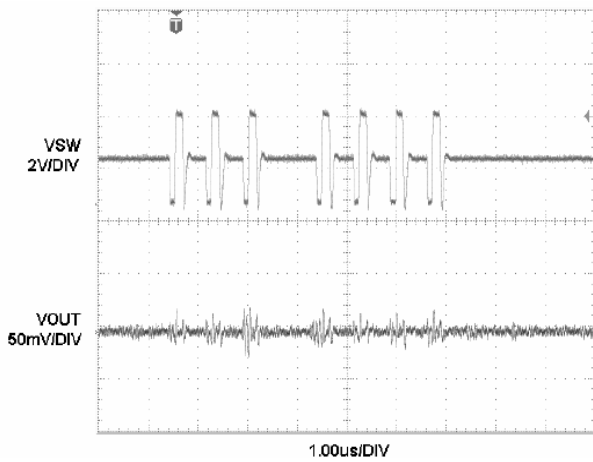

10. Antiringing Operation at SW

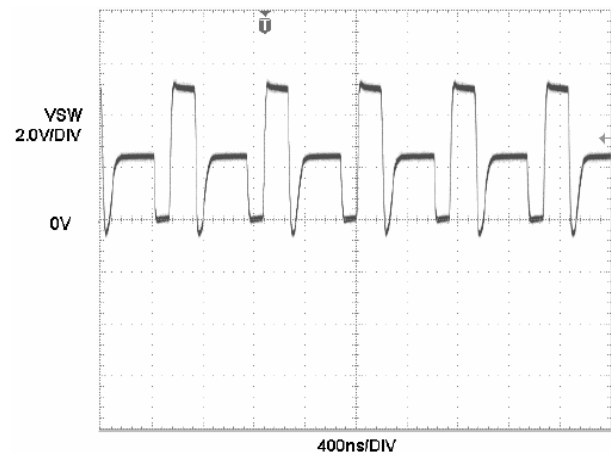

11. Load Transient Response

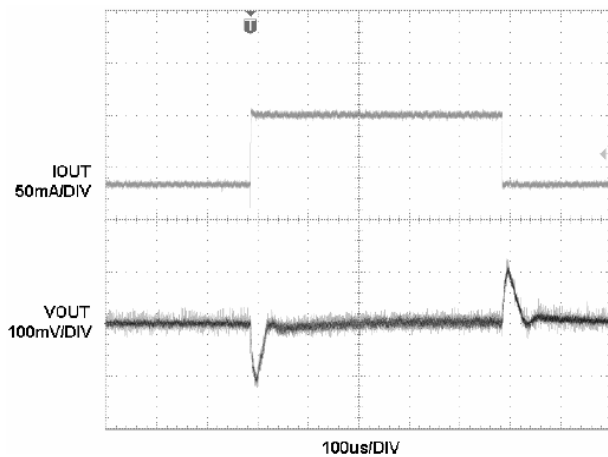



BLOCK DIAGRAM

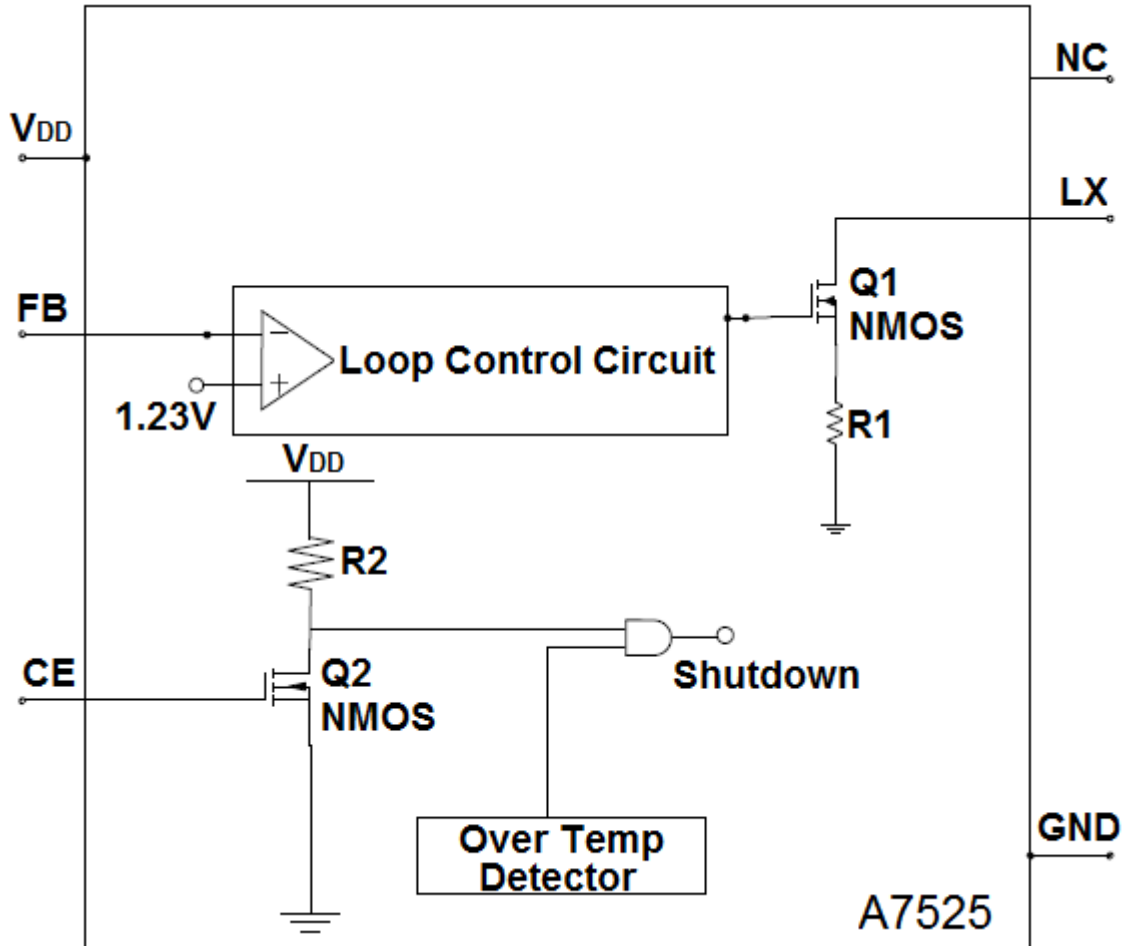



DETAILED INFORMATION

Operation

The A7525 is 1.2MHz, synchronous boost converter housed in SOT-26 package. Able to operate from an input voltage 1V, the device features fixed frequency, current mode PWM control for exceptional line and load regulation. With its low RDS (ON) and gate charge internal MOSFET switches, the device maintains high efficiency over a wide range of load current. Detailed descriptions of the operating modes follow. Operation can be best understood by referring to the Block Diagram.

Synchronous Rectification

The A7525 integrates a synchronous rectifier to improve efficiency as well as to eliminate the external Schottky diode. The synchronous rectifier is used to reduce the conduction loss contributed by the forward voltage of Schottky diode. The synchronous rectifier is realized by a P-ch MOSFET with gate control circuitry that incorporates relatively complicated timing concerns.

Low Voltage Start-Up

The A7525 will start up at a typical V_{IN} of 1.0V or higher. The low voltage start-up circuitry controls the internal NMOS switch up to a maximum peak inductor current of 850mA (typical), with an approximate 1.5us off-time during start-up, allowing the devices to start up into an output load. Once V_{OUT} exceeds 2.3V, the start-up circuitry is disabled and normal fixed frequency PWM operation is initiated. In this mode, the A7525 operate allowing extended operating time as the battery can droop to several tenths of a volt without affecting output voltage regulation. The limiting factor for the application becomes the ability of the battery to supply sufficient energy to the output.

Low Noise Fixed Frequency Operation

Oscillator: The frequency of operation is internally set to 1.2MHz. **Error Amp:** The error amplifier is an internally compensated trans-conductance type (current output) with a trans-conductance (gm) = 33 micro-siemens. The internal 1.23V reference voltage is compared to the voltage at the FB pin to generate an error signal at the output of the error amplifier. A voltage divider from V_{OUT} to ground programs the output voltage via FB from 2.5V to 5V using the equation:

$$V_{OUT} = 1.23V \times [1 + (R1/R2)]$$



Current Sensing: A signal representing NMOS switch current is summed with the slope compensator.

The summed signal is compared to the error amplifier output to provide a peak current control command for the PWM. Peak switch current is limited to approximately 850mA independent of input or output voltage. The current signal is blanked for 40ns to enhance noise rejection.

Zero Current Comparator: The zero current comparator monitors the inductor current to the output and shuts off the synchronous rectifier once this current reduces to approximately 20mA. This prevents the inductor current from reversing in polarity improving efficiency at light loads.

Antiringing Control: The antiringing control circuitry pre-vents high frequency ringing of the LX pin as the inductor current goes to zero by damping the resonant circuit formed by L and CLX (capacitance on LX pin).

Pulse Skipping Mode

At very light load, the A7525 automatically switches into Pulse Skipping Mode to improve efficiency. During this mode, the PWM control will skip some pulses to maintain regulation. If the load increases and the output voltage drops, the device will automatically switch back to normal PWM mode and maintain regulation.

Device Shutdown

When CE is set logic high, the A7525 is put into operation. If CE is set logic low, the device is put into shutdown mode and consumes lower than 1µA current. After start-up timing, the internal circuitry is supplied by V_{OUT}, however, if shutdown mode is enabled, the internal circuitry will be supplied by battery again.

Application

Setting the Output Voltage: An external resistor divider is used to set the output voltage. The output voltage of the switching regulator (V_{OUT}) is determined by the following equation:

$$V_{OUT} = 1.23V \times [1 + (R1/R2)]$$

Table 1 list the resistor selection for output voltage setting.

Table 1 Resistor selection for output voltage setting

V _{OUT}	R1(Ω)	R2(Ω)
3.3V	1.02M	604K
5.0V	1.02M	332K



Inductor Selection: The high switching frequency of 1.2MHz allows for small surface mount inductors. For most designs, the A7525 operates with inductors of 4.7μH to 10μH. The equation below can help to select the inductor, the maximum output current can be get by this equation; where η is the efficiency, I_{PEAK} is the peak current limit, f is the switching frequency, L is the inductance value and D is the duty cycle.

$$I_{OUT} = \eta \times \left[I_{PEAK} - \frac{V_{IN} \times D}{2 \times f \times L} \right] \times (1-D)$$

Larger inductors mean less inductor current ripple and usually less output voltage ripple. Larger inductors also mean more load power can be delivered. But large inductors are also with large profile and costly. The inductor ripple current is typically set for 20% to 40% of the maximum inductor current. When selecting an inductor, the DC current rating must be high enough to avoid saturation at peak current. For optimum load transient and efficiency, the low DCR should be selected. Table 2 lists some typical surface mount inductors that meet target applications for the A7525:

Table2. Typical Surface Mount Inductors

Part Number	L(μH)	Max DCR (mΩ)	Rated D.C. Current (A)	Size WxLxH (mm)
Sumida CR43	4.7 10	108.7 182	1.15 1.04	4.3x4.8x3.5
Sumida CDRH4D28	4.7 5.6 6.8 10	72 101 109 128	1.32 1.17 1.12 1.00	5.0x5.0x3.0
Toko D53LC	4.7 6.8 10	45 68 90	1.87 1.51 1.33	5.0x5.0x3.0

Output Capacitor Selection: The output capacitor is required to keep the output voltage ripple small and to ensure regulation loop stability. A 2.2μF to 10μF output capacitor is sufficient for most applications. If output capacitor is larger than 10μF, a phase lead capacitor must be included to maintain enough phase margin. The output capacitor must have low impedance at the switching frequency. Ceramic capacitors with X5R or X7R dielectrics are recommended due to their low ESR and high ripple current ratings.



Input Capacitor Selection: The input capacitor reduces the surge current drawn from the input and switching noise from the device. A minimum 4.7 μ F input capacitor is needed for most applications. The input capacitor impedance at the switching frequency should be less than input source impedance to prevent high frequency switching current passing to the input. A low ESR input capacitor sized for maximum RMS current must be used. Ceramic capacitors with X5R or X7R dielectrics are highly recommended because of their low ESR and small temperature coefficients.

Output Diode Selection: An Schottky diode should be included when the output voltage is above 4.5V. The Schottky diode is optional for the output voltage not more than 4.5V, but can improve efficiency by about 2% to 3%.

PCB Layout Guidance

The A7525 operates at 1.2MHz typically. This is a considerably high frequency for DC-DC converters. In such case PCB layout is important to guarantee satisfactory performance. It is recommended to make traces of the power loop, especially where switching node is involved as short and wide as possible. First of all, the inductor, input and output capacitor should be close to the device. Feedback and shut down circuit should avoid the proximity of large AC signals, e.g. the power inductor and switching nodes. The optional rectifier diode (D1) can improve efficiency and alleviate the stress on the integrated MOSFET. The diode should also be close to the inductor and the chip to form the shortest possible switching loop. Large and integral multi layer ground planes are ideal for high power applications. Large area of copper has lower resistance and helps to dissipate heat on the device. The converter's ground should join the system ground to which it supplies power at one point only.



PACKAGING INFORMATION

Dimension in SOT-26 (Unit: mm)

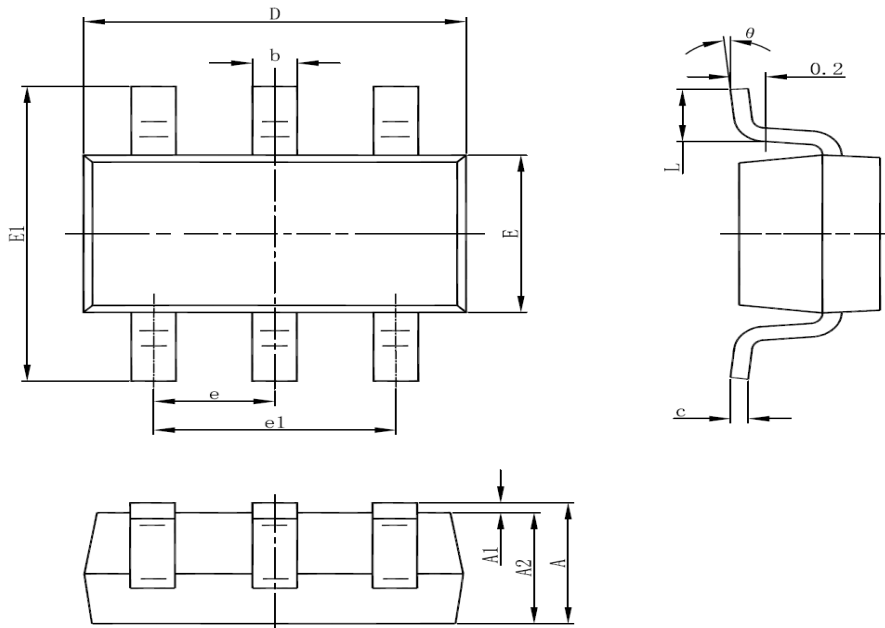

SYMBOL	MIN	MAX
A	1.100	1.300
A1	0.010	0.130
A2	1.000	1.170
b	0.300	0.500
c	0.090	0.200
D	2.800	3.100
E	1.500	1.700
E1	2.500	3.100
e	0.950(RFE)	
e1	1.900(RFE)	
L	0.350	0.800
θ	0°	10°



IMPORTANT NOTICE

AiT Semiconductor Inc. (AiT) reserves the right to make changes to any its product, specifications, to discontinue any integrated circuit product or service without notice, and advises its customers to obtain the latest version of relevant information to verify, before placing orders, that the information being relied on is current.

AiT Semiconductor Inc.'s integrated circuit products are not designed, intended, authorized, or warranted to be suitable for use in life support applications, devices or systems or other critical applications. Use of AiT products in such applications is understood to be fully at the risk of the customer. As used herein may involve potential risks of death, personal injury, or severe property, or environmental damage. In order to minimize risks associated with the customer's applications, the customer should provide adequate design and operating safeguards.

AiT Semiconductor Inc. assumes to no liability to customer product design or application support. AiT warrants the performance of its products of the specifications applicable at the time of sale.