

PWM Step-Up DC/DC Converter for Panel Backlight

General Description

The EMD2050 designed with high efficiency step up DC/DC converter for driving white LEDs. The device can drive up 3 white LEDs from a single Li-Ion battery or a DC power 2.5V to 5.5V. The EMD2050 uses current mode and pulse-width modulated (PWM) operation. It switches at 1.2MHz and allows using small inductor and both of input/output capacitors. An internal compensation can reduce external component.

The EMD2050 include under-voltage lockout, current limit, over voltage and thermal shutdown protection. The EMD2050 is available in SOT-26 package.

Features

- WLEDs supports (20mA for each channel):
 - Up to 3S13P at VIN=3.7V
 - Up to 3S18P at VIN=5.0V
 (Note: S→ Series; P→ Parallel)
- Low Quiescent Current: 55 μ A
- Over Voltage Protection: 15V
- Inherently Matched LED Current
- Shutdown Current < 1 μ A
- Reference Voltage 0.235V
- Efficiency : 85% (Typ) at VIN=5.0V
- PWM Dimming Control
- Internal Soft Start and Compensation
- Low Profile SOT-26 Package

Applications

- Mobile Phone
- Digital Still Cameras
- Portable applications
- MP3 Players
- GPS Receivers

Typical Application (3S13P)

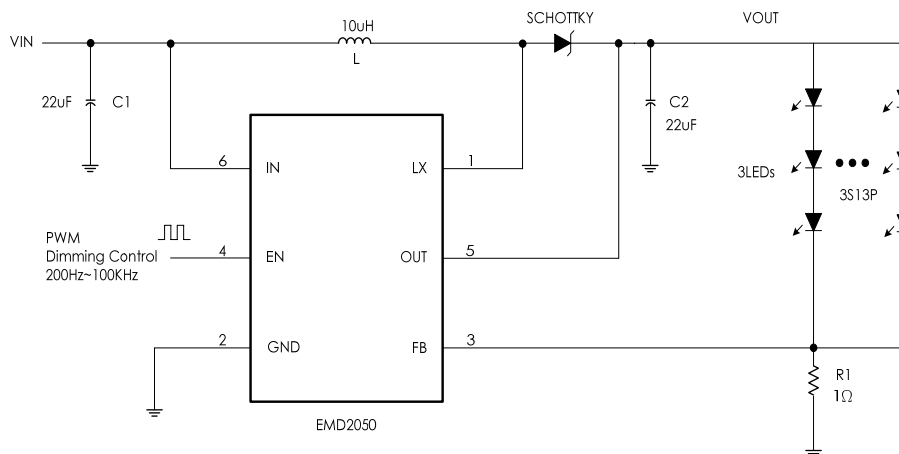
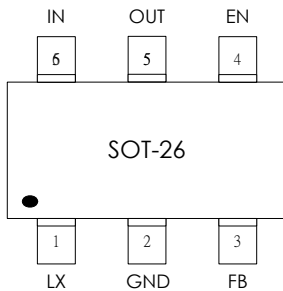

Fig.1

Connection Diagram



Order Information

EMD2050-00VC06NRR	
00	Output voltage
VC06	SOT-26 Package
NRR	RoHS & Halogen free package
	Rating: -40 to 85°C
	Package in Tape & Reel
GRR	RoHS Package (By Request)

Order, Mark & Packing Information

Package	Vout	Product ID	Marking	Packing
SOT-26	Adjustable	EMD2050-00VC06NRR		Tape & Reel 3Kpcs

Pin Functions

Pin Name	SOT-26 Pin #	Function
LX	1	Switch Pin. Connect inductor/diode here.
GND	2	Ground Pin.
FB	3	Feedback Pin. Reference voltage is 0.235V, connect cathode of lowest LED and resistor here.
EN	4	Chip Enable Pin. Connect to 1.2V or higher to enable device, 0.4V or less to disable device.
OUT	5	Over Voltage Protection Pin.
IN	6	Input Voltage Pin.

Absolute Maximum Ratings

Devices are subjected to failure if they stay above absolute maximum ratings

Input Voltage	- 0.3V to 6V	Storage Temperature	-65°C to 150°C
EN, VFB Voltages	- 0.3V to VIN	Junction Temperature	150°C
LX ,OUT Voltage	- 0.3V to 16V	Lead Temperature (Soldering, 10 sec)	260°C
ESD Susceptibility	HBM 2kV MM 200V		
Operating Temperature Range	-40°C to 85°C		

Electrical Characteristics

(V_{CC} = 3.7V, T_A = 25°C, unless otherwise specified.)

PARAMETER	TEST CONDITION	MIN	TYP	MAX	UNIT
Under Voltage Lock Out		1.8		2.4	V
Supply Current	Continuously Switching			1	mA
Quiescent Current	No Switching, VFB = 1V	47	55	70	μA
Shutdown Current	VEN < 0.4V			1	μA
Operation Frequency		0.9	1.2	1.5	MHz
Maximum Duty Cycle		93	95		%
Feedback Voltage		0.2115	0.235	0.2585	V
Thermal Shutdown Protection			160		°C
Thermal Shutdown Hysteresis			20		°C
Ron	I _{sw} = 200mA		0.5	0.8	ohm
Current Limit			1.4		A
Shutdown Voltage Low		0.4			V
Enable Voltage High				1.2	V
EN Leakage Current			1.3		μA
OVP			15		V
OVP Hysteresis		0.2	1	3	V

Typical Performance Characteristics

VIN=3.7V, unless otherwise specified

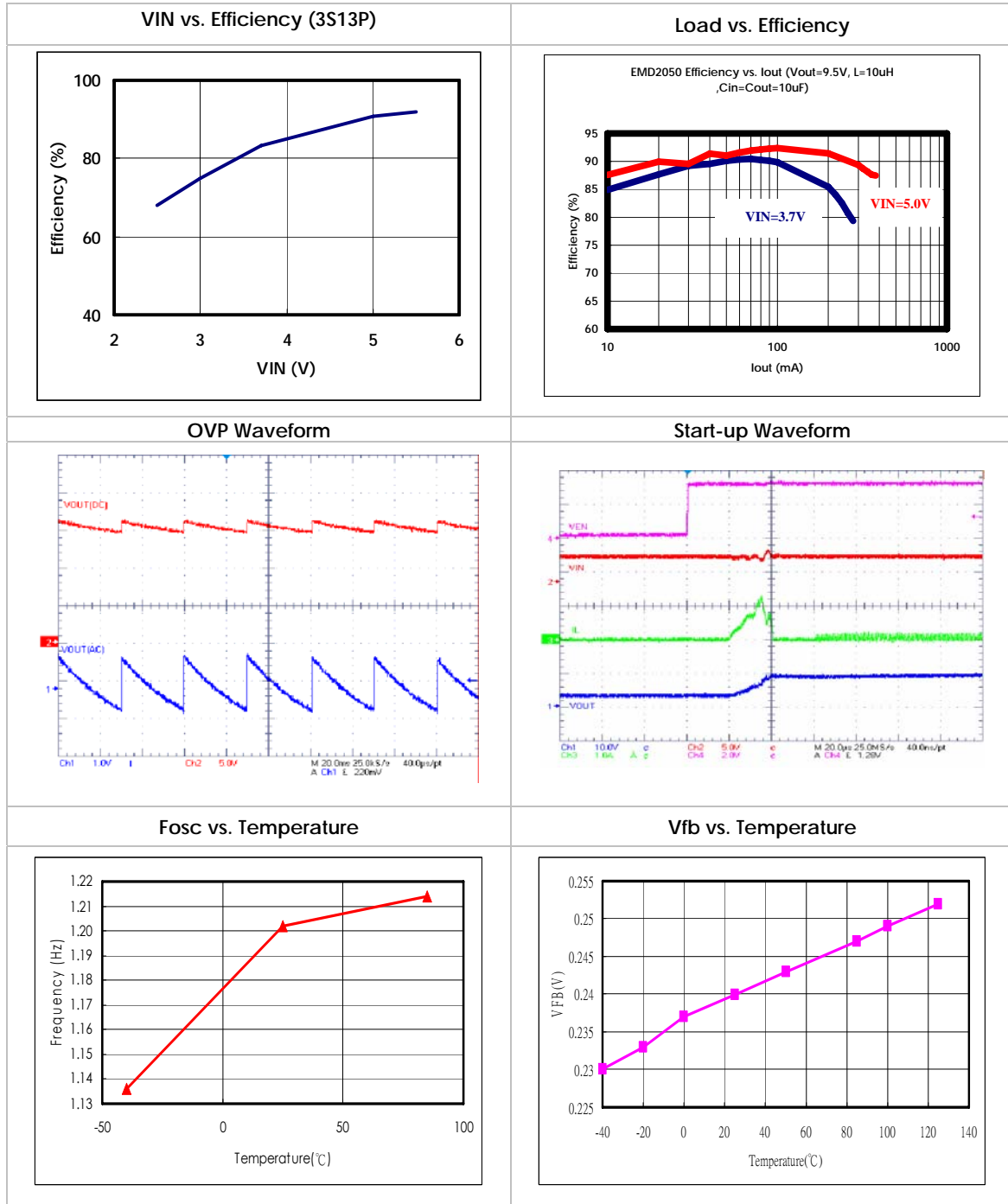

Typical Performance Characteristics

VIN=3.7V, unless otherwise specified

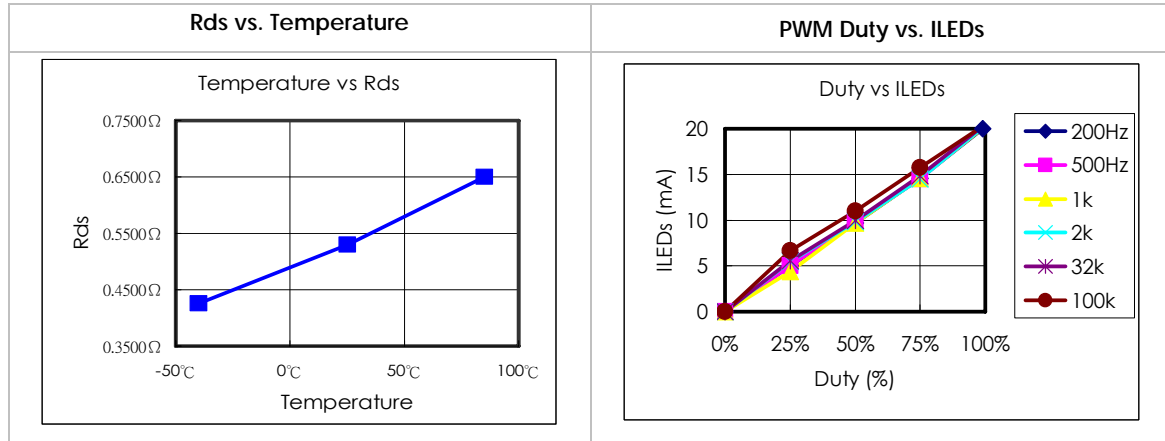

Application Information

Detailed Description

The EMD2050 is a constant frequency current-mode boost converter which can driver WLEDs 3S1P ~ 3S18P. The device provides the same output current through each WLED that get even illumination. The fast operation frequency allows for small inductor and input/output capacitors.

During normal operation, the internal oscillators send a pulse signal to set latch and turn on internal MOSFET each duty circle. A current sense voltage sums MOSFET current and slope signal connected to the negative terminal of the PWM comparator. When this signal voltage exceeds output voltage of error amplifier, the PWM comparator will send a signal to reset latch and turn off internal MOSFET. The output voltage of error amplifier is magnified from the difference between reference voltage and feedback voltage. If reference voltage is higher than feedback voltage, more current is delivered to the output, the other way, less current is delivered.

UVLO

The EMD2050 provides under voltage lock out protection. When VIN is down close to UVLO threshold, the UVLO block will send a signal to turn off power MOSFET. The device stops to supply current to output. The 100mV hysteresis prevents supply transients from causing a restart. Once the VIN exceed UVLO threshold, the device unlocks latch and turn power MOSFET.

Enable / Disable

The EMD2050 enter shutdown mode when EN pin voltage is less 0.4V. When in shutdown mode, all internal circuits of the EMD2050 are turn off and quiescent current is reduced to 1uA. When driver EN pin voltage is higher than 1.2V, start-up begins.

EN pin can be used for dimming control, the PWM frequency range is from 100Hz to 100kHz. The average LED current is proportional to the PWM duty cycle, while 0% duty cycle triggers zero WLEDs current and 100% duty cycle triggers full WLEDs current.

OVP

When WLEDs are open, the boost control loop just like open loop operation, it may causes over voltage damage on LX pin. In order to prevent this damage, the EMD2050 provides OVP function to provide it. The protection threshold is set at 15V.

OTP

The internal thermal sensor turn off power MOSFET when junction temperature is exceeded 160°C, the OTP is designed with a 20°C hysteresis.

LED Current Setting

Referring to Figure 1 of the typical application, adjusting the output current changes the brightness of WLEDs, the EMD2050 regulates output current by sense resistor (R1). The output current is given by:

$$\text{LED current} = 0.235\text{V} / R1$$

Cin and Cout Selection

It is recommended to use the X5R or X7R which have best temperature and voltage characteristics of all the ceramics for a give value and size. A minimum input capacitance of 1μF is required for the EMD2050, The capacitor value may be increased without limit. The typical output capacitor value is 1μF, Higher capacitance can be used to reduce voltage ripple.

Inductor Selection

The inductor values range from 4.7μH to 22μH. The typical inductor value is 10μH. The low DCR inductor is preferred. In addition, the limit saturation current of inductor must exceed current limit of the EMD2050.

Diode Selection

Referring to Figure 1 of the typical application, the EMD2050 is high switching control devise which demands a high speed rectification diode for optimum efficiency. The schottky diode is preferred, for high efficiency, schottky diode provide fast recovery time and low forward voltage that reduce power loss. The recover breakdown voltage of schottky diode must exceed output voltage.

Application Circuit

- Application circuit for 3S1P

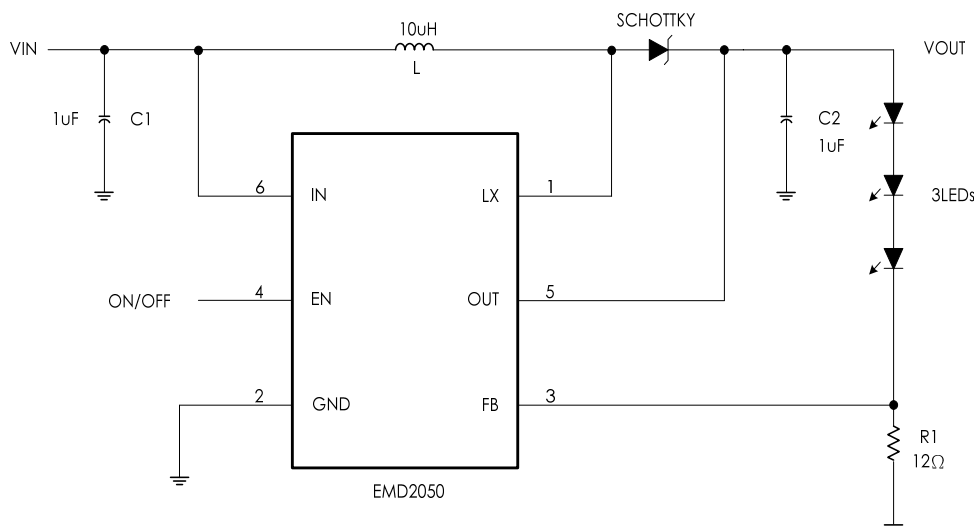

Fig.3

- Application circuit for 3S1P with dimming control

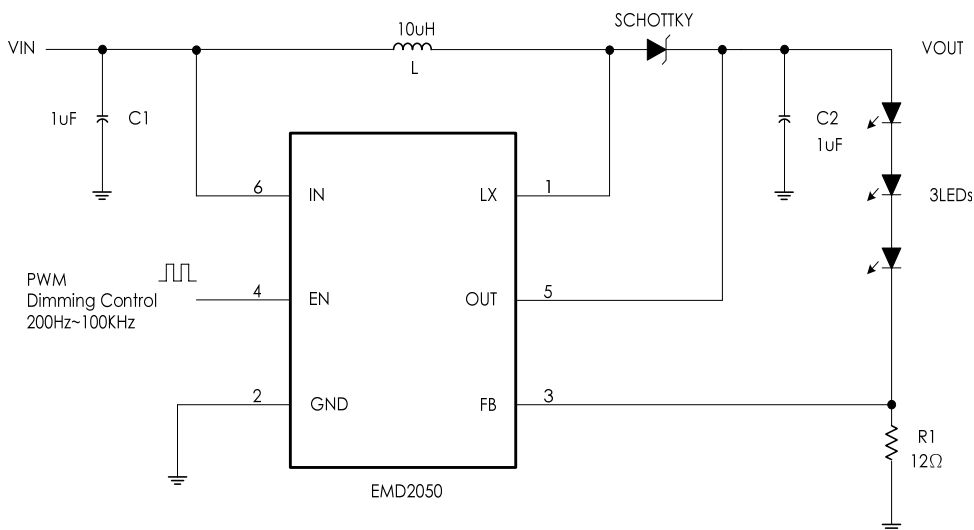

Fig.4

- Application circuit for 3S18P (for VIN=5.0V application)

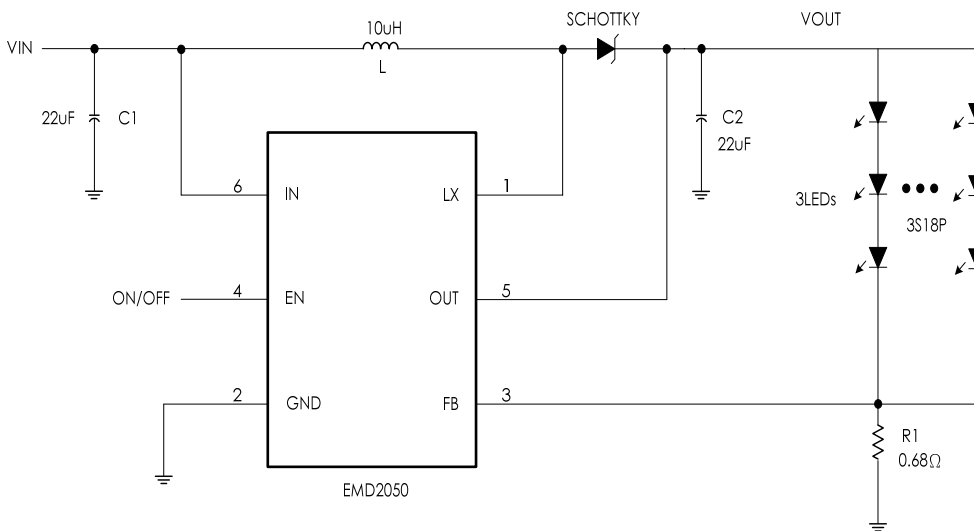
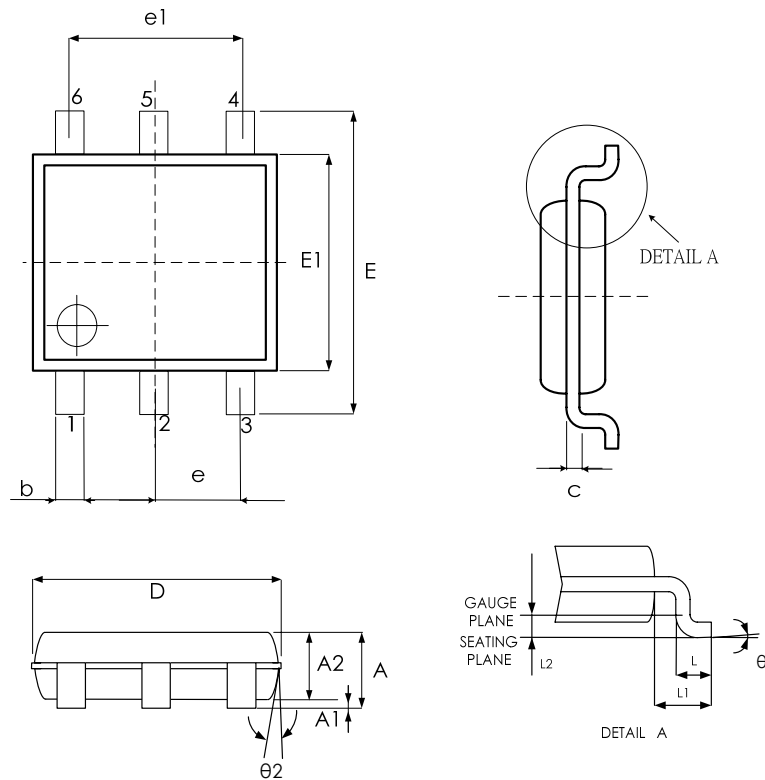

Fig.5

Package Outline SOT-26



SYMBPLS	MIN.	NOM.	MAX.
A	—	—	1.45
A1	—	—	0.15
A2	0.90	1.15	1.30
b	0.30	—	0.50
c	0.08	—	0.22
D	2.90 BSC.		
E	2.80 BSC.		
E1	1.60 BSC.		
e	0.95 BSC		
e1	1.90 BSC		
L	0.30	0.45	0.60
L1	0.60 REF		
L2	0.25 REF		
θ°	0	4	8
$\theta 2^\circ$	5	10	15

Revision History

Revision	Date	Description
0.1	2009.05.08	Original
1.0	2009.10.30	Removed the letters of "Preliminary"

Important Notice

All rights reserved.

No part of this document may be reproduced or duplicated in any form or by any means without the prior permission of ESMT.

The contents contained in this document are believed to be accurate at the time of publication. ESMT assumes no responsibility for any error in this document, and reserves the right to change the products or specification in this document without notice.

The information contained herein is presented only as a guide or examples for the application of our products. No responsibility is assumed by ESMT for any infringement of patents, copyrights, or other intellectual property rights of third parties which may result from its use. No license, either express, implied or otherwise, is granted under any patents, copyrights or other intellectual property rights of ESMT or others.

Any semiconductor devices may have inherently a certain rate of failure. To minimize risks associated with customer's application, adequate design and operating safeguards against injury, damage, or loss from such failure, should be provided by the customer when making application designs.

ESMT's products are not authorized for use in critical applications such as, but not limited to, life support devices or system, where failure or abnormal operation may directly affect human lives or cause physical injury or property damage. If products described here are to be used for such kinds of application, purchaser must do its own quality assurance testing appropriate to such applications.