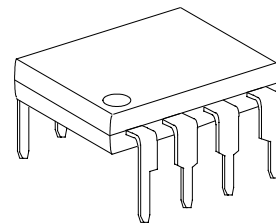

BURST MODE CONTROL IC**GENERAL DESCRIPTION**

The **FP5132B** is a burst mode signal control IC for backlight inverter applications field. The **FP5132B** includes a low frequency open collector output stage for PWM control IC, negative dimming signal input comparing with oscillator, a shutdown input for monitor the lamp terminal abnormal feedback signal, an output 5.0V precision reference supply.

FEATURES

- Wide supply voltage operating range: 6.5 to 30V
- Dimming input control
- Fixed Reference Voltage: 5.0V
- Low oscillator frequency: 50Hz ~ 1KHz
- Shutdown detection input
- Open collector output
- Package: SOP8/PDIP8

**DIP8****TYPICAL APPLICATION**

- PDA backlight inverter
- TFT-LCD backlight inverter
- Notebook backlight inverter

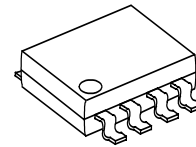
**SOP8**

FUNCTIONAL BLOCK DIAGRAM

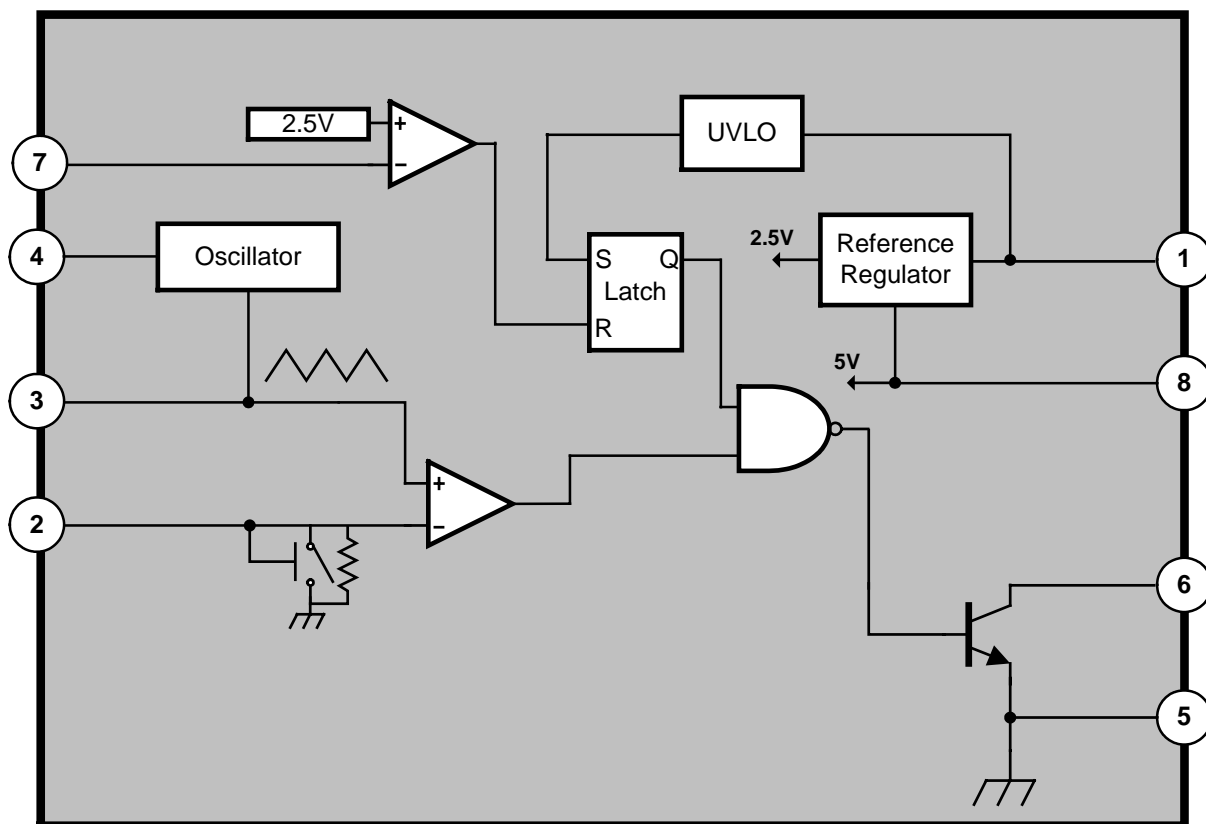

MARK VIEW

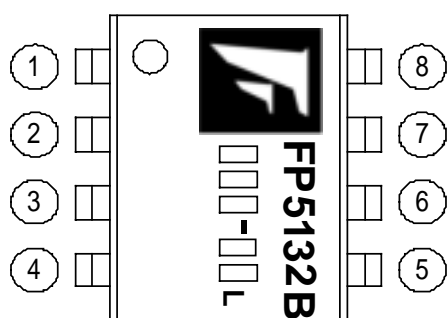

PIN

DESCRIPTION

Name	No.	Status	Description
VCC	1	P	IC power supply
DIM-	2	I	Negative dimming input
CT	3	I	Connect a capacitor for oscillator
RT	4	I	Connect a resistor for oscillator
GND	5	P	IC ground
OUT	6	O	Low frequency O.C. output
SHDN	7	I	Shutdown detection input
VREF	8	O	5V reference voltage output

ORDER INFORMATION

Part Number	Operating Temperature	Package	Description
FP5132BD-LF	-20°C ~ +85°C	SOP8	Tube
FP5132BDR-LF	-20°C ~ +85°C	SOP8	Tape & Reel
FP5132BP-LF	-20°C ~ +85°C	PDIP8	Tube

IC DATE CODE DISTINGUISH

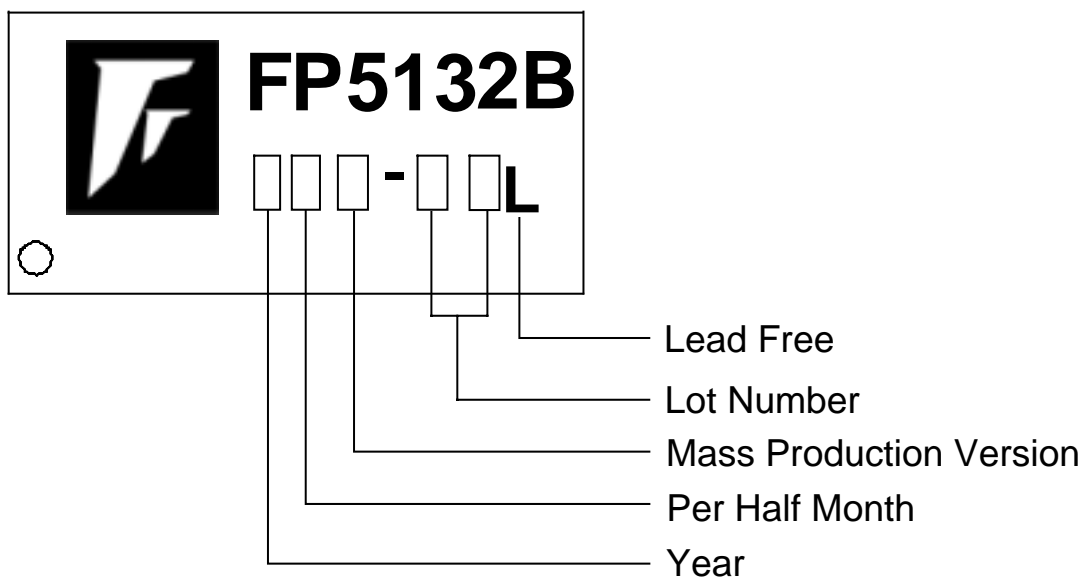

FOR EXAMPLE:

January A (Front Half Month), B (Last Half Month)
 February C, D
 March E, F -----And so on.

Lot Number is the last two number of wafer lot.

For Example:

A3311C62L
 ↳ Lot Number

ABSOLUTE MAXIMUM RATINGS

Supply Voltage (Vcc) -----	+30V
Collector Output Voltage (Vo) -----	+30V
Collector Output Current (Io) -----	+5mA
Maximum Junction Temperature (T _j) -----	+150
Thermal Resistance Junction to Ambient (SOP package)-----	175 /W
(PDIP package)-----	100 /W
Power Dissipation (SOP8 package)	
Ta=25 -----	650mW
Ta=70 -----	550mW
Operating Temperature Range -----	-20 85
Storage Temperature Range -----	-65 150
SOP8 Lead Temperature (soldering, 10 sec) -----	+260
PDIP8 Lead Temperature (soldering, 20 sec) -----	+260

Recommend: IR Reflow

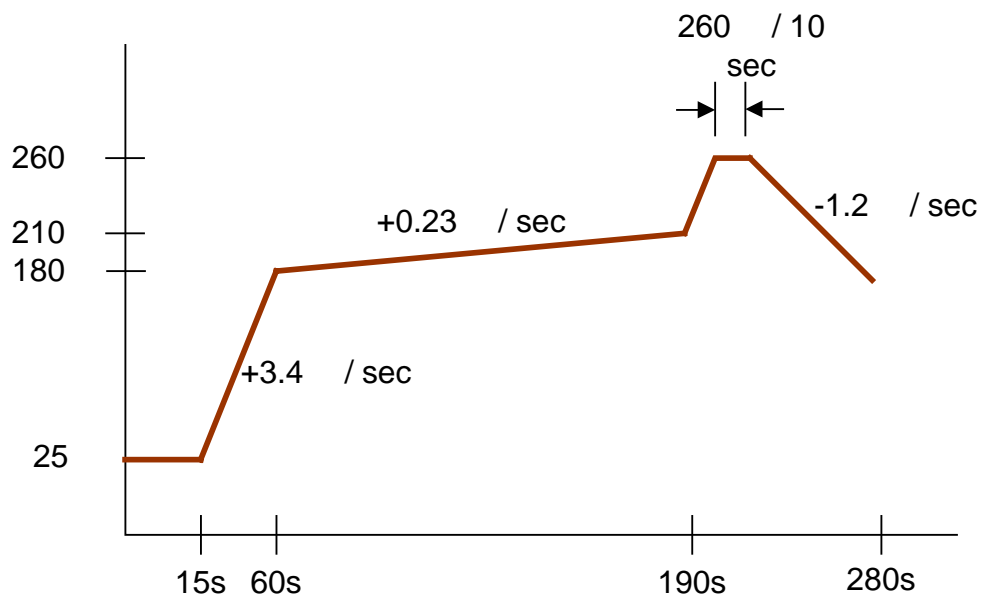

IR Re-flow Soldering Curve

ELECTRICAL CHARACTERISTICS

Electrical characteristics over recommended operating temperature range , VCC = 8V

Reference section

PARAMETER	SYMBOL	TEST CONDITIONS	MIN	TYP	MAX	UNIT
Output voltage (pin 8)	V _{REF}	I _o =1mA	4.90	5.	5.1	V
Output voltage change with Temperature	V _{REF} / T	T _A =-20 to 85		-0.2	±1	%
Input voltage regulation	V _{REF} / VCC	VCC=6.5V 30V	3	5	12.5	mV
Output voltage regulation	V _{REF} / I _o	I _o = 0.1mA to 3 mA	3	5	7.5	mV

Oscillator section

PARAMETER	SYMBOL	TEST CONDITIONS	MIN	TYP	MAX	UNIT
Frequency	f	CT=6.8nF,RT=100K	230	250	270	Hz
Frequency change with voltage	f / V	VCC=6.5V to 30V		1		%
Frequency change with temperature	f / T	T _A =-20 to 85		2		%
Oscillator voltage	V _{RT}	RT=100K	0.53	0.55	0.57	V
Oscillator charge / discharge ratio	Charge/Discharge	CT=6.8nF,RT=100K	0.9	1.05	1.2	-

Output section

PARAMETER	SYMBOL	TEST CONDITIONS	MIN	TYP	MAX	UNIT
Output saturation voltage	V _{SAT}	I _o = 3mA	0.01	0.1	0.15	V

Dimming input section

PARAMETER	SYMBOL	TEST CONDITIONS	MIN	TYP	MAX	UNIT
Dimming input (PWM Active High)	Dim-	Zero Duty Cycle	0.97	1.0	1.03	V
		Maximum Duty Cycle	2.9	3.0	3.1	V

Shutdown section

PARAMETER	SYMBOL	TEST CONDITIONS	MIN	TYP	MAX	UNIT
Shutdown Threshold voltage	V _{SHDN}	IC operation	2.4	2.5	2.6	V

Total device section

PARAMETER	SYMBOL	TEST CONDITIONS	MIN	TYP	MAX	UNIT
Average supply current	I _{ave}		1.0	1.5	2.0	mA

†All typical values are at T_A = 25 .

TYPICAL CHARACTERISTICS

Frequency VS Temperature

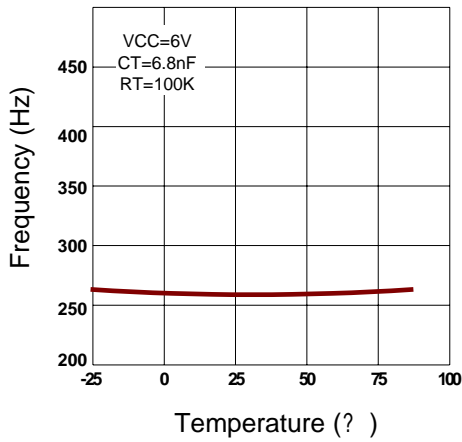

Figure 1

CT-Capacitance VS Frequency

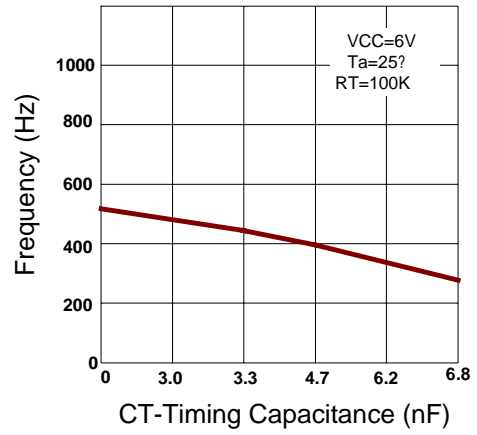

Figure 2

Output Saturation Voltage VS Output (sink) Current

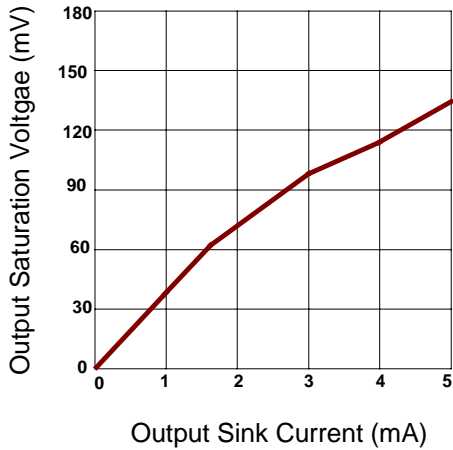

Figure 3

Supply Voltage VS Supply Current

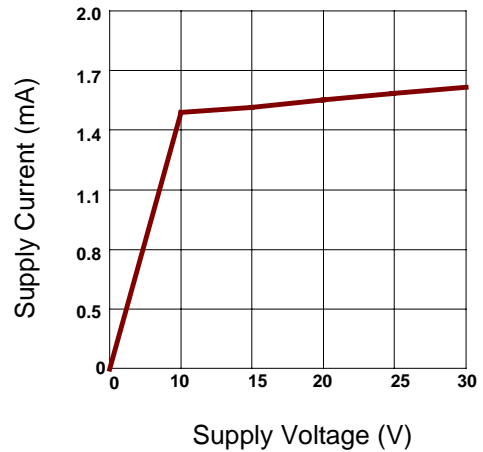

Figure 4

CT-Charge Current VS Temperature

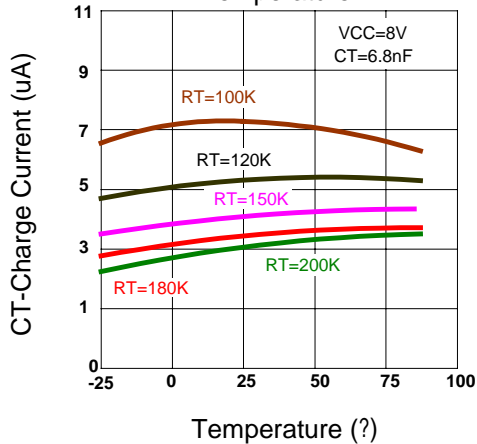

Figure 5

CT-Discharge Current VS Temperature

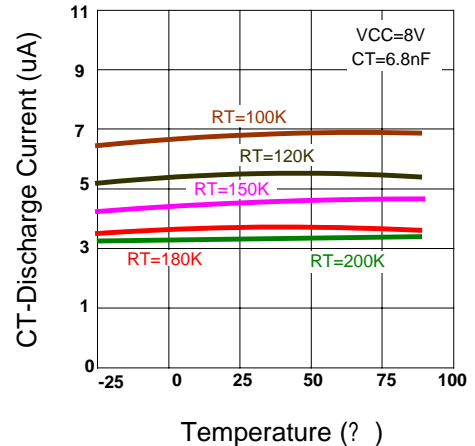
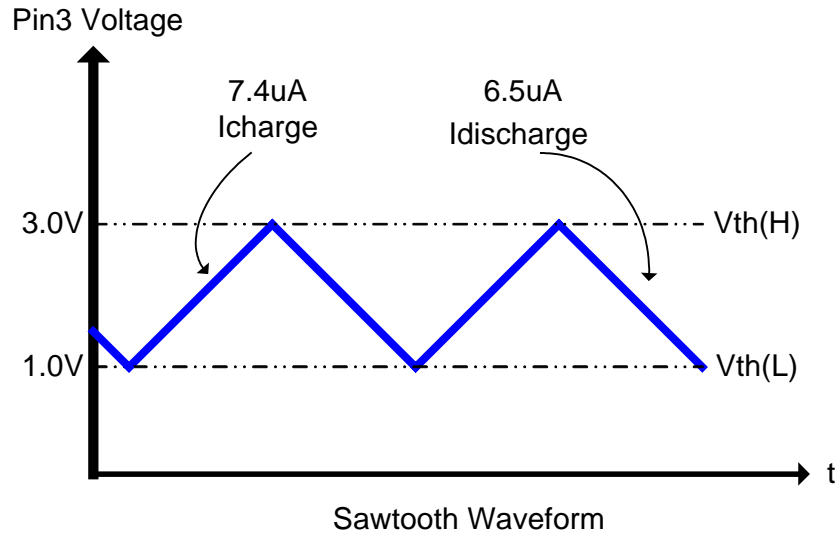

Figure 6

DETAILED DESCRIPTION

Oscillator

The oscillation frequency is a sawtooth waveform, the **FP5132B** charge current and discharge current is determined by an external resistor that is connected to **FP5132B** pin4, the frequency compares with the threshold voltage, using the below formula for the oscillation frequency calculation.



FP5132B oscillation waveform

The oscillation frequency formula:

$$I_{charge} = 1.24 * \frac{V_{RT}}{RT} ; I_{discharge} = 0.95 * I_{charge} \text{ --- Equation 1}$$

$$f = \frac{I_{charge} * I_{discharge}}{CT * (V_{th}(H) - V_{th}(L)) * (I_{charge} + I_{discharge})} \text{ --- Equation 2}$$

For example:

RT=100K , CT=6.8nF and VRT is 0.565V, the oscillation frequency is:

From equation 1, the charge and discharge current are:

I_{charge}=7.006 μA, I_{discharge}=6.655 μA then using equation 2:

$$f = \frac{7.006 \mu A * 6.655 \mu A}{6.8 nF * (3.0V - 1.0V) * (7.006 \mu A + 6.655 \mu A)} = 250.955 Hz$$

Voltage reference

A 5.0V reference regulator supplies **FP5132B** internal circuits and uses the resistive dividers to provide a wide range dimming control range, the **FP5132B** typical dimming voltage range is between 1.0V and 3.0V, If the external input range is from 0.2V to 4.9V, it is calculated by the principle of superposition, the application circuits is shown as below:

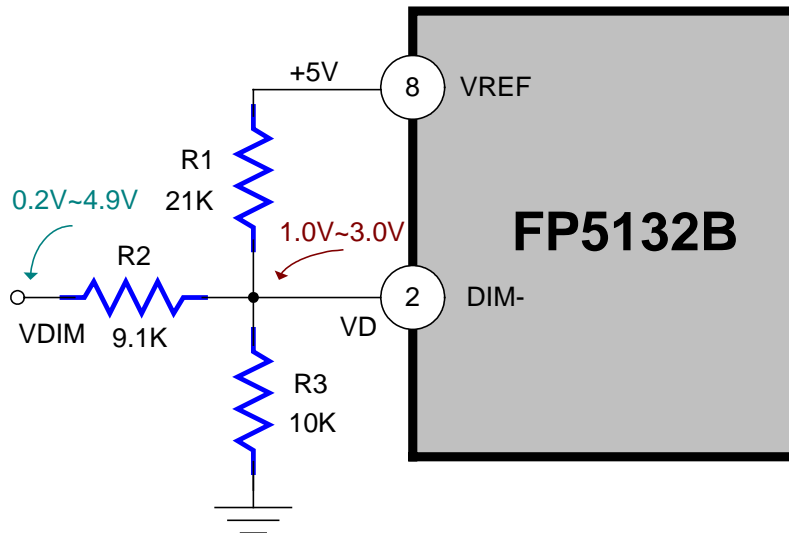

Superposition principle for wide range dimming adjust function

The wide dimming adjust voltage VDM of superposition principle equation is:

$$VD = \frac{R1 // R3}{R2 + R1 // R3} VDIM + \frac{R2 // R3}{R1 + R2 // R3} VREF \quad \text{-- Equation 3}$$

For example:

The Conditions are:

VDIM=0.2V, VD=1.0V and VDIM=4.9V, VD=3.0V

choice R3=10K , and using equation 3 to solve the R2=9.2K (use 9.1K) and the R1=21.39K (use 21K)

Dimming and open collector PWM output

The dimming input (DIM-) of **FP5132B** compares with oscillation frequency, and the PWM output duty cycle change of **FP5132B** depends on the dimming input voltage level that shows below:

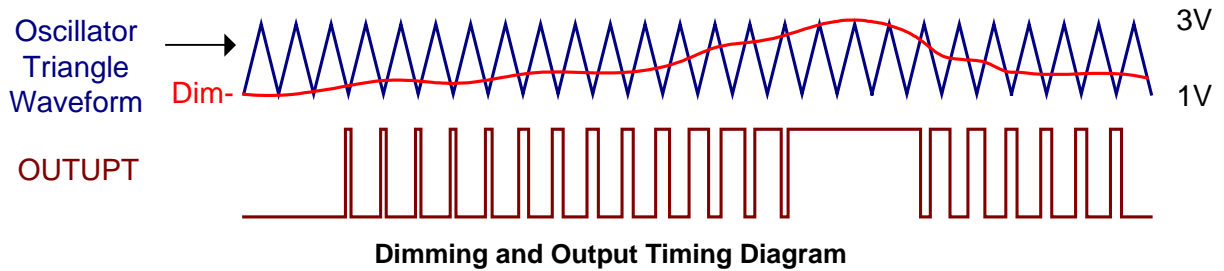

Shutdown

The shutdown function of **FP5132B** is turn-off PWM output when the shutdown voltage of PIN7 is under a 2.5V threshold voltage, and if PIN7 voltage is higher than 2.5V again, there is a PWM signal output generation. The basic application function is using for CCFL open or short, the protection signal could pull down PIN7 voltage under 2.5V, and the PWM signal of **FP5132B** output would turn off (internal pull low).

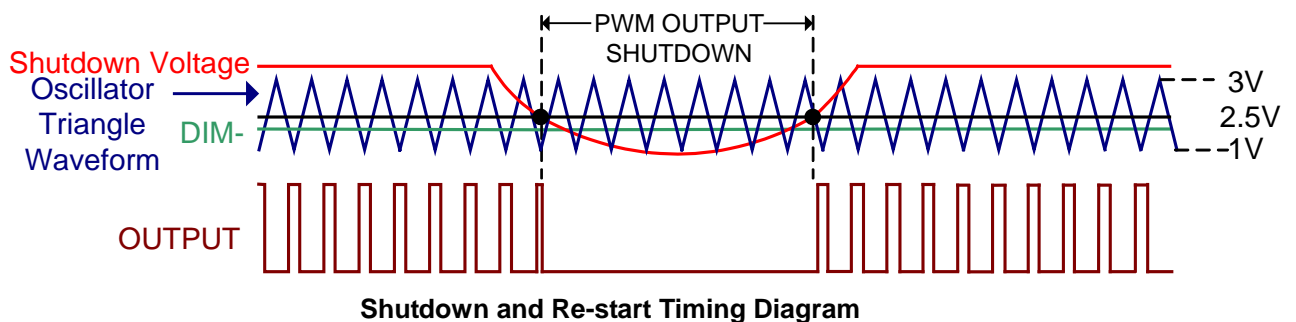

MEASUREMENT WAVEFORM

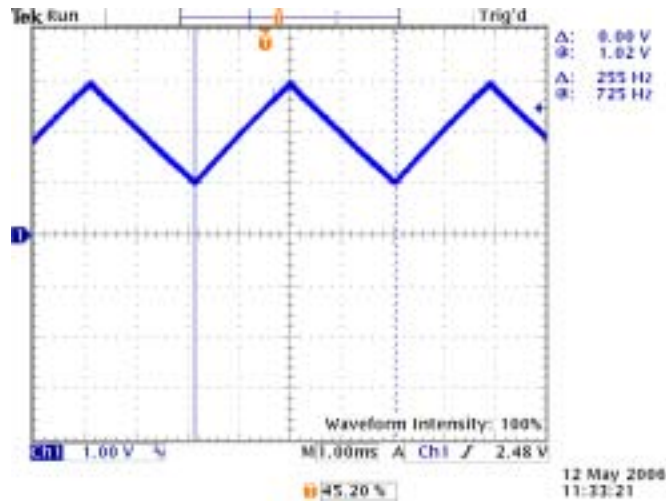

FP5132B Oscillation Frequency Waveform

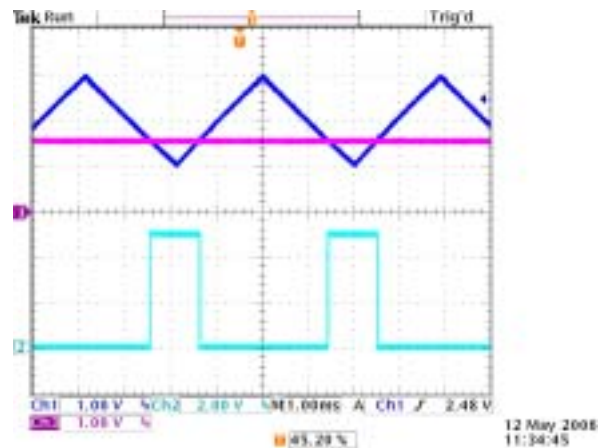
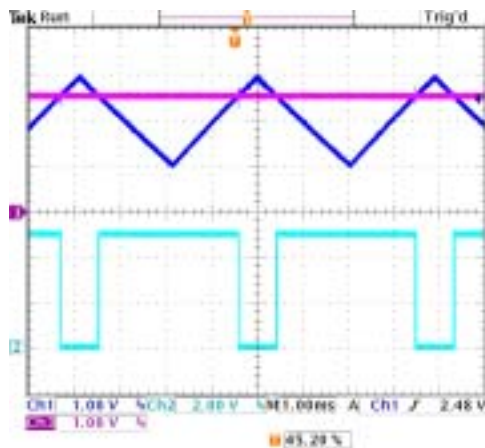

FP5132B Dimming Voltage and PWM Output Waveform

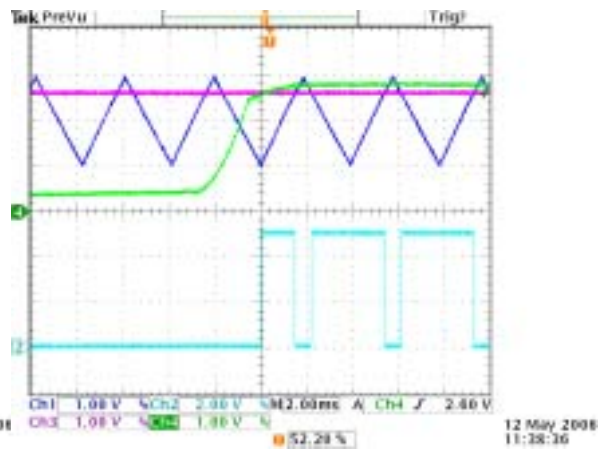
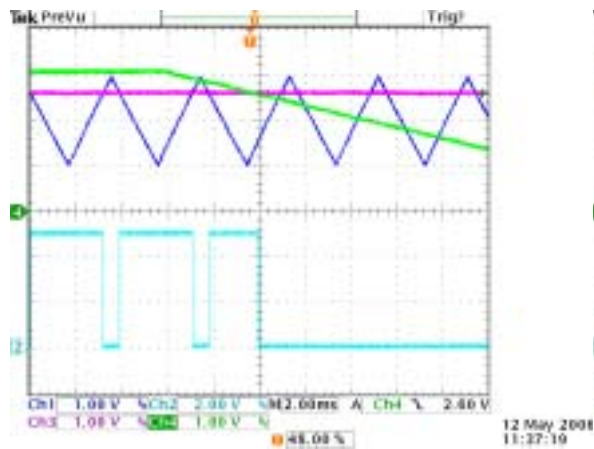

FP5132B PWM Output Shutdown Function Waveform (2.5V Threshold Voltage)

APPLICATION CIRCUITS

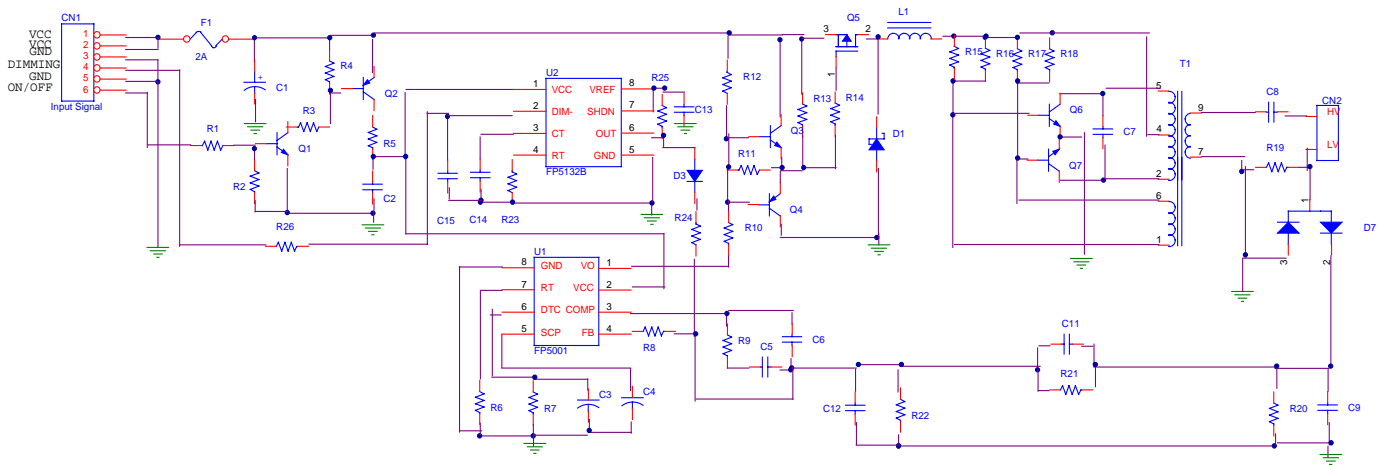

2-lamp CCFL Inverter with FP5132B Burst Mode Dimming Control

Note

U2 is **FP5132B**, using for a burst mode 1-lamp Royer CCFL inverter with FP5001, the R23-C14 choose the oscillation frequency, and R26-C15 is a simple DIM signal noise rejection filter, the D3 avoids the CCFL feedback signal when burst PWM signal is low state.

The burst PWM voltage must higher than 1.0V VFB voltage for turn-off FP5001 PWM, the bias voltage depends on **FP5132B** burst PWM voltage level and feedback path impedance.

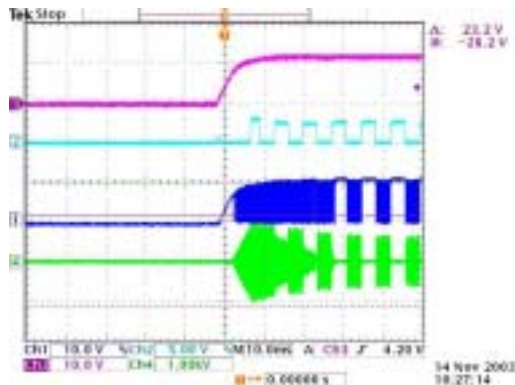

Inverter Power-On

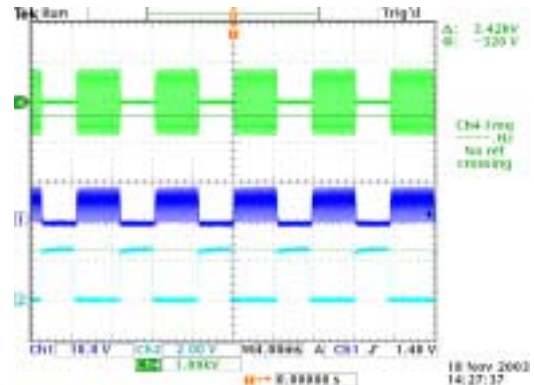

50% Dimming Control

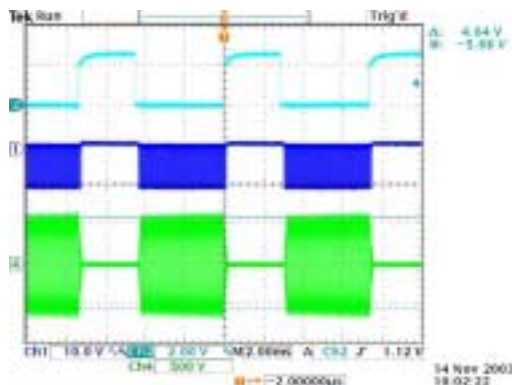

T.B. X2

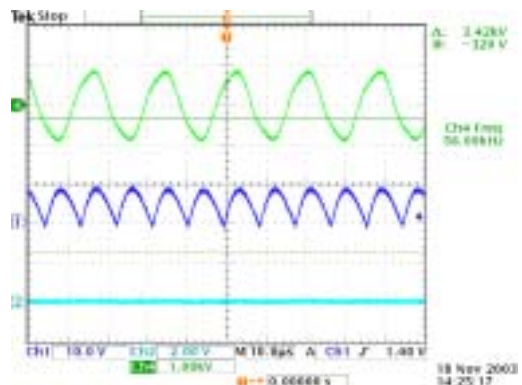

.B. X400 (Full)

PACKAGE OUTLINE

SOP 8

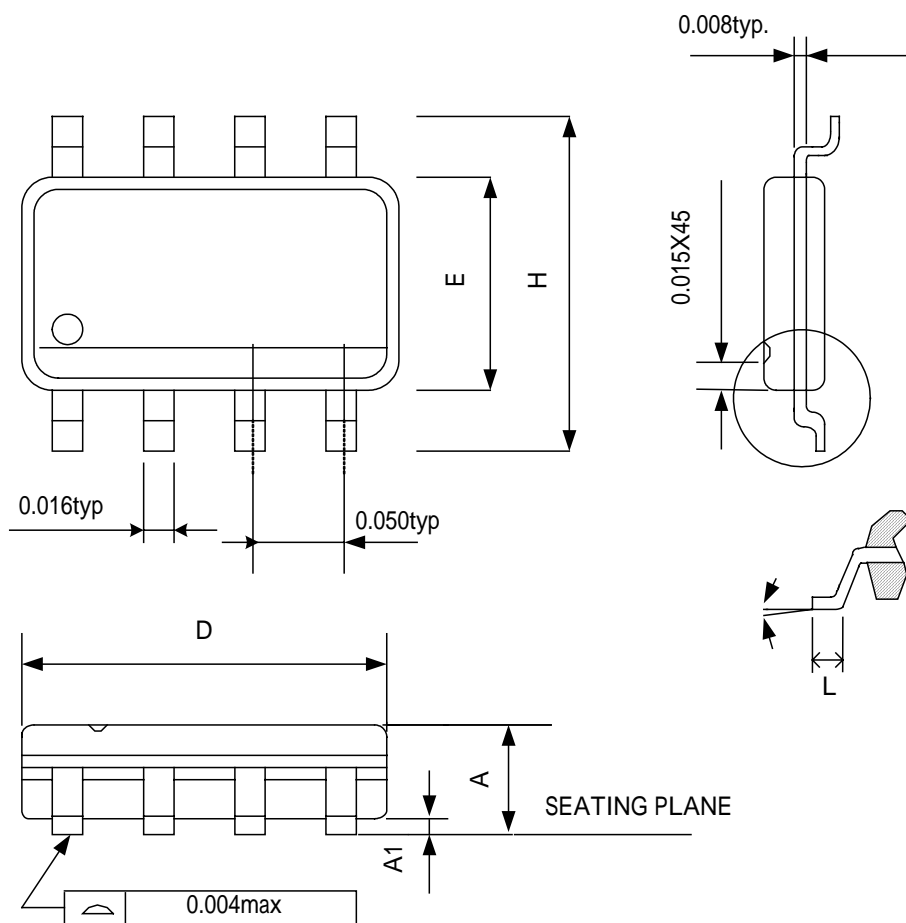

SYMBOLS	MIN	MAX
A	0.053	0.069
A1	0.004	0.010
D	0.189	0.196
E	0.150	0.157
H	0.228	0.244
L	0.016	0.050
°	0	8

UNIT:INCH

NOTE:

1. JEDEC OUTLINE:MS-012 AA
2. DIMENSIONS "D" DOES NOT INCLUDE MOLD FLASH,PROTRUSIONS OR GATE BURRS.MOLD FLASH,PROTRUSIONS AND GATE BURRS SHALL NOT EXCEED .15mm (.06in) PER SIDE
3. DIMENSIONS "E" DOES NOT INCLUDE INTER-LEAD FLASH,OR PROTRUSIONS. INTER-LEAD FLASH AND PROTRUSIONS SHALL NOT EXCEED .25mm (.0.10in) PER SIDE.

PDIP 8

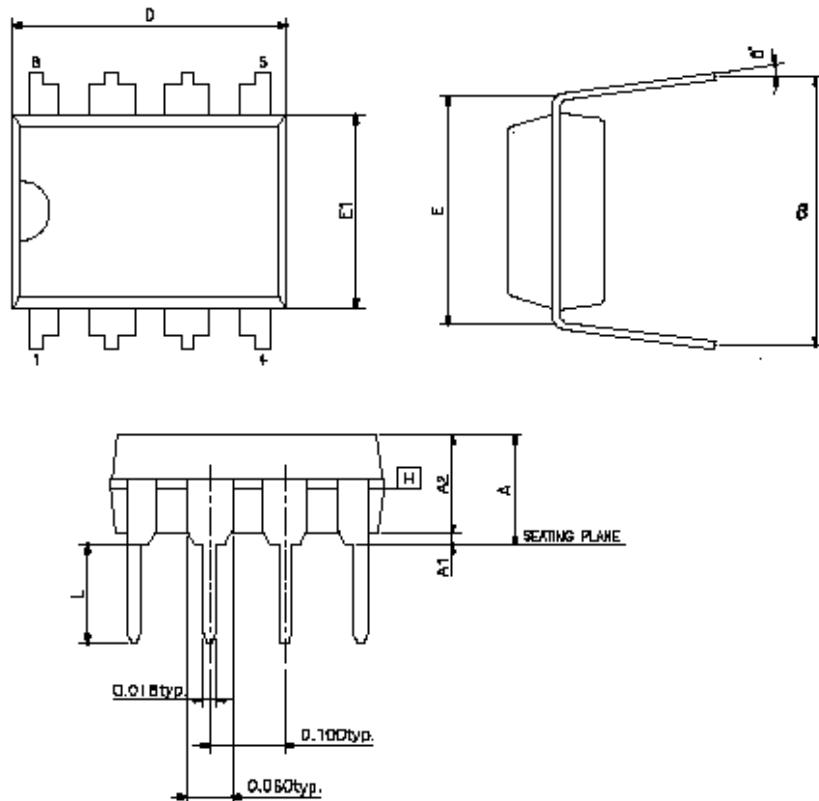

SYMBOLS	MIN	NOR	MAX
A	-	-	0.210
A1	0.015	-	-
A2	0.125	0.130	0.135
D	0.355	0.365	0.400
E	0.300BSC		
E1	0.245	0.250	0.255
L	0.115	0.130	0.150
e	0.335	0.355	0.375
°	0	7	15

UNIT:INCH

Note:

0. JEDEC OUTLINE:MS-001 BA
1. "D""E1" DIMENSIONS DO NOT INCLUDE MOLD FLASH OR PROTRUSIONS SHALL NOT EXCEED .010 INCH
2. eB IS MEASURED AT THE LEAD TIPS WITH THE LEADS UNCONSTRAINED
3. POINTED OR ROUNDED LEAD TIPS ARE PREFERRED TO EASE INSERTION
4. DISTANCE BETWEEN LEADS INCLUDING DAM BAR PROTRUSIONS TO BE .005 INCH MINIMUM
5. DATUM PLANE H COINCIDENT WITH THE BOTTOM OF LEAD, WHERE LEAD EXITS BODY.

PACKING SPECIFICATIONS

BOX DIMENSION

TUBE INSIDE BOX AND CARTON

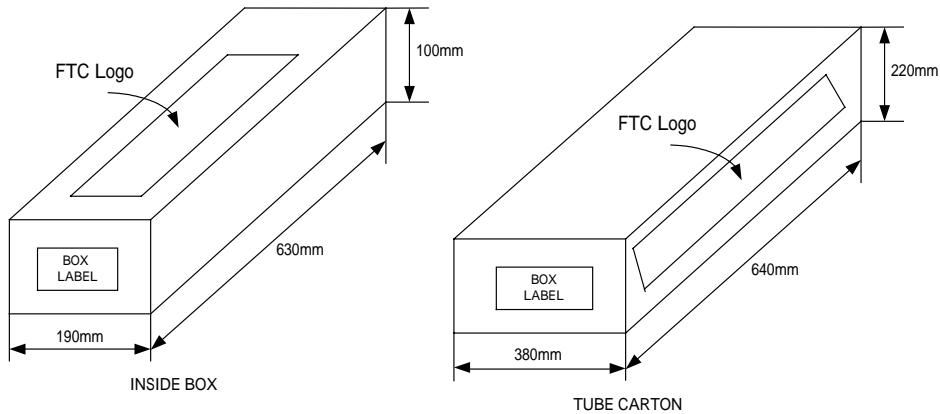

TAPE & REEL INSIDE BOX AND CARTON

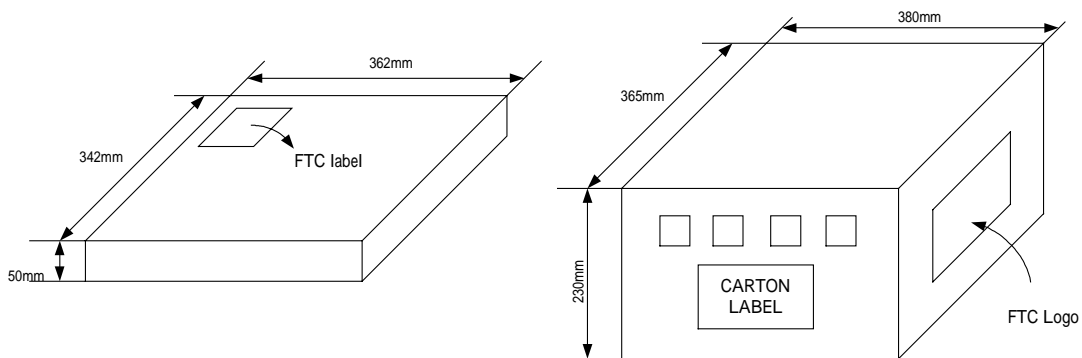

PACKING QUANTITY SPECIFICATIONS

100 EA / TUBE	2500 EA / REEL
100 TUBES / INSIDE BOX	4 INSIDE BOXES / CARTON
4 INSIDE BOXES / CARTON	

LABEL SPECIFICATIONS

TAPPING & REEL

CART

ON

Feeling Technology Corp.	
Product	FP5132BDR-LF
Lot No	A3311C62-L
D/C	6Xx-62L
Q'ty	2,500
無鉛 Lead Free	

Feeling Technology Corp.	
Product Type:	FP5132BDR-LF
Lot No:	A3311C62-L
Date Code:	6Xx-62L
Package Type:	SOP-8L
Marking Type:	Laser
Total Q'ty:	10,000
無鉛 Lead Free	

CARRIER TAPE DIMENSIONS

APPLICATION	W	P	E	F	D	D ₁
SOP8	12.0 ^{+0.3} _{-0.1}	8.0±0.1	1.75±0.1	5.5±0.1	1.55±0.1	1.5 ^{+0.25}

APPLICATION	P ₀	P ₁	A ₀	B ₀	K ₀	t
SOP8	4.0±0.1	2.0±0.1	6.4±0.1	5.20±0.1	2.1±0.10	0.30±0.013

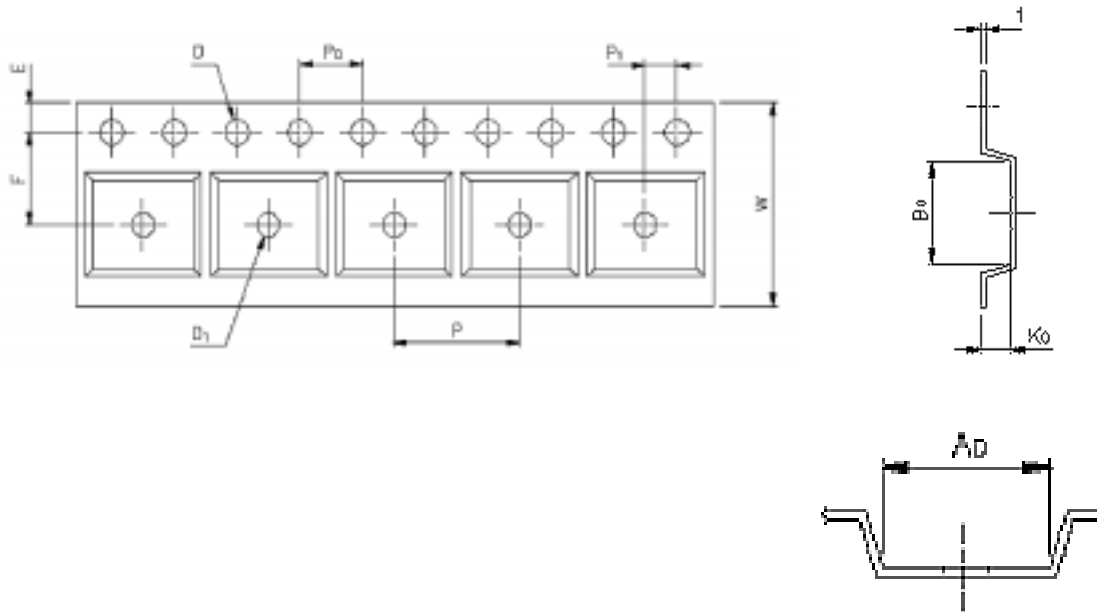

REEL DIMENSIONS

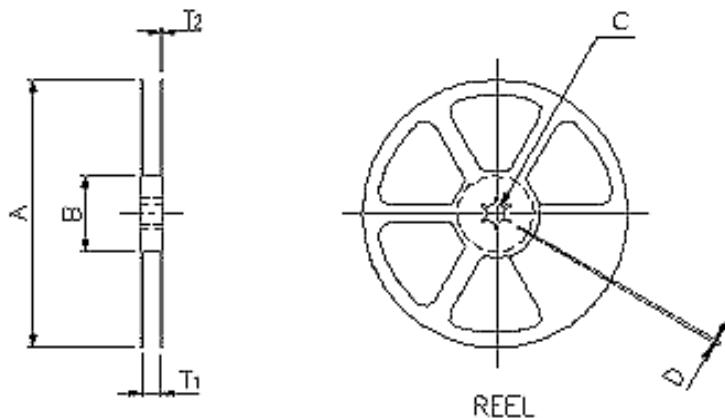

APPLICATION	MATERIAL	A	B	C	D	T ₁	T ₂
SOP8	PLASTIC REEL	330±0.1	62±1.5	12.75±0.15	2±0.6	12.4±0.2	2.0±0.2