

ICE 1QS01

Controller for Quasiresonant
Switch Mode Power Supplies
Supporting Low Power Standby
and Power Factor Correction

Power Management & Supply



Never stop thinking.

ICE1QS01 Revision History: Current Version: 2004- 04-27		
Previous Version: 2003- 11-28		
Page13 (in previous version)	Page 13 (in current version)	Diagram mains undervoltage lockout curent added
Page 16-18 (in previous version)	Page 16-18 (in current version)	Min.- max.- values added, typ. values adapted, according to measuring results.
Page 20 (in previous version)	Page 20 (in current version)	Application circuit changed to new 250 W demo board with PFC current pump.

Edition 2004-04-27

**Published by Infineon Technologies AG,
St.-Martin-Strasse 53,
D-81541 München
© Infineon Technologies AG 2004.
All Rights Reserved.**

Attention please!

The information herein is given to describe certain components and shall not be considered as warranted characteristics.

Terms of delivery and rights to technical change reserved.

We hereby disclaim any and all warranties, including but not limited to warranties of non-infringement, regarding circuits, descriptions and charts stated herein.

Infineon Technologies is an approved CECC manufacturer.

Information

For further information on technology, delivery terms and conditions and prices please contact your nearest Infineon Technologies Office in Germany or our Infineon Technologies Representatives worldwide (see address list).

Warnings

Due to technical requirements components may contain dangerous substances. For information on the types in question please contact your nearest Infineon Technologies Office.

Infineon Technologies Components may only be used in life-support devices or systems with the express written approval of Infineon Technologies, if a failure of such components can reasonably be expected to cause the failure of that life-support device or system, or to affect the safety or effectiveness of that device or system. Life support devices or systems are intended to be implanted in the human body, or to support and/or maintain and sustain and/or protect human life. If they fail, it is reasonable to assume that the health of the user or other persons

Controller for Switch Mode Power Supplies Supporting Low Power Standby and Power Factor Correction (PFC)

Features

- Quasiresonant Operation
- Primary and Secondary Regulation
- Primary Current Simulation
- Standby Input Power < 1 W
- Low Power Consumption
- Very Low Start-up Current
- Soft-Start for noiseless Start-up
- Standby Burst Mode with and without Control Signal for lowered Output Voltages
- Digital Frequency Reduction in small Steps at Decreasing Load
- Over- and Undervoltage Lockout
- Switch Off at Mains Undervoltage
- Mains Voltage Dependent Fold Back Point Correction
- Ringing Suppression Time Controlled from Output Voltage
- Free usable Fault Comparator

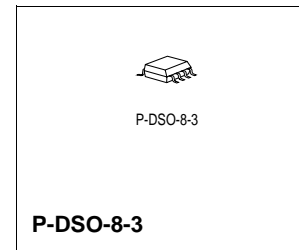
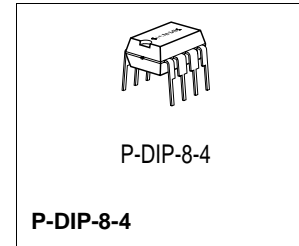

Functional Description

The ICE1QS01 is optimized to control free running flyback converters with and without Power Factor Correction (with PFC Charge Pump).

The switching frequency is reduced in small steps with decreasing load towards a minimum of 20 kHz in standby mode. This function is performed by a digital circuit to avoid any jitter also with periodically pulsed loads. To provide extremely low power consumption at light loads, this device can be switched into Standby Burst Mode. This is also possible without standby control signal (for adapter application).

Additionally, the start up current is very low. To avoid switching stresses of the power devices, the power transistor is always switched on at minimum voltage. The device has several protection functions: V_{CC} over- and undervoltage, mains undervoltage and current limiting. Regulation can be done by using the internal error amplifier or an opto coupler feedback. The output driver is ideally suited for driving a power MOSFET.

The ICE1QS01 is suited for TV-sets, DVD- sets, SAT- receivers and other consumer applications in the power range from 0 to app. 300 W.

Type	Ordering Code	Package
ICE1QS01	Q67040-S4558	P-DIP-8
ICE1QS01G	Q67040-S4559	P-DSO-8

Version 1.4		3		27 Apr 2004
-------------	--	---	--	-------------

Block Diagram

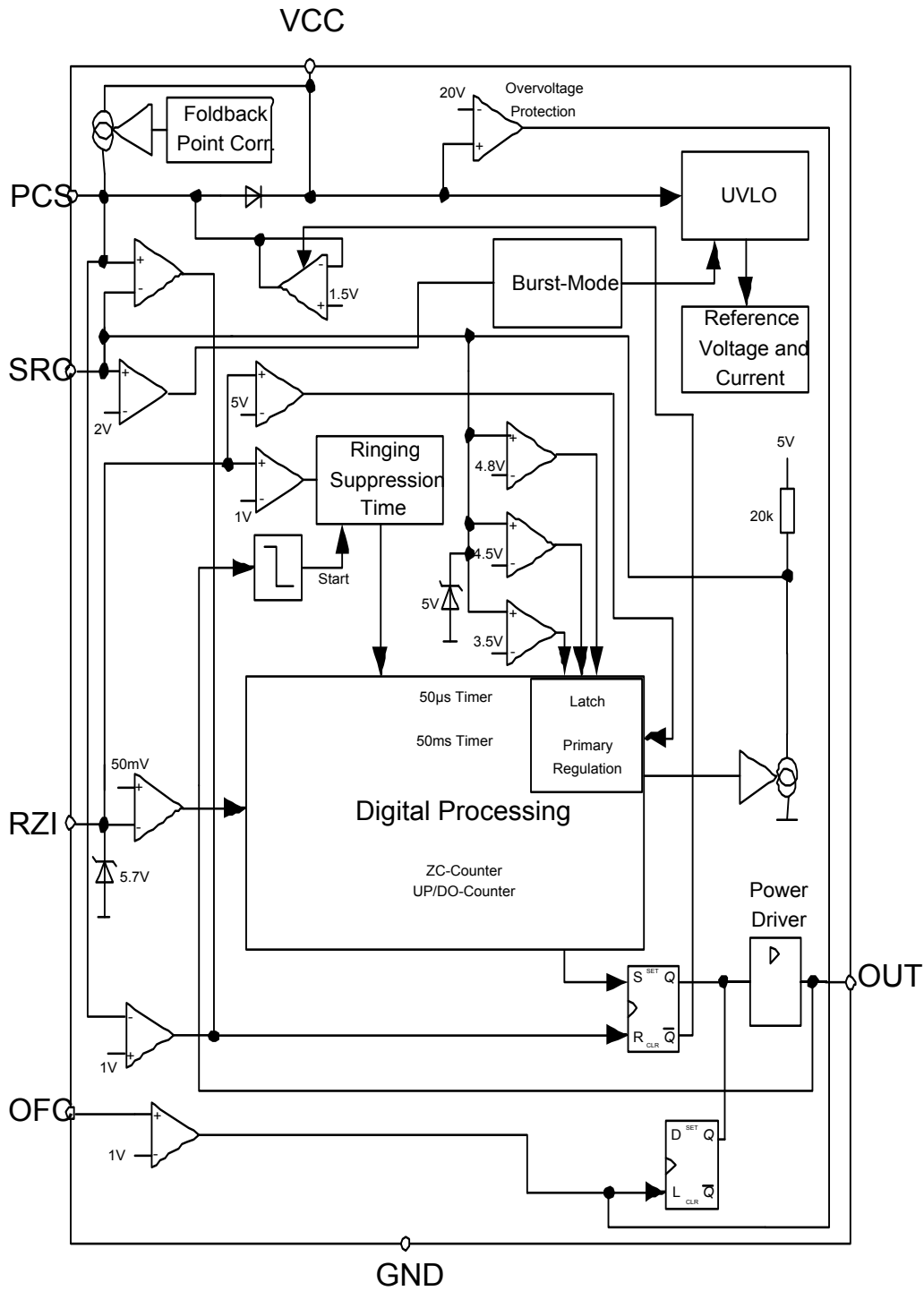

Pinning

Pin	Symbol	Function
1	N.C.	
2	PCS	Primary Current Simulation
3	RZI	Regulation and Zero Crossing Input
4	SRC	Soft-Start and Regulation Capacitor
5	OFC	Overvoltage Fault Comparator
6	GND	Ground
7	OUT	Output
8	VCC	Supply Voltage

Pin Configuration (top view)

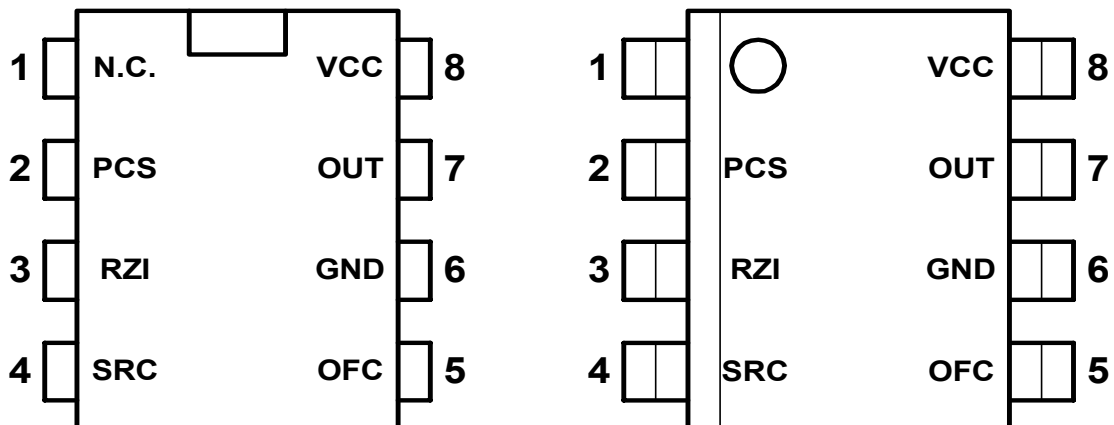

Functional Description

Start up

An internal start up diode is connected between pin PCS and pin V_{CC} . Start up current is provided via this diode if V_{PCS} is higher than $V_{CC} + V_{BE}$ (V_{BE} = Base-Emitter-Voltage).

During start up the internal reference of the IC is shut off and current consumption is about 60 μ A. There is only the start up circuitry working which determines the V_{CCon} threshold. Gate driver OUT is switched to low. An active shut down circuitry ensures that OUT is held below the MOS gate threshold when the IC is in start up mode.

Block Diagram: Start Up

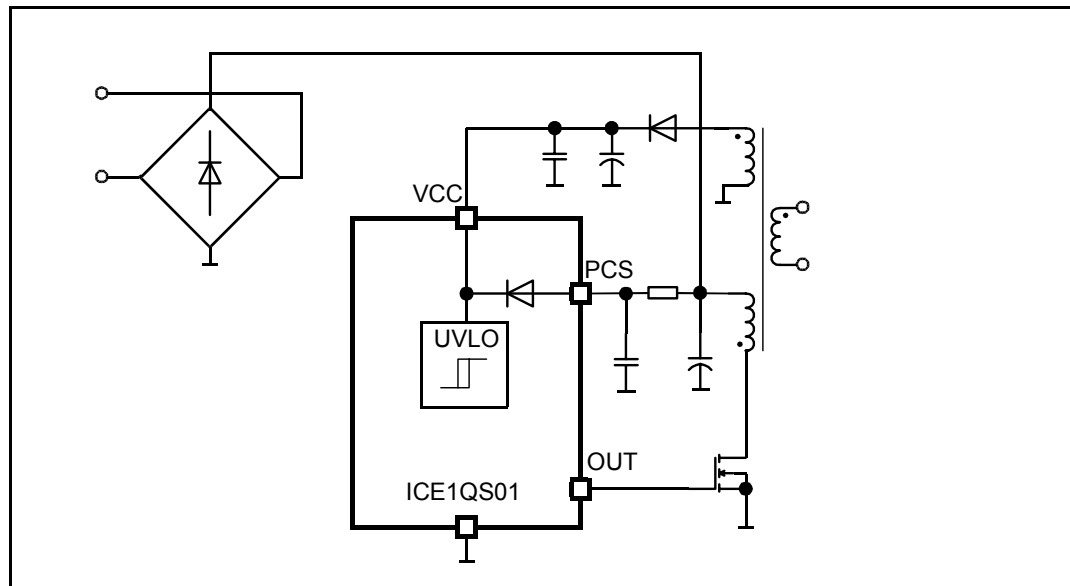

Soft start

The internal reference of the IC is switched on when V_{CC} exceeds the V_{CCon} threshold. The IC begins to work with soft start mode. Soft start is realized with an internal soft start resistor, an internal current sink, a current source and the external feedback capacitor connected at pin SRC. The internal resistor is connected between the internal voltage reference and pin SRC. The current sink is connected between pin SRC and GND. The value of the current is set with a timer. Immediately after the IC is switched on the capacitor C_{SRC} is charged with a current source up to 2.5V. This current source is switched off 12 μ sec after beginning of soft start. The current value of the current sink is set with a timer. Every three msec the current of the current sink is reduced and so V_{SRC} can increase stepwise. The soft start is finished 24 msec after the IC is switched on. At the end of the soft start the current sink is switched off.

Figure: Soft Start

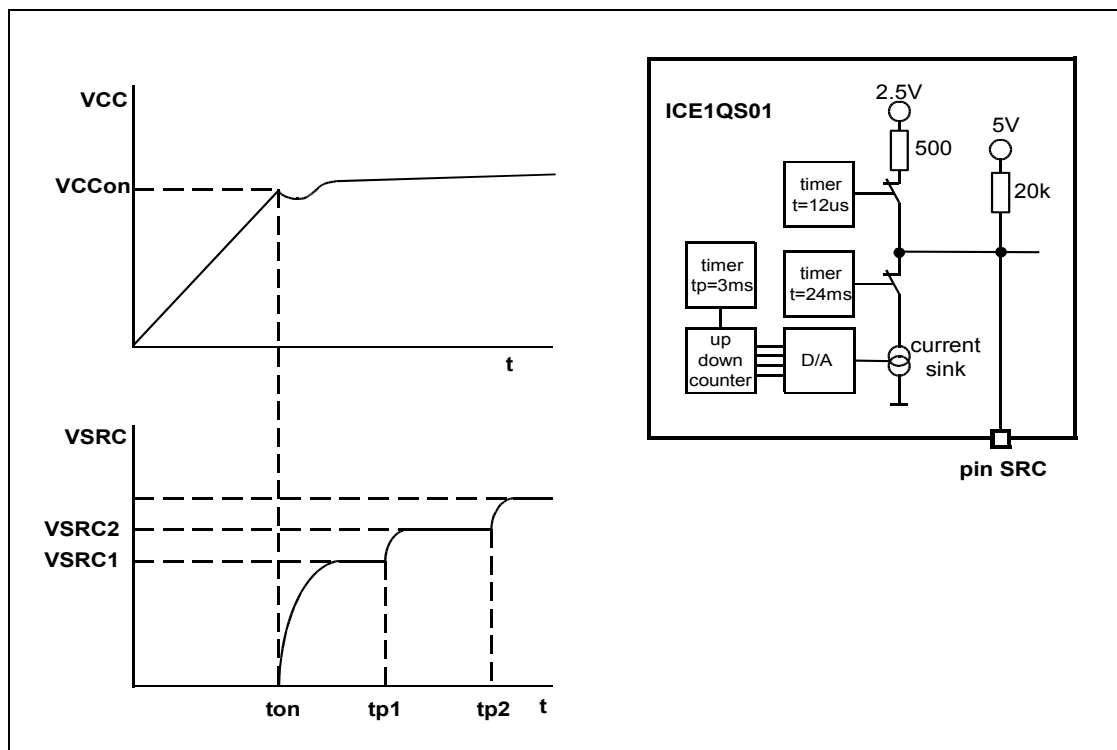

PCS (primary current simulation)

A voltage proportional to the current of the power transistor is generated at Pin PCS by the RC-combination R2, C2. The voltage at Pin PCS is forced to 1.5V when the power transistor is switched off and during its switch on time C2 is charged by R2 from the rectified mains. The relation of V_{PCS} and

the current in the power transistor ($I_{primary}$) is:

$$V_{PCS} = 1,5V + \frac{L_{primary} \times I_{primary}}{R2 \times C2}$$

$L_{primary}$: Primary inductance of the transformer

The advantage of primary current simulation is the elimination of the leading edge spike, which is generated when the power transistor is switched on.

RZI (zero crossing input and primary regulation)

Zero current counter

Every time when the falling voltage ramp of V_{RZI} crosses the 50 mV threshold a pulse is sent to the zero-current-counter and increases the counter by one. If zero-current-counter and up-down-counter are equal the gate drive OUT is switched to high. Up-down counter is influenced via SRC voltage as described below. If V_{RZI} is greater than 50 mV gate drive OUT is always switched low.

Figure: Zero Crossing Switching Behaviour

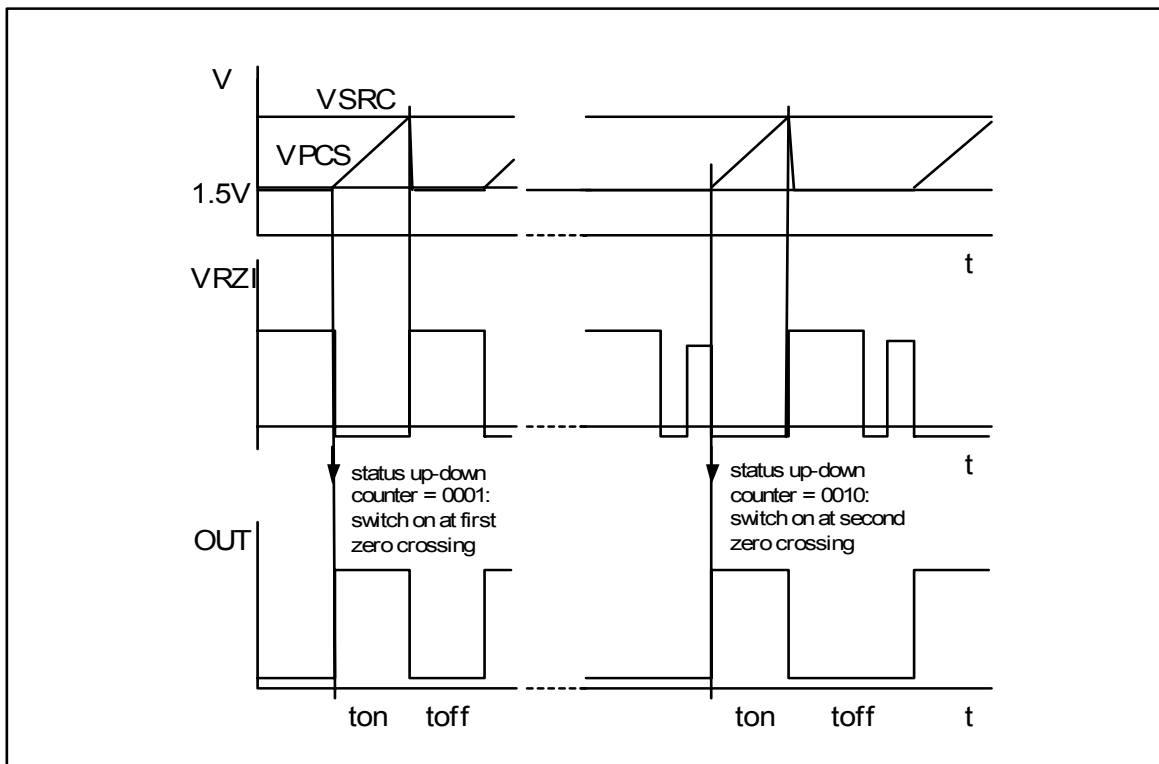

Ringing suppression

When V_{PCS} reaches the feedback voltage V_{SRC} the gate drive OUT is set to low and the ringing suppression timer is started. This timer ensures that the gate drive cannot be switched on until this ringing suppression time is passed. Duration of ringing suppression time depends on the V_{RZI} voltage. Suppression time is 3 μsec if $V_{RZI} > 1\text{V}$ and it is 30 μsec if $V_{RZI} < 1\text{V}$.

Figure: Ringing Suppression

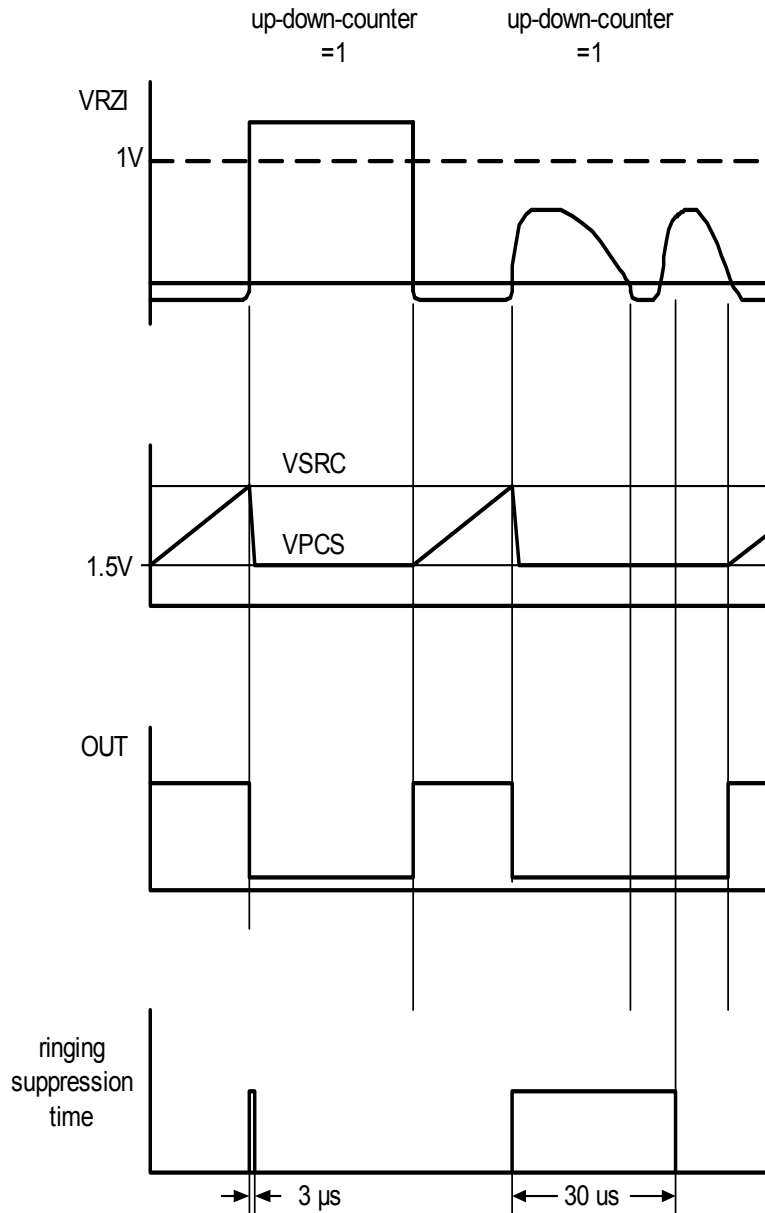

Primary regulation

Primary regulation is achieved by activating the internal current sink. The current sink is connected between pin SRC and ground. If V_{RZI} exceeds the 5V threshold the current sink is switched on. It is switched off when V_{RZI} falls below 5V. The current sink discharges the C_{SRC} capacitor. C_{SRC} is charged via the internal 20k resistor. If V_{RZI} exceeds the 4.4V threshold a flip-flop is set and the resistor is switched off when V_{RZI} falls below 50 mV. The resistor is switched on again with the falling slope of gate drive OUT.

Diagram Primary Regulation

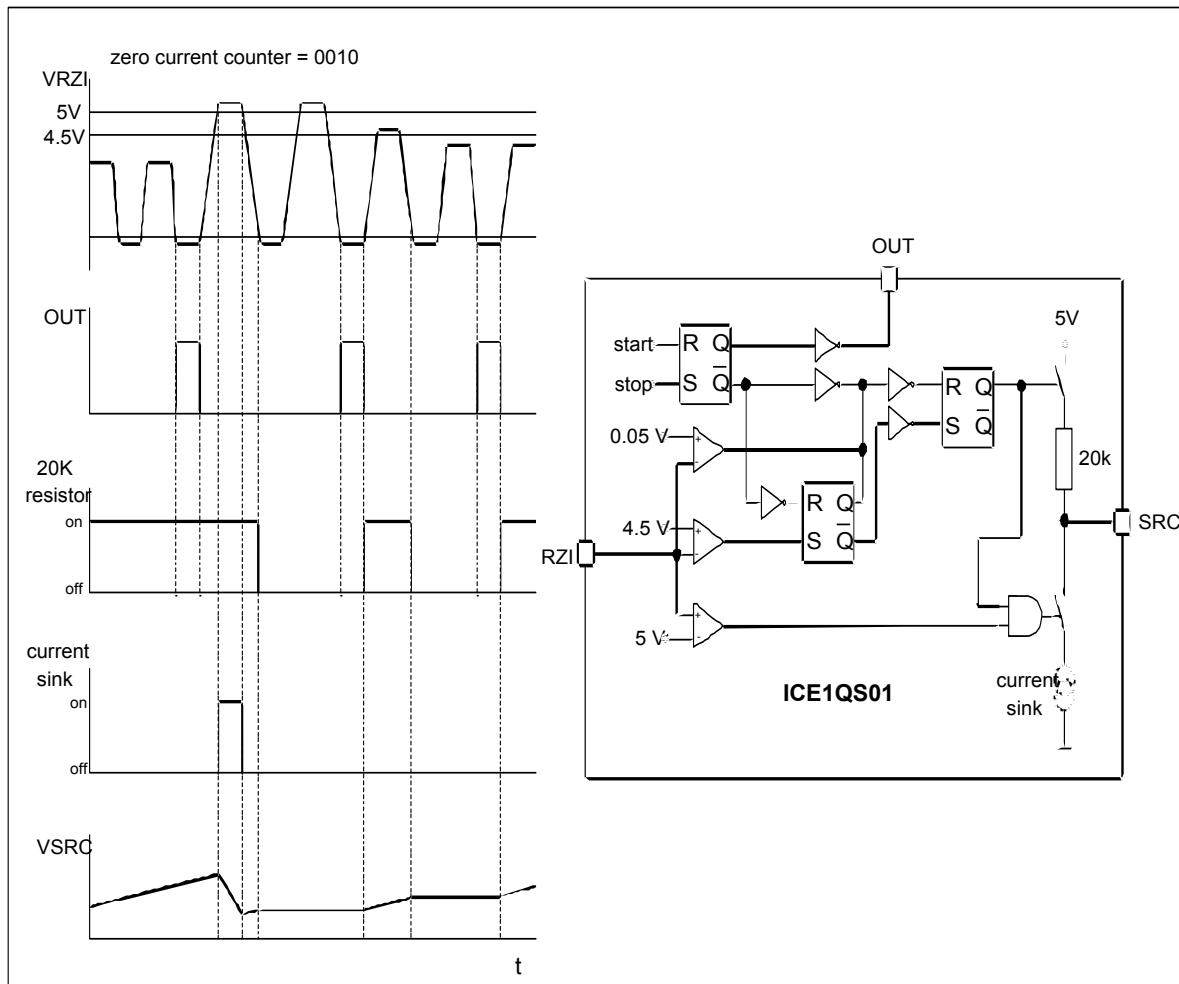

SRC (Regulation and soft start capacitor)

The feedback capacitor is connected to pin SRC. The feedback voltage V_{SRC} has two main functions.

Function I (MOS FET on time): V_{SRC} provides the switch off reference voltage. If V_{PCS} (which contains the primary current information) exceeds the V_{SRC} voltage the external MOS transistor is switched off.

Function II (MOS FET off time for frequency reduction): At low load the frequency is reduced by ignoring zero crossing signals after the transformer demagnetization. V_{SRC} determines the action of the 4-bit up-down-counter which contains the number of zero crossings to be ignored. The content of the up-down-counter is compared with the number of zero-current crossings of V_{RZI} . If the number of zero-current crossings in each period after the transformer demagnetization is equal to the up-down-counter content the MOS is switched on. At low load conditions when V_{SRC} is below 3.5V the counter is increased by one every 50 msec. The result is that the MOS transistor off-time increases and duty cycle decreases. At high load conditions when V_{SRC} is higher than 4.4V the counter content is reduced by one every 50msec. So MOS transistor off-time will be reduced. With this off-time regulation switching jitter can be eliminated.

The up-down-counter is immediately set to 0001 if a load jump occurs and V_{SRC} exceeds 4.8 V. This ensures that full power can be provided instantaneously.

The following table shows the SRC voltage range and the corresponding up-down counter action.

SRC voltage range	up-down-counter action
1: $V_{SRC} < 3.5V$	count forward
2: $3.5 < V_{SRC} < 4.4$	stop count
3: $V_{SRC} > 4.4$	count backward
4: $V_{SRC} > 4.8$	set up-down-counter to 1

The information provided by V_{SRC} is stored in two independent flip flops. An internal timer creates a trigger pulse with a period of 50 msec. Every time the pulse occurs the up-down counter checks the status flip flops and acts depending on the flip flop information. After this pulse the flip flops are reset. So change of voltage range is noticed by the logic only once during the 50 ms period. In the diagram below the behaviour of the up-down counter is depicted in more detail.

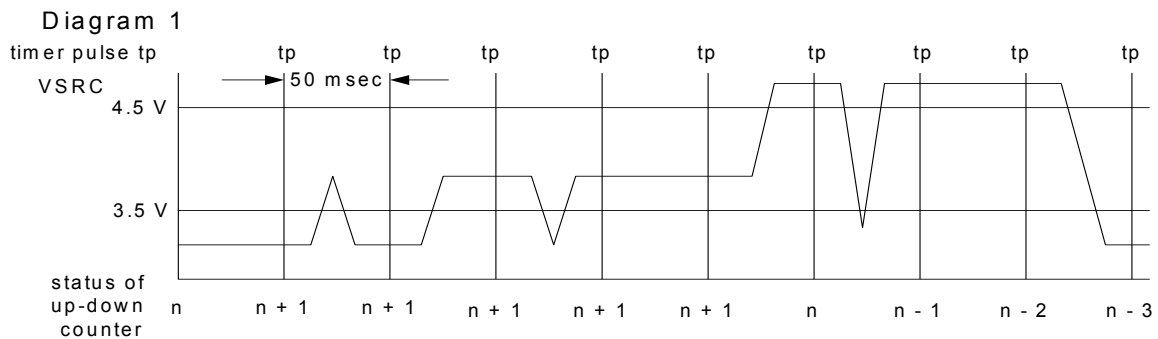

Burst mode

12 μ sec after beginning of softstart the burst mode comparator is activated. If V_{SRC} falls below 2V after activating the comparator the gate drive OUT is switched to low and the V_{CCoff} threshold is changed to 14.5 V. V_{CC} decreases because gate drive is held low. If V_{CC} reaches the V_{CCoff} threshold the IC is going into start-up mode. At V_{CCon} threshold the IC is switched on again starting with soft start modus. V_{CCoff} threshold is set to the normal 9V.

Figure: Burst Mode

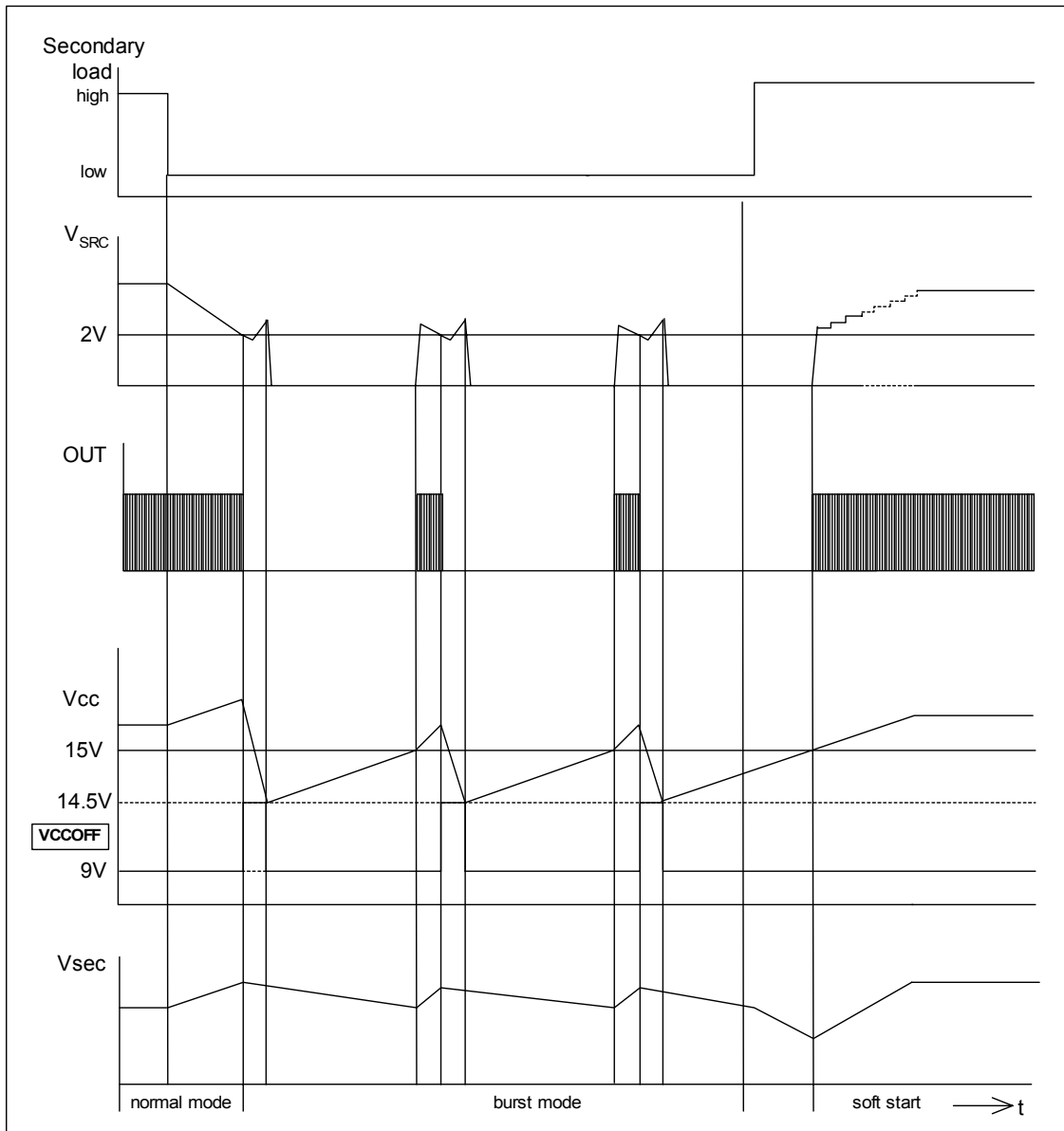

Restart timer

If voltage V_{RZI} is lower than 50 mV and gate drive OUT is low an internally created restart pulse will switch gate drive OUT high every 50 μ s and the minimum switching frequency is about 20 kHz.

Restart pulse is inhibited if V_{RZI} is higher than 50 mV. So the MOS transistor cannot be switched on until the transformer is discharged.

VCC overvoltage protection

If V_{CC} exceeds the V_{CCD} threshold a latch is set and the gate is disabled. Reset of latch occurs when V_{CC} is falling below $V_{CCon} - V_{CCBHY}$.

Overvoltage fault comparator (OFC)

With an external sense resistor connected to pin OFC primary current can be sensed directly. If the sensed current exceeds the internal V_{OFC} threshold a latch is set and gate is disabled. Reset of latch occurs when V_{CC} is falling below $V_{CCon} - V_{CCBHY}$.

Notice: If this comparator is not used pin OFC has to be connected to ground.

Mains undervoltage

Power supplies must be shut down when mains voltage is below a certain limit to avoid too long on-time of MOS-FET switch, which would lead to a switching frequency in audible spheres. Mains undervoltage is sensed during the off-time of the MOS-FET switch. If the current flowing into pin PCS is smaller than 100 μ A, then the output is latched and cannot be switched to high state.

Diagram Mains Undervoltage Lockout Current

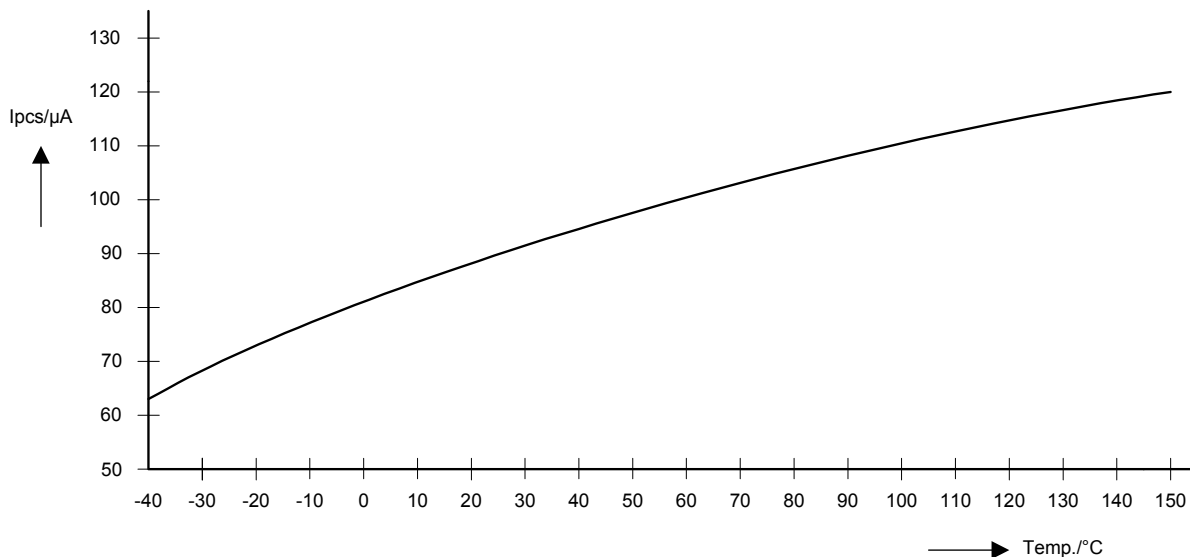

Fold back point correction

With increasing mains voltage the switch on time becomes shorter and so the frequency becomes higher. With higher frequency also the maximal possible output power becomes higher. With higher power the danger in case of failure increases.

To avoid this, the foldback point correction circuit senses main voltage to reduce the on-time of the switch. Mains voltage is sensed at the supply coil of V_{CC} voltage via a resistor connected to pin RZI. During on-time of the MOS-FET switch current is pulled out from pin RZI. When this current is higher than $500 \mu A$, one fifth of the current higher than this threshold is driven into pin PCS to increase the voltage slope charging the capacitor connected to this pin.

$$I_{PCSFO} = \frac{IRZI - 0,5mA}{5}, (IRZI > 500\mu A)$$

Figure: Fold Back Point Correction

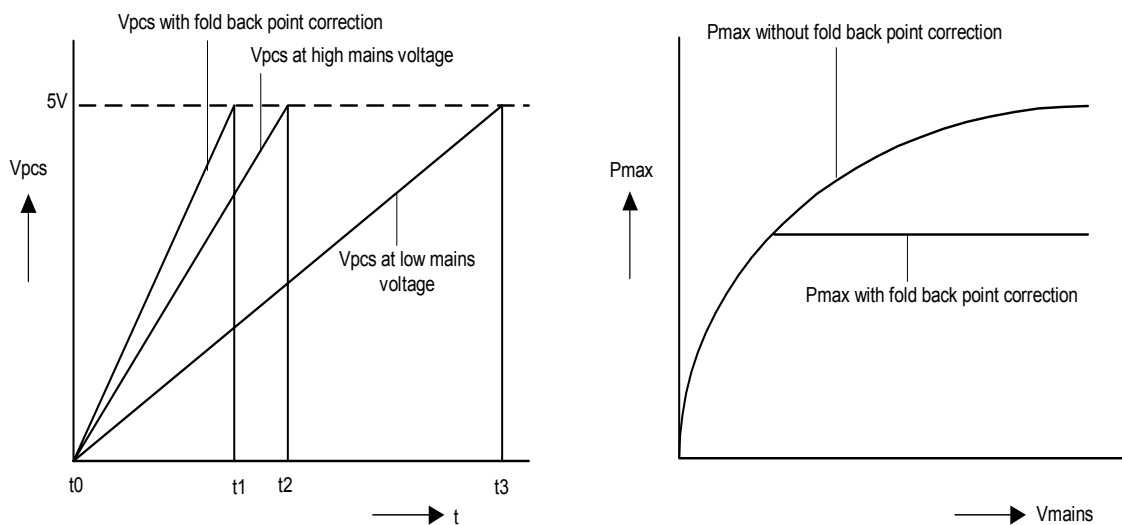

Absolute Maximum Ratings

Parameter	Symbol	Min	Max	Unit	Remark
Charge Current into Pin2	I_{PCS}		500	uA	During start up
Voltage at Pin 2	V_{PCS}	-0.3	21	V	
Current into Pin 3	I_{RZI} I_{RZI}	-10	10	mA mA	$V_{RZI} > V_{RZICH}$ $V_{RZI} < V_{RZICL}$
Voltage at Pin 4	V_{SRC}	-0.3	V_{SRCCL}	V	$I_{SRC} = 100 \mu A$
Voltage at Pin 5	V_{OFC}	-0.3	6	V	
Current into Pin 7	I_{OUT}	-500	500	mA	$t < 1ms$
Voltage at Pin 8	V_{CC}	-0.3	21	V	
ESD Protection			4000	V	MIL STD 883C method 3015.6, 100pF, 1500Ω
Storage Temperature	T_{stg}	-50	150	°C	
Operating Junction Temperature	T_J	-25	150	°C	
Thermal Resistance Junction-Ambient	R_{thJA}		100	K/W	P-DIP-8

Characteristics (Unless otherwise stated, $-25^{\circ}\text{C} < T_j < 150^{\circ}\text{C}$, $V_{CC} = 16\text{V}$)

Parameter	Symbol	min.	typ.	max.	Unit	Test Condition
VCC start-up circuit						
Start-up supply current	I_{CCL}		60	100	μA	$V_{CC} = V_{CCon} - 0.5\text{V}$
Operating supply current	I_{CCH}	8	11	12.5	mA	Output low
V_{CC} Turn-On threshold	$V_{CC ON}$	14.1	15	15.5	V	
V_{CC} Turn-Off threshold	$V_{CC OFF}$	8.5	9	9.5	V	
V_{CC} Hysteresis	V_{CCHY}	5.4	6	6.5	V	
V_{CC} Burst Hysteresis	V_{CCBHY}	0.2	0.4	0.6	V	
V_{CC} Overvoltage	V_{CCD}	19	20	21	V	
SRC soft start mode						
Start Voltage	V_{SRC1}	2.40	2.65	2.85	V	$I_{\text{optocoupler}} = 0 \mu\text{A}$
Digital voltage step	V_{SRCST}		360		mV	$I_{\text{optocoupler}} = 0 \mu\text{A}$
Step pulse rate	t_{SRCSTR}		3		ms	
Soft start time	t_{ST}	19	24	32	ms	
Current source rise time	t_{STRT}		14		μs	$V_{SRC} = 0.2\text{V to } 2.0\text{V}$ $C_{SRC} = 10\text{nF}$
Current source on time	t_{STOT}		12		μs	
SRC normal mode						
Source resistor	R_{SRC}	17	21	28	$\text{k}\Omega$	
Clamping threshold voltage	V_{SRCCL}	4.95	5.1	5.25	V	$V_{PCS} = V_{SRC}$, OUT switches to Low, $I_{SRC} = 100\mu\text{A}$
Reset counter to one	V_{SRCR}	4.75	4.9	5.05	V	
Distance clamping to reset	V_{SRCH}	150	200	250	mV	
Threshold downward count	V_{SRCD}	4.3	4.5	4.7	V	
Threshold upward count	V_{SRCSU}	3.4	3.5	3.7	V	
Burst mode latch threshold voltage	V_{SRCB}	1.9	2.05	2.2	V	$V_{SRC} < V_{SRCB}$: OUT=Low
Counter time ¹⁾	t_{COUNT}		50		msec	
Sink current prim reg mode	I_{SRCS}	400	500	550	μA	$V_{RZI} > 5\text{V}$
1) The parameter is not subject to production test - verified by design/characterization						

Parameter	Symbol	min.	typ.	max.	Unit	Test Condition
RZI (regulation and zero crossing input)						
Zero crossing threshold voltage	V_{RZIT1}	25	50	80	mV	$V_{RZI} < V_{RZIT1}$: Out=High
Time delay switch on	t_{don}	350	440	550	nsec	
Leakage current	I_{RZIB}	-1	25	110	μ A	$V_{RZI}=5V$
Clamping voltage low state	V_{RZICL}	-0.5	-0.3	-0.2	V	$I_{RZI} = -1mA$
Clamping voltage high state	V_{RZICH}	5.5	6.0	6.4	V	$I_{RZI} = 5mA$
Primary regulation threshold for discharge current	V_{RZIDC}	4.95	5.1	5.25	V	
Primary regulation threshold for charge current	V_{RZICC}	4.2	4.4	4.65	V	
Ringing suppression threshold voltage	V_{RZIT2}	0.9	1.0	1.1	V	
Ringing suppression time	t_{RZIPS} t_{RZIPL}	1.5 20	2.5 29	3.2 37	μ sec μ sec	$V_{RZI} > V_{RZIT2}$ $V_{RZI} < V_{RZIT2}$
Foldback point correction current threshold	I_{PCSF}	250	400	600	μ A	$-25^{\circ}C < T_j < 120^{\circ}C$
PCS (primary current simulation)						
Gate enable threshold voltage	V_{PCSE}	0.9	1.0	1.1	V	$V_{PCS} < V_{PCSE}$: Out=Low
Basic voltage	V_{PCSB}	1.45	1.55	1.65	V	gate low
Shut down delay	t_{PCS}		150	230	nsec	
Mains undervoltage lock-out current 2)	I_{PCS}	40	100	160	μ A	
Voltage drop startup diode	V_{PCSD}		0.85		V	$I_{PCS}=300\mu A$
Discharge current	I_{PCSD}	1.6	2.6	3.6	mA	$V_{PCS}=3V$
OFC (overcurrent fault comparator)						
Bias Current	I_{OFCB}	-1			μ A	
Gate drive disabled threshold voltage	V_{OFC}	0.93	1.0	1.05	V	
Shut Down Delay	t_{OFC}		180	240	ns	
2) See diagram mains undervolt. lockout current						

Parameter	Symbol	min.	typ.	max.	Unit	Test Condition
Restart Timer						
Restart time	t_{RES}	33	42	55	μs	$V_{RZI} < 25mV$
Gate Drive						
Output voltage low			0.7 0.8	1.1 1.4	V V	$I_{OUT}=20mA$ $I_{OUT}=200mA$
Output voltage high		9.5 9.5	10.6 10.5	11.0 11.0	V V	$I_{OUT}=-20mA$ $I_{OUT}=-180mA$
Output voltage active shut down			1.0	1.35	V	$V_{CC}=7V$ $I_{OUT}=20mA$
Rise time			40	100	ns	$C_{OUT}=1nF$
Fall time			60	120	ns	$C_{OUT}=1nF$

Figure: Circuit Diagram for Standard Application with PFC

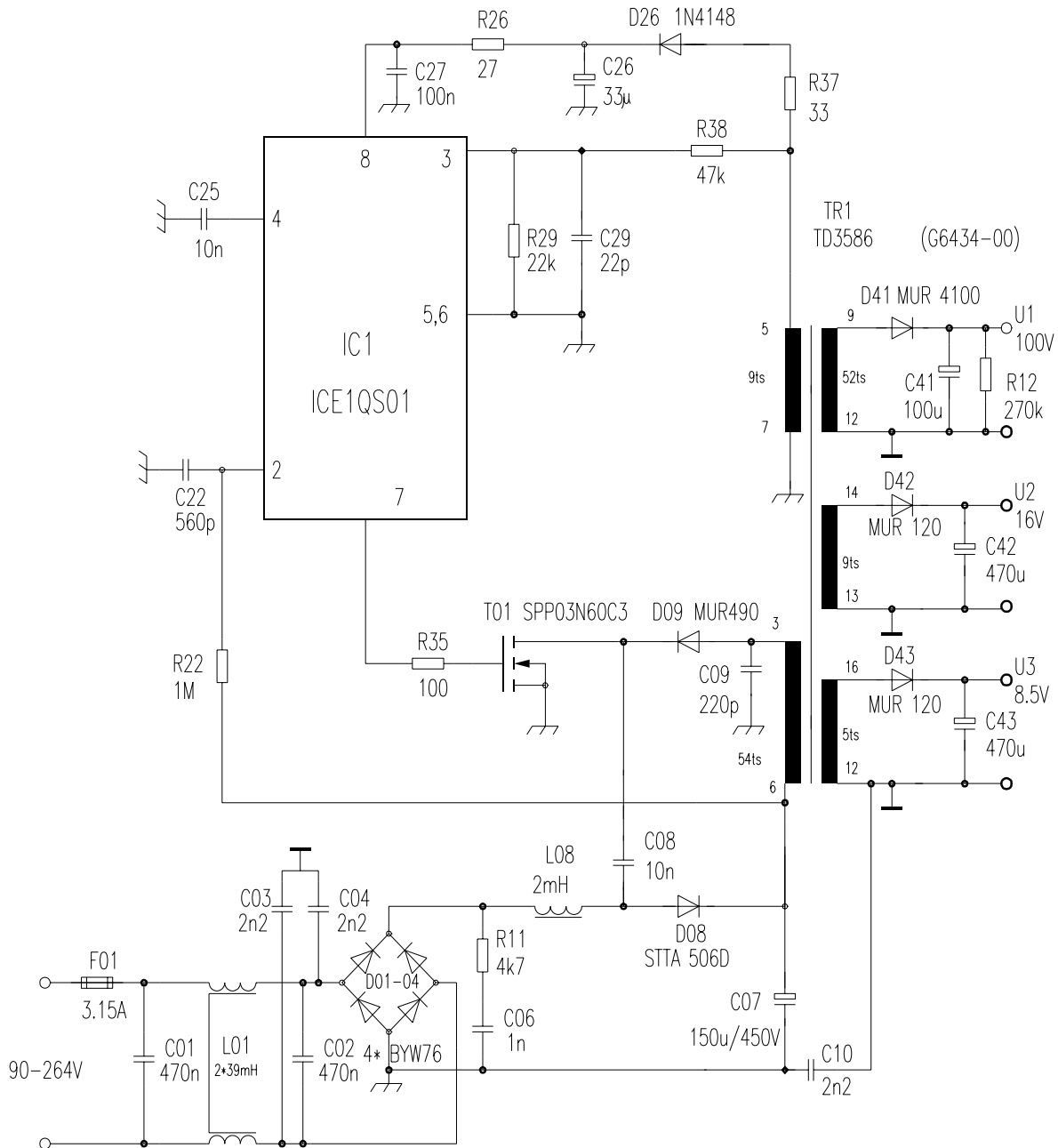
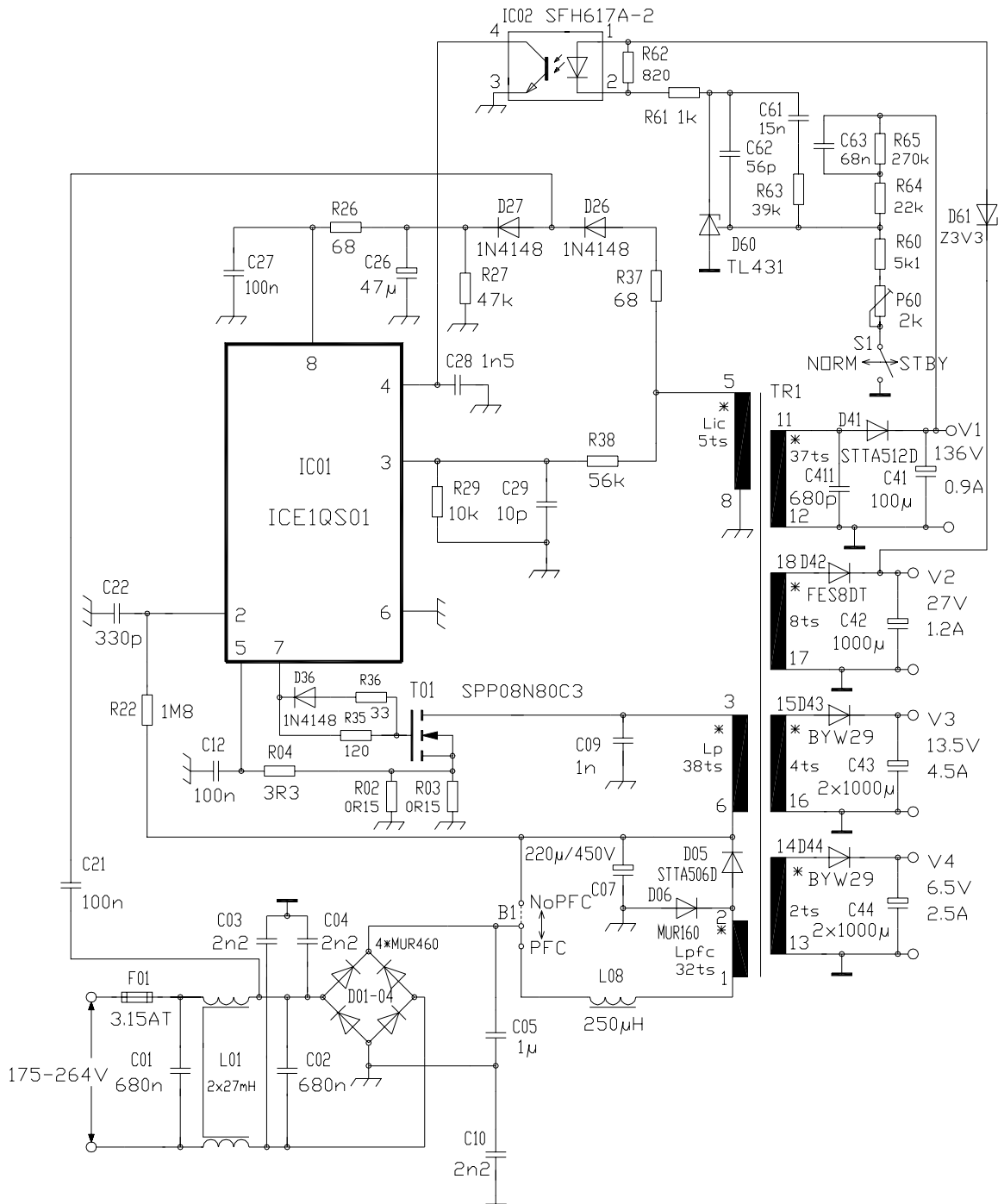
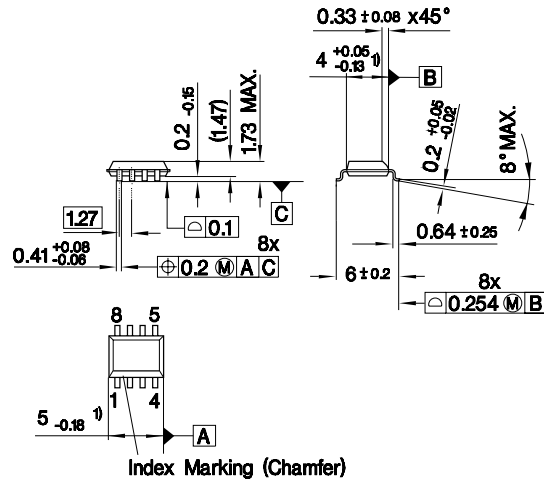

Figure: Circuit Diagram for Application with PFC and Low Voltage Standby Mode



Plastic Package, P-DSO-8-3
(Plastic Dual Small Outline Package)



1) Does not include plastic or metal protrusion of 0.15 max. per side

GPS05121

Plastic Package, P-DIP-8-4
(Plastic Dual In-line Package)

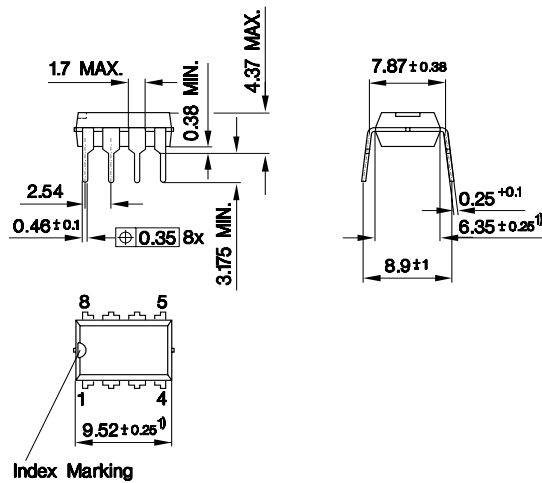

1) Does not include plastic or metal protrusion of 0.25 max. per side

GPD05025

Sorts of Packing

Package outlines for tubes, trays etc. are contained in our Data Book "Package Information".

SMD = Surface Mounted Device

Dimensions in mm