

## Boost Controller for LED Backlighting

REV: 00

### General Description

The LD7400 is an asynchronous current mode boost controller, can operate over a wide input range from 10.5V to 28V. The current mode architecture improve It's ideal to program the brightness of LED Backlight or LED lighting and can efficiently manage Power MOSFET thermal transient response and simplify the loop compensation.

The Device features internal slope compensation, input voltage under-voltage lockout, output voltage short circuit protection, cycle-by-cycle current limit, programmable oscillator frequency, and thermal shutdown protection.

The LD7400 is available in an SOP-8 package.

### Features

- Wide Input Range: 10.5V to 28V
- Current Mode Control
- 0.5V Current Sensing Reference
- Adjustable Switching Frequency Setting
- PWM Dimming Input
- Internal Slope Compensation
- Cycle-by-Cycle Current Limit
- Over Temperature Protection

### Applications

- LED TV Backlight
- LED Monitor Backlight
- LED lighting

### Typical Application

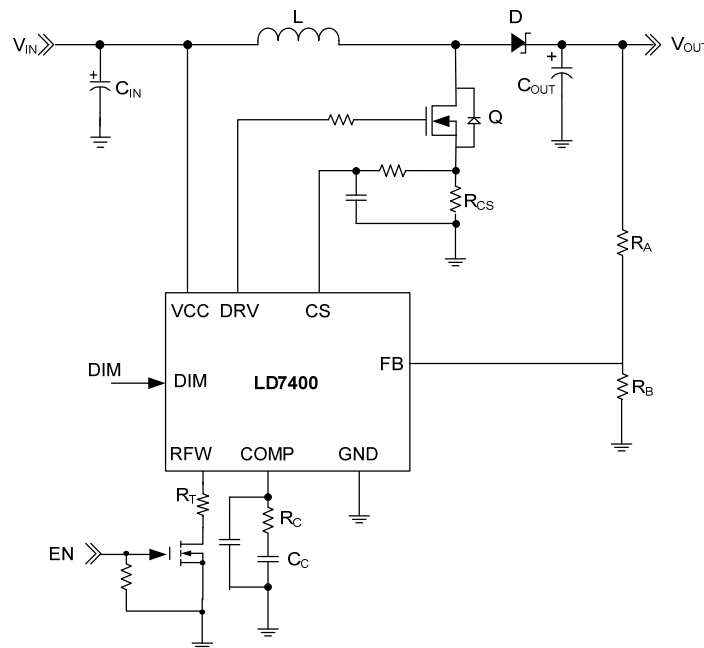
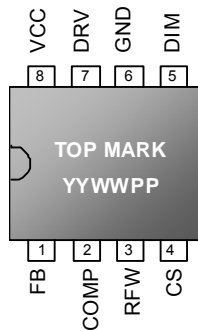

Fig. 1: Application circuit

## Pin Configuration

SOP-8 (TOP VIEW)



YY: Year code (D:2004, E:2005...)  
 WW: Week code  
 PP: Production code

## Ordering Information

| Part number | Package | Top Mark | Shipping          |
|-------------|---------|----------|-------------------|
| LD7400GS    | SOP-8   | LD7400GS | 2500 /tape & reel |

The LD7400 is green packaged.

## Pin Descriptions

| PIN | NAME | FUNCTION  |
|-----|------|---|
| 1   | FB   | Feedback input. Connect a divider resistor from output to this pin to set the output voltage.   |
| 2   | COMP | Compensation of the error amplifier for voltage loop compensation.  |
| 3   | RFW  | Operating Frequency setting. Connect a resistor from this pin to ground to set the boost switching frequency. The controller will be shutdown soon as it detects this pin floating.   |
| 4   | CS   | Current Sense pin, Connect an current sensing resistor to GND. The voltage on this pin is used to provide current feedback in the control loop and detect a condition of overcurrent. |
| 5   | DIM  | PWM Dimming Input. If the DIM pin voltage is below logic Voltage threshold, the DRV control would be stopped immediately until DIM pin voltage rises to high again.                   |
| 6   | GND  | Ground.   |
| 7   | DRV  | Gate drive output to drive the external MOSFET.   |
| 8   | VCC  | Power source VCC pin.   |

**Block Diagram**

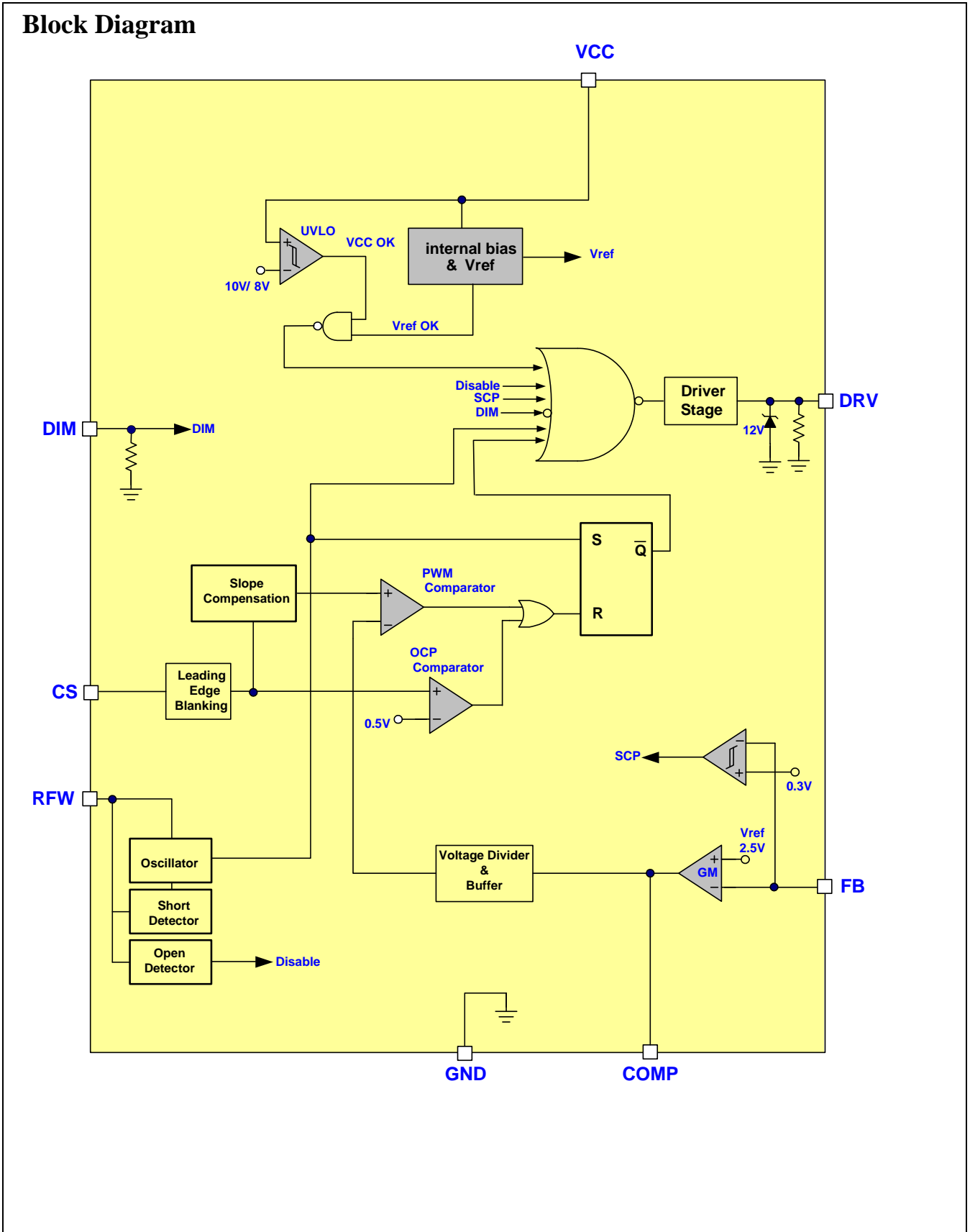

## Absolute Maximum Ratings

|  |                |
|--|----------------|
| VCC, DRV.....  | 30V            |
| All Other Pins .....                                     | -0.3V ~ 5.5V   |
| Power Dissipation, P <sub>D</sub> @85°C (SOP-8).....     | 250mW          |
| Package Thermal Resistance, θ <sub>JA</sub> (SOP-8)..... | 160°C/W        |
| Operating Temperature Range.....                         | -40°C to 85°C  |
| Storage Temperature Range.....                           | -55°C to 125°C |
| Junction Temperature.....                                | 125°C          |
| Lead Temperature (Soldering, 10sec) .....                | 260°C          |
| ESD Level (Human Body Model).....                        | 2KV            |
| ESD Level (Machine Model).....                           | 200V           |

## Recommended Operating Conditions

|                           |                |
|---------------------------|----------------|
| Input Supply Voltage..... | 10.5V to 28V   |
| DIM Frequency .....       | 100Hz to 800Hz |

### Caution:

Stresses beyond the ratings specified in "Absolute Maximum Ratings" may cause permanent damage to the device. This is a stress only rating and operation of the device at these or any other conditions above those indicated in the operational sections of this specification is not implied.

## Electrical Characteristics1

( $V_{IN}=12V$ ,  $T_A=25^{\circ}C$ , unless otherwise noted.)

| PARAMETER                             | CONDITIONS                       | MIN. | TYP. | MAX. | UNITS       |
|---------------------------------------|----------------------------------|------|------|------|-------------|
| <b>Input Power</b>                    |                                  |      |      |      |             |
| Turn On Level                         | UVLO(on)                         | 9.5  |      | 10.4 | V           |
| Turn Off Level                        | UVLO(off)                        | 8    |      | 8.5  | V           |
| Shutdown Current                      | $R_{FW}$ =Floating               |      | 40   |      | $\mu A$     |
| Standby Current                       | DIM=Low                          |      | 1    |      | mA          |
| Operating Current                     | DIM=High<br>Switching at no load |      | 5    |      | mA          |
| <b>Boost Converter</b>                |                                  |      |      |      |             |
| Adjustable Switching frequency        |                                  | 100  |      | 1000 | KHz         |
| Switching frequency                   | $R_{FW}=350k\Omega$              | 145  | 174  | 200  | KHz         |
| Boost Maximum duty cycle              | Switching frequency=300KHz       | 85   | 90   | 95   | %           |
| DRV gate drive                        | Source current, $V_{IN}=12V$     |      | 1.2  |      | A           |
|                                       | Sink current, $V_{IN}=12V$       |      | 1.3  |      | A           |
| Output High Clamp Level               | $V_{CC}=24V$                     |      | 12   |      | V           |
| DRV pin Rising Time                   | DRV pin load=1nF                 |      | 50   | 150  | ns          |
| DRV pin Falling Time                  | DRV pin load=1nF                 |      | 50   | 150  | ns          |
| <b>Feedback (FB)</b>                  |                                  |      |      |      |             |
| Reference Voltage                     |                                  | 2.45 | 2.5  | 2.55 | V           |
| <b>PWM Dimming (DIM)</b>              |                                  |      |      |      |             |
| DIM Voltage threshold                 | Enabled                          | 2    |      |      | V           |
|                                       | Disabled                         |      |      | 1    | V           |
| Resistance from DIM pin to GND        |                                  |      | 600  |      | $k\Omega$   |
| PWM dimming frequency                 |                                  | 100  |      | 1000 | Hz          |
| Dimming Duty-Cycle                    |                                  | 0    |      | 100  | %           |
| <b>Current Sensing (CS)</b>           |                                  |      |      |      |             |
| Current Sense Input Threshold Voltage |                                  |      | 0.5  |      | V           |
| LEB time                              |                                  |      | 250  |      | ns          |
| <b>Over Temperature Protection</b>    |                                  |      |      |      |             |
| OTP Trip Point                        |                                  |      | 150  |      | $^{\circ}C$ |
| De-bounce Point                       |                                  |      | 30   |      | $^{\circ}C$ |

## Typical Performance Characteristics

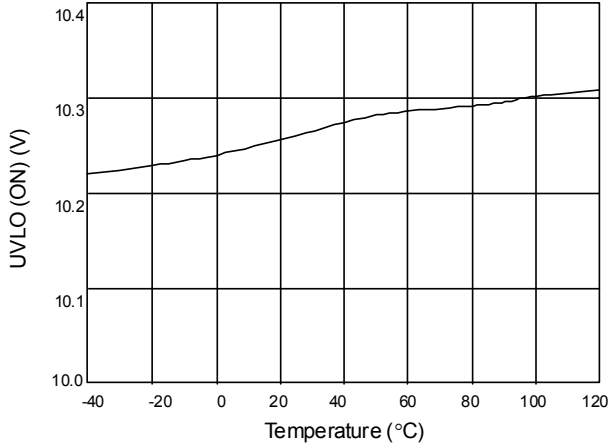

Fig. 2 UVLO (ON) vs. Temperature

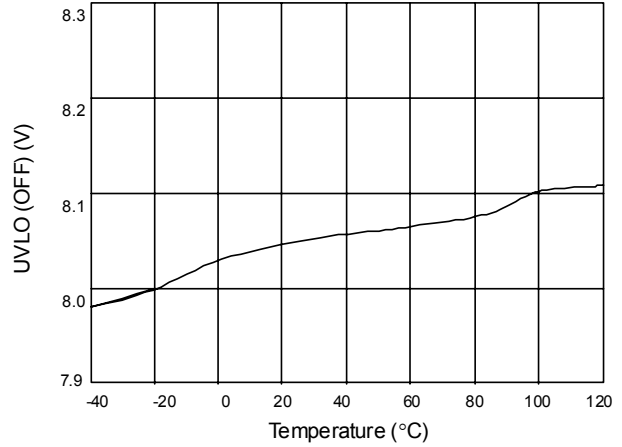

Fig. 3 UVLO (OFF) vs. Temperature

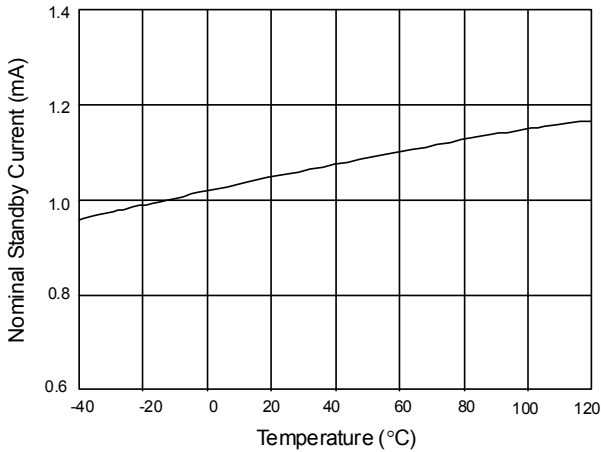

Fig. 4 Quiescent current vs. Temperature

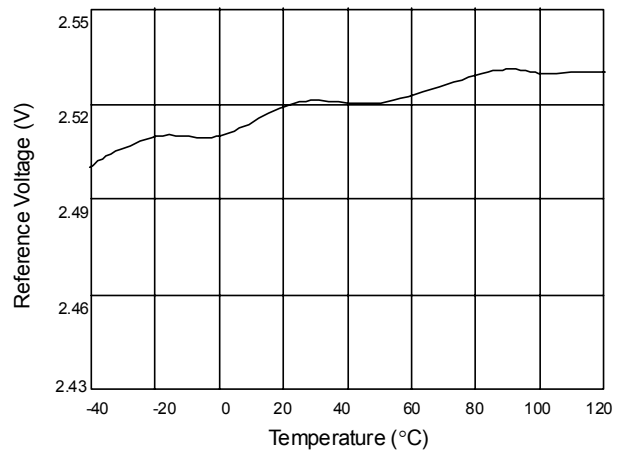

Fig. 5 Reference Voltage vs. Temperature

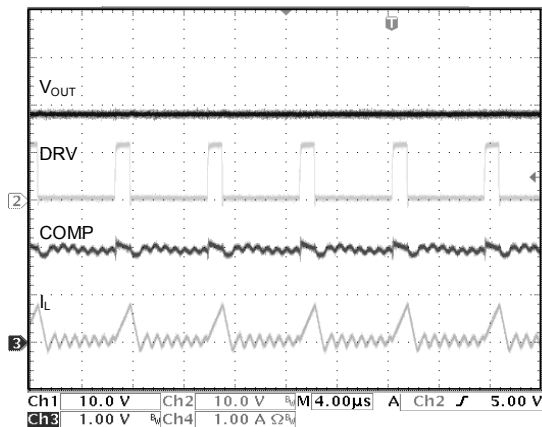

Fig. 6  $I_{OUT}=30\text{mA}$ ; "Stability Operation"

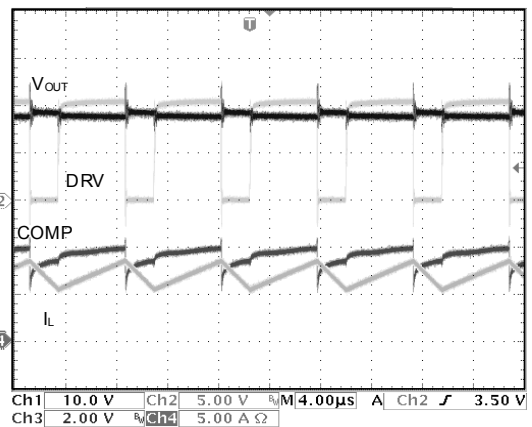

Fig. 7  $I_{OUT}=2.0\text{A}$ ; "Stability Operation"

Note (Fig. 6, 7):

$V_{IN}=16\text{V}$ ,  $V_{OUT}=50\text{V}$ ,  $C_{IN}=220\mu\text{F}$ ,  $C_{OUT}=33\mu\text{F}\times 2$ ,  $L=47\mu\text{H}$ ,  $F_{REQ}=140\text{KHz}$ ,  $\text{COMP}=60\text{k}\Omega+100\text{nF}$ , unless otherwise noted

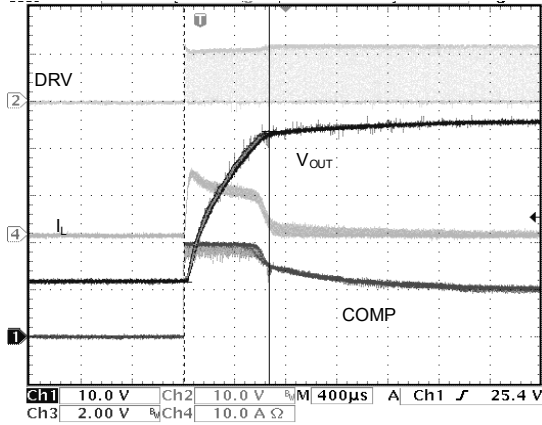

Fig. 8  $I_{out}=0mA$ ; "Power ON Sequence"

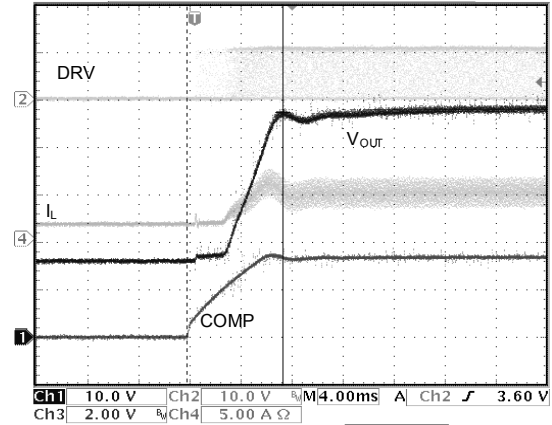

Fig. 9  $I_{out}=2A, COMP=60k+100nF/100nF$  "Power ON"

Note (Fig. 8, 9):

$V_{IN}=16V, V_{OUT}=50V, C_{IN}=220\mu F, C_{OUT}=33\mu F \times 2, L=47\mu H, FREQ=140KHz, COMP=60k\Omega+100nF$ , unless otherwise noted

## Application Information

### Operation Overview

The LD7400 is a current-mode control power converter, featuring current-mode control, cycle-by-cycle current limit and simplified loop compensation.

### Output Drive Stage

An output stage of CMOS buffer, with typical 1.2A/1.3A driving capability, is incorporated to drive a power MOSFET directly. The output voltage is clamped at 12V to protect the MOSFET gate even if VCC voltage ramps higher than 12V.

### Under Voltage Lockout (UVLO)

An UVLO comparator is implemented in it to detect the voltage over VCC pin. It would assure the supply voltage enough to turn on the LD7400 and further to drive the power MOSFET. As shown in Fig. 10, a hysteresis is built in to prevent shutdown from the voltage dip during start-up. The turn-on and turn-off threshold level are set at 10.0V and 8V, respectively.

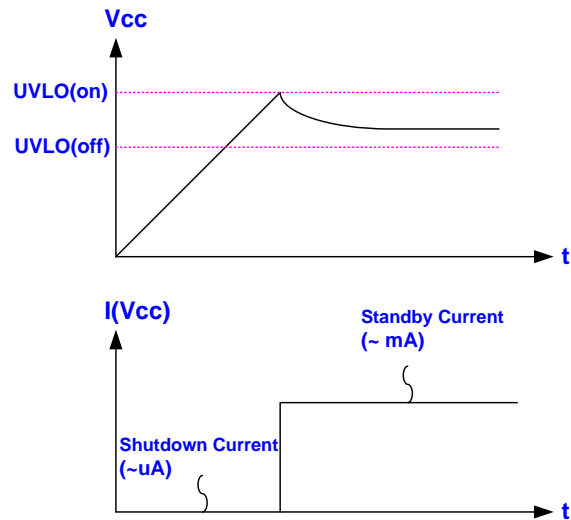

Fig. 10

### Output Voltage Setting

The LD7400 monitors the output voltage signal over FB pin through a pair of resistor divider, RA and RB. The output voltage is determined by the following relationship.

$$V_{OUT} = 2.5V \left(1 + \frac{R_A}{R_B}\right)$$

RA and RB are values for top and bottom feedback

resistors, respectively. See below.

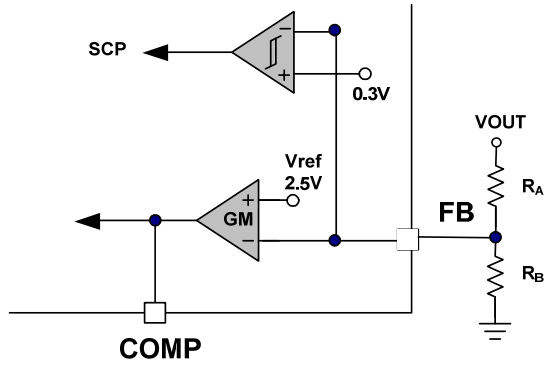

Fig. 11

### Switching Frequency Selection

LD7400 can operate in fixed frequency mode. The constant operation frequency is set by the external resistor connected between RFW pin and ground. The resistor sets the charging current for internal oscillator.

$$F_{SW} \text{ (kHz)} = \frac{70750}{[RT \text{ (k}\Omega)]} - 28.3$$

For example, a 350kΩ RT sets switching frequency to 173kHz.

### Dimming Control

The DIM pin delivers an external PWM signal to control the switching status. When DIM pin is at high, the switching work normally, otherwise it will cease the switching.

### Current Sensing and Leading-edge

#### Blanking

The LD7400 detects the primary MOSFET current over CS pin for cycle-by-cycle current limiting. The maximum voltage threshold of the current sensing pin is set at 0.5V. From above, the MOSFET peak current can be obtained from below.

$$I_{PEAK(MAX)} = \frac{0.5V}{R_{CS}}$$

A 250ns leading-edge blanking (LEB) time is included in the input of CS pin to prevent false-triggering from current spike. The R-C filter is eliminatable in some low power applications, or in cases that the pulse width of the turn-on

spikes is below 250ns and the negative spike on the CS pin is below -0.5V.

However, the pulse width of the turn-on spike is determined according to the output power, circuit design and PCB layout. It is strongly recommended to adopt a smaller R-C filter for higher power application to avoid the CS pin being damaged by the negative turn-on spike.

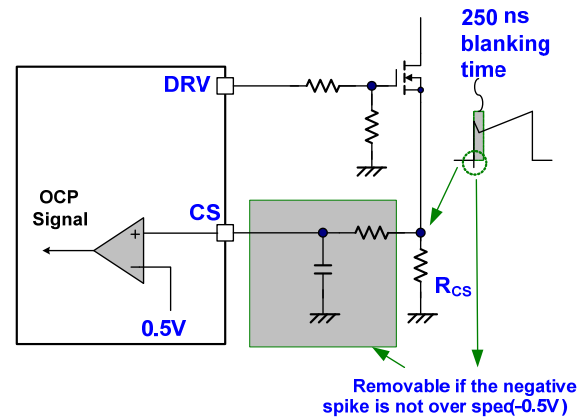

Fig. 12

### Thermal Protection

Thermal protection limits total power dissipation in this device. When the junction temperature reaches 150°C approximately, the thermal sensor signals the shutdown logic turning off this device. The thermal sensor will turn this device on again after the IC's junction temperature is decreased by 30°C

### PCB Layout Guideline

It's recommended to separate the high frequency switching current from the low-level control signals in layout. The high switching current (MOSFET, inductor, gate driver and FB return ends) may disturb the other low-level signals in the feedback loop and protection circuitry. As a result, it may cause the control function to behave abnormally. To avoid these issues, a few guidelines are recommended for the PCB layout, as below.

1. The VIN bypass capacitor connected with signal ground must be placed close around the IC as possible. The traces between capacitor and VIN pin should be routed as short as possible to avoid noise interference.



2. Use broader traces for  $V_{IN}$ ,  $V_{OUT}$  and power ground. Those components connected to  $V_{IN}$ ,  $V_{OUT}$  and power ground, such as power MOSFET and decoupling capacitors, carry high input/output current. To minimize power loss in these traces, the resistance of traces should be as low as possible.
3. Use broader traces between power MOSFET drain, inductor and diode. These traces deliver high current. To minimize power loss in these traces, the resistance
- of traces should be as low as possible.
4. Keep the gate drive traces short and wide between the IC driver output, DRV pin, and the power MOSFET. The driving traces have a high current spike during inverter operation. To minimize power MOSFET switching loss or oscillation voltage in the gate driver signal, the drive traces should be as wide and short as possible to minimize resistance and parasitic inductance.

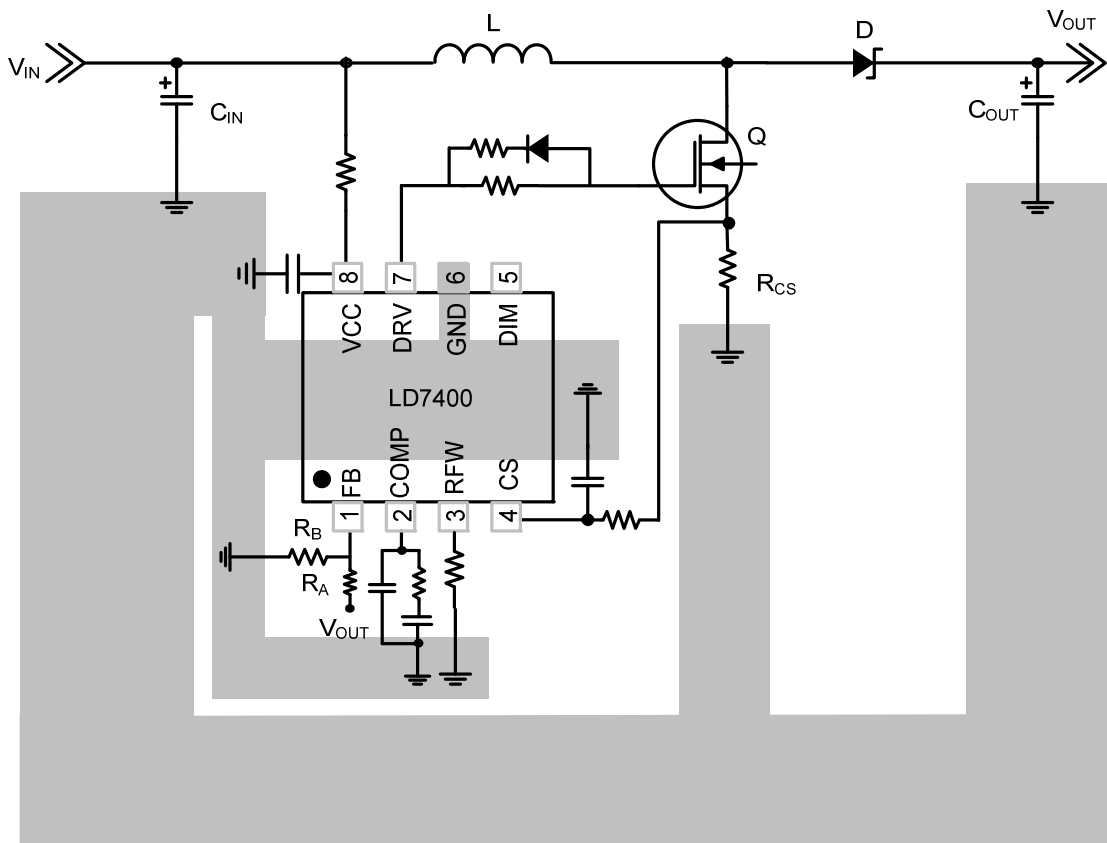
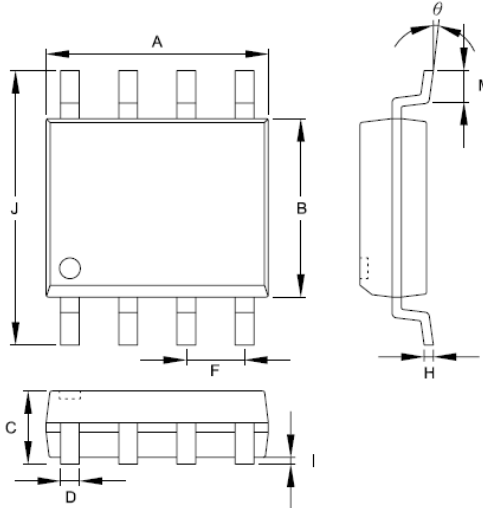

Fig. 13 Recommended PCB layout

## Package Information

### SOP-8



| Symbols | Dimensions in Millimeters |       | Dimensions in Inch |       |
|---------|---------------------------|-------|--------------------|-------|
|         | MIN                       | MAX   | MIN                | MAX   |
| A       | 4.801                     | 5.004 | 0.189              | 0.197 |
| B       | 3.810                     | 3.988 | 0.150              | 0.157 |
| C       | 1.346                     | 1.753 | 0.053              | 0.069 |
| D       | 0.330                     | 0.508 | 0.013              | 0.020 |
| F       | 1.194                     | 1.346 | 0.047              | 0.053 |
| H       | 0.178                     | 0.254 | 0.007              | 0.009 |
| I       | 0.102                     | 0.254 | 0.004              | 0.010 |
| J       | 5.791                     | 6.198 | 0.228              | 0.244 |
| M       | 0.406                     | 1.270 | 0.016              | 0.050 |
| θ       | 0°                        | 8°    | 0°                 | 8°    |

### Important Notice

Leadtrend Technology Corp. reserves the right to make changes or corrections to its products at any time without notice. Customers should verify the datasheets are current and complete before placing order.

## IR Profile for SMD Devices

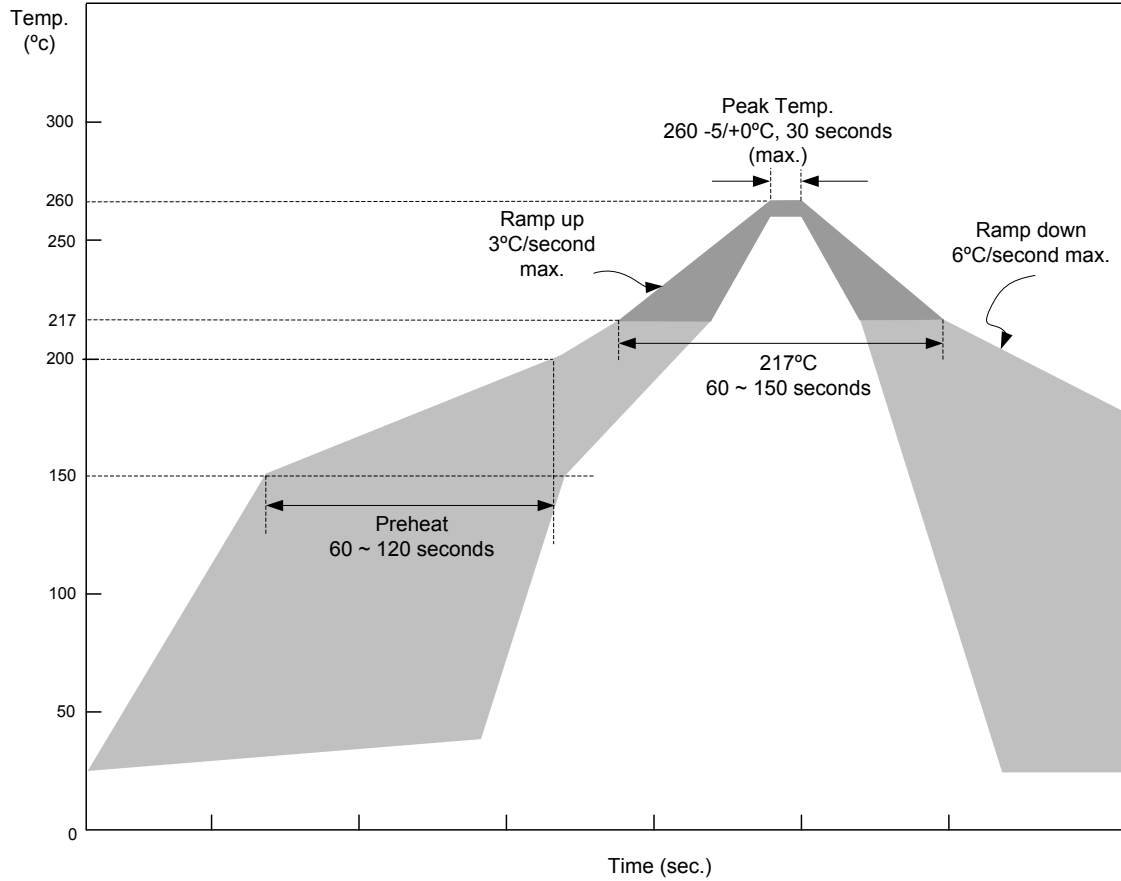

| Item     | Average Ramp-up Rate | Pre-heat (150 ~ 200°C) | Time Maintained Above 217°C | Peak Temp.                | Ramp-down Rate |
|----------|----------------------|------------------------|-----------------------------|---------------------------|----------------|
| Required | 3°C(max) /sec        | 60~120 sec             | 60~150 seconds              | 260 +0/-5°C<br>30 seconds | 6°C (max) /sec |

**Revision History**

| Rev. | Date       | Change Notice          |
|------|------------|------------------------|
| 00   | 02/23/2012 | Original Specification |