

DESCRIPTION

The LX8211A adjustable voltage linear regulator combines low dropout, high accuracy, very low ground current and fast response in a very small footprint.

Using the Enable pin the regulator is switched on with TTL logic levels, which is especially useful for battery-operated equipment. Other features include independent thermal and short circuit current protection. The regulator is stable with a low value ceramic output capacitor.

The PNP output transistor allows for ultra low dropout typically less than 140mV at 100mA.

IMPORTANT: For the most current data, consult MICROSEMI's website: <http://www.microsemi.com>

KEY FEATURES

- Dropout Voltage Typically 140mV @ 100mA
- Ultra Low Shutdown Current Typically Less Than 1µA
- High Output Accuracy Trimmed to 0.25%
- Standard Pinout in SOT-23-5
- Current and Over Temperature Protection
- Stable With Low Cost Ceramic Output Capacitor

APPLICATIONS

- Battery Operated Systems
- Laptop, Notebook and PDA's
- Cellular Telephones / Pagers
- Hand-Held Instruments
- Linear post Regulators for SMPS

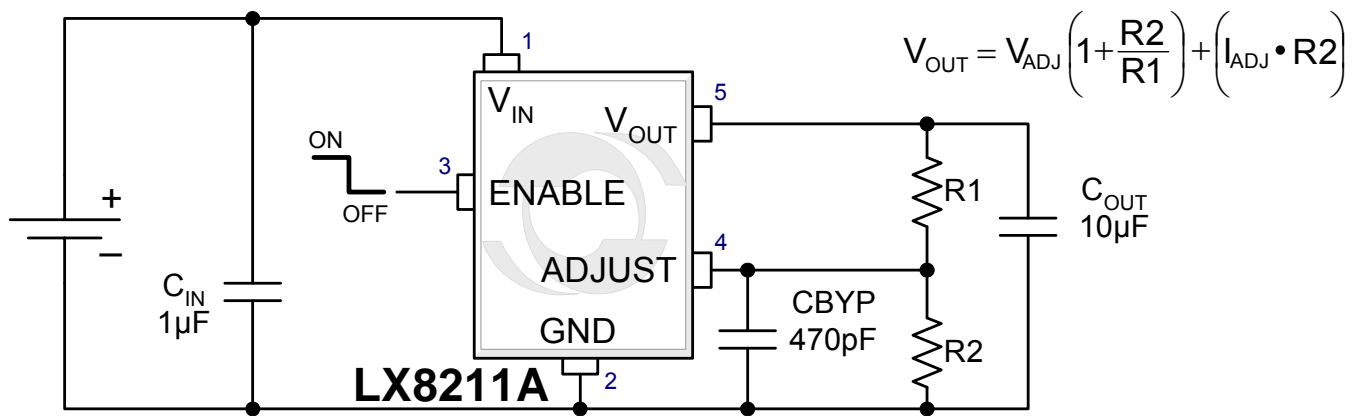
PRODUCT HIGHLIGHT

CBYP Optional for low noise

PACKAGE ORDER INFO

T _J (°C)	OUTPUT VOLTAGE	SE Plastic SOT-23 5-PIN RoHS Compliant / Pb-free	PACKAGE MARKING
-40 to 125	Adjustable	LX8211A-00ISE	E2C

Note: Available in Tape & Reel. Append the letters "TR" to the part number. (i.e. LX8211A-25ISE-TR)

ABSOLUTE MAXIMUM RATINGS

Input Voltage (V_{IN})	-0.3V to +15V
Enable Input	-0.3V to $V_{IN} + 0.3V$
Output Current (I_{OUT})	150mA
Maximum Junction Temperature (T_J)	150°C
Peak Package Solder Reflow Temperature (40 second max. exposure)	260°C (+0, -5)

Note: Exceeding these ratings could cause damage to the device. All voltages are with respect to Ground. Currents are positive into negative out of specified terminal.

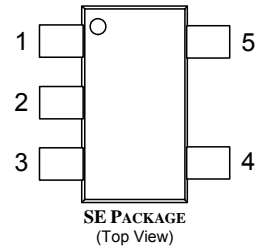
PACKAGE PIN OUT

RoHS / Pb-free 100% Matte Tin Lead Finish

THERMAL DATA
SE 5-PIN SOT-23 PACKAGE
Thermal Resistance – Junction to Ambient, θ_{JA}

■ Two – Layer Board	220°C/W
■ Four – Layer Board	220°C/W

Junction Temperature Calculation: $T_J = T_A + (P_D \times \theta_{JA})$.

The θ_{JA} numbers are guidelines for the thermal performance of the device/pc-board system. All of the above assume no ambient airflow.

FUNCTIONAL PIN DESCRIPTION

PIN NAME	PIN NUMBER	DESCRIPTION
VIN	1	Unregulated Input Supply Voltage
GND	2	Ground Pin
ENABLE	3	Enable Control Input, Enable High
ADJUST	4	Adjust Control Input for Resistor Divider Network.
VOUT	5	Regulated Output Voltage. Regulator stability is achieved with an external capacitor of 10 μ F.

RECOMMENDED OPERATING CONDITIONS

Parameter	Symbol	LX8211A			Units
		Min	Typ	Max	
Input Operating Voltage Range (Note 1)	V _{IN}	3.0		13.0	V
Minimum Output Voltage		2.3			V
Enable Input Voltage Range	ENABLE	0		V _{IN}	
Continuous Output Current Range	I _{OUT}	0.1		150	mA
Operating Temperature Range	T _J	-40		125	°C
Input Capacitor (V _{IN} to GND)	C _{IN}	1.0	1.0*		μF
Output Capacitor (V _{OUT} to GND)	C _{OUT}	10			μF

Note 1: The minimum V_{IN} has to meet two conditions V_{IN} ≥ 3.0V and V_{IN} ≥ V_{OUT} + V_{DROPOUT}.

* Size your output capacitor to meet the transient loading requirement. If you have a very dynamic load, a lower ESR and larger value capacitor will improve the response to these load steps.

ELECTRICAL CHARACTERISTICS

Unless otherwise specified, the following specifications apply over the operating ambient temperature -40°C ≤ T_J ≤ 125°C except where noted. Test conditions: V_{IN} = V_{OUT} + 1V, V_{OUT} = 2.9V; I_{OUT} = 10mA; C_{IN} = 1μF; C_{OUT} = 10μF; T_J = T_A, using low duty cycle pulse testing methods.

Parameter	Symbol	Test Conditions	LX8211A			Units
			Min	Typ	Max	
Adjust Reference Voltage	V _{ADJ}	Note 3	1.225	1.25	1.275	V
Line Regulation $\left(\frac{\Delta V_O}{\Delta V_{IN}}\right)$	V _{RV}	V _{IN} = V _{OUT} + 1.0 TO 13 Volts, I _{OUT} = 0.1mA		0.04	0.1	%/V
Load Regulation $\left(\frac{\Delta V_O}{\Delta I_O}\right)$	V _{RI}	T _J = 25°C, I _{OUT} : 0.5 TO 150mA		0.05	0.2	%V _{NOM}
		I _{OUT} : 0.5 TO 150mA			0.5	%V _{NOM}
Dropout Voltage (V _{IN} - V _O) (Note2)	V _{DO}	I _{LOAD} = 10mA, ΔV _O = -1%			0.1	V
		I _{LOAD} = 50mA, ΔV _O = -1%		0.12	0.23	V
		I _{LOAD} = 100mA, ΔV _O = -1%		0.175	0.3	V
		I _{LOAD} = 150mA, ΔV _O = -1%		0.25	0.35	V
Ground Pin Current	I _{GND}	Enable = Hi, I _{OUT} = 100mA		600	1500	μA
		Enable = Hi, I _{OUT} = 150mA		1300	2500	μA
		Enable = Low (Standby)			5	μA
Adjust Input Bias Current	I _{ADJ}	Current Flows Out of Pin 4		50	500	nA
Enable Pin Current	I _{EN}	V _{EN} = V _{IN}			25	μA
Enable Threshold	V _{IH}		2.0			V
	V _{IL}				0.18	V
Short Circuit Current Limit	I _{OUTSC}	V _{OUT} = 0V		400		mA
Power Supply Rejection Ratio	PSRR	T _J = 25°C, f = 120Hz		75		dB
Output Noise	e _N	T _J = 25°C, C _{OUT} = 10μF		260		nv/√Hz
Thermal Shutdown Temperature	T _{SD}			170		°C

Note 2: Dropout voltage is defined as the input to output differential at which the output voltage drops 1% below the nominal value.

Note 3: Limits require operation within recommended operating conditions.

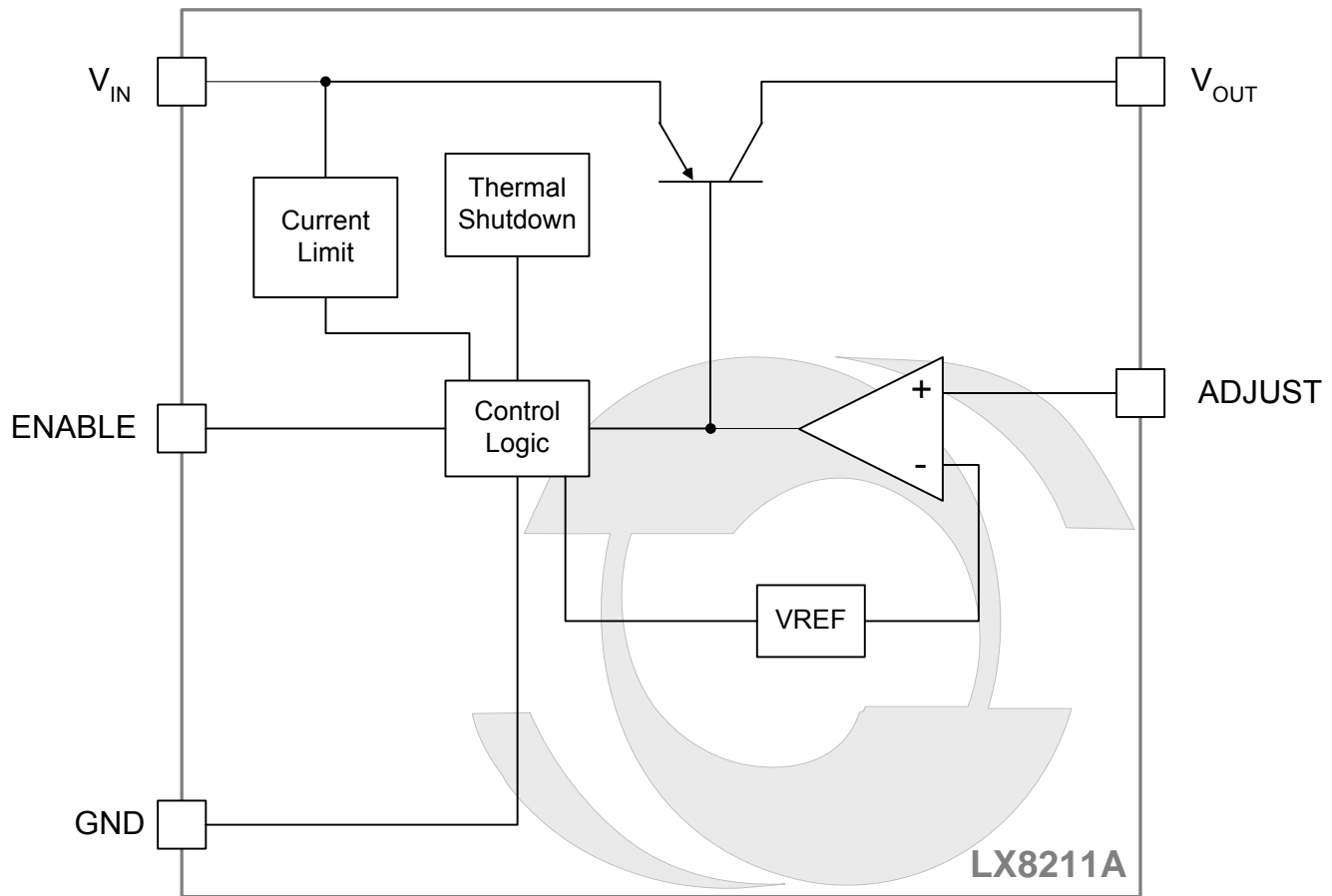
BLOCK DIAGRAM

Figure 1 – Simplified Adjustable Version Block Diagram

TYPICAL CHARACTERISTICS

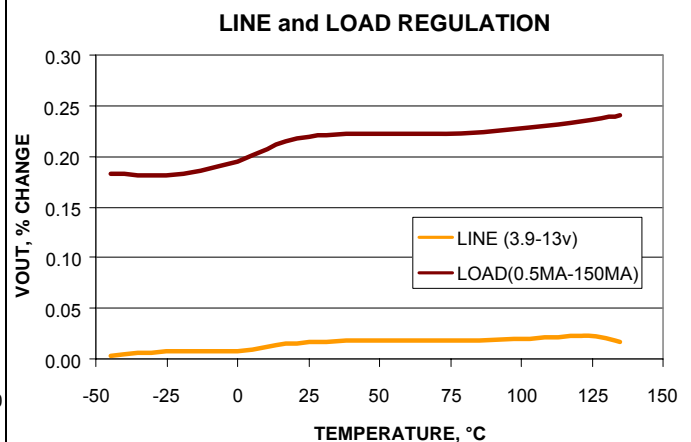
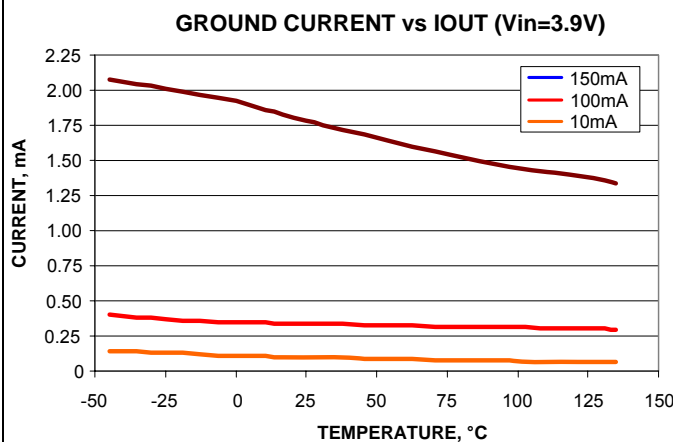
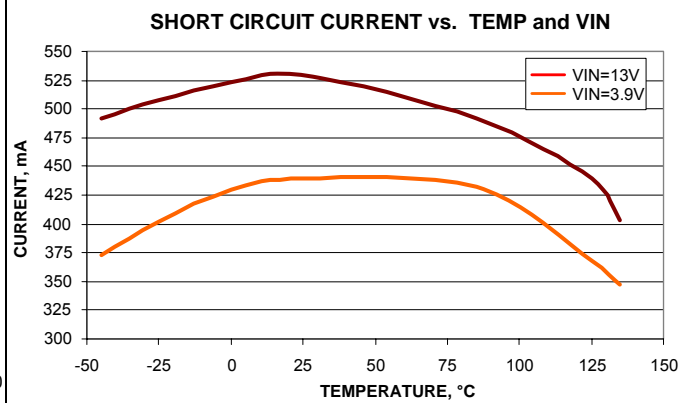
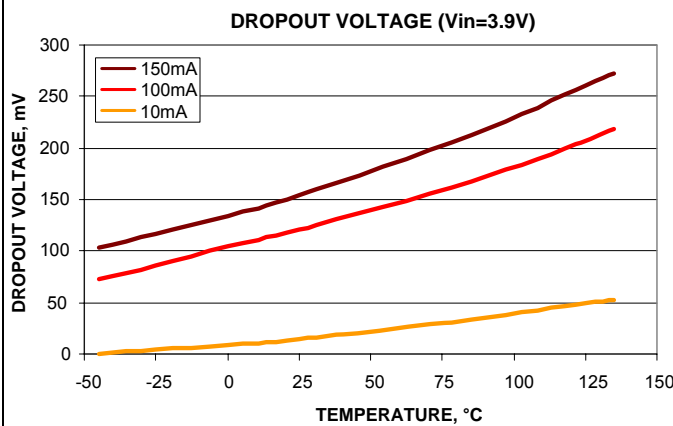
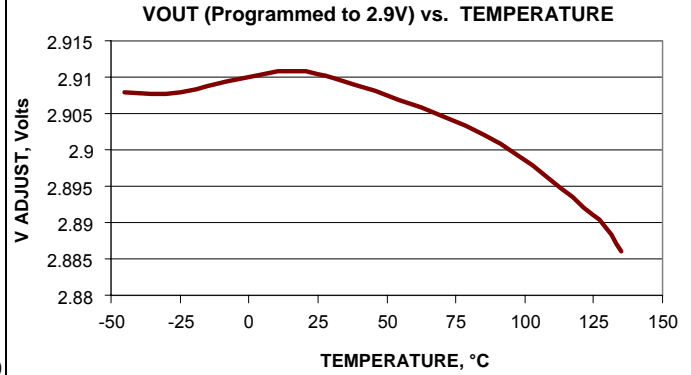
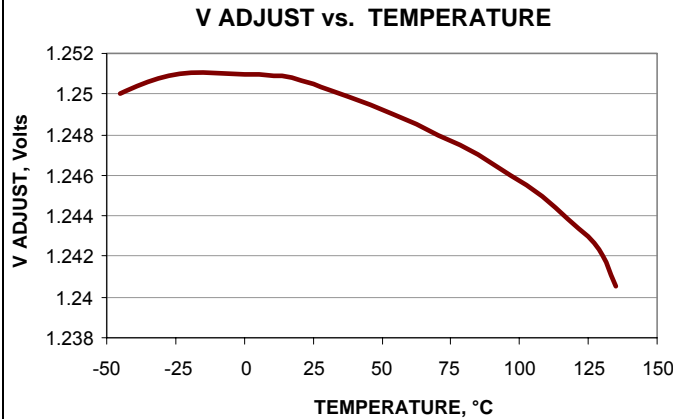
Typical performance characteristics, unless otherwise specified are: $C_{IN} = 1\mu F$, $C_{OUT} = 10\mu F$, $C_{BY} = 470pF$, $V_{IN} = 4V$, $V_{OUT} = 2.9V$, $T_A = 25^\circ C$, ENABLE is tied to V_{IN} .



TYPICAL CHARACTERISTICS (CONTINUED)

Typical performance characteristics, unless otherwise specified are: $C_{IN} = 1\mu\text{F}$, $C_{OUT} = 10\mu\text{F}$, $C_{BY} = 470\text{pF}$, $V_{IN} = 4\text{V}$, $V_{OUT} = 2.9\text{V}$, $T_A = 25^\circ\text{C}$, ENABLE is tied to V_{IN} .

Power Supply Rejection vs. Frequency
10MA LOAD $C_{BYPASS} = 470\text{PF}$

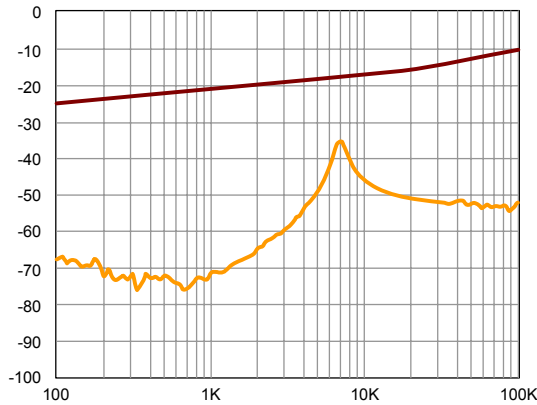

Enable Response

$V_{IN} = 4\text{V}$, $C_{IN} = 1\mu\text{F}$, $C_{OUT} = 10\mu\text{F}$, $C_{BYP} = 470\text{pF}$, $I_{OUT} = 100\text{mA}$.
CH2 = $V_{OUT} = 2.9\text{V}$. CH1 - V_{ENABLE}

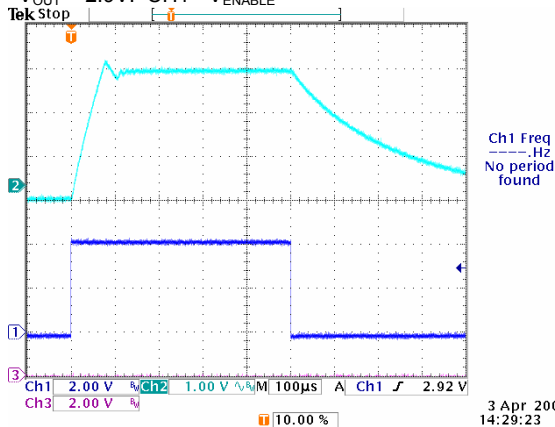

Line Regulation Step Response

$V_{IN} = 4\text{V}$, $C_{IN} = 1\mu\text{F}$, $C_{OUT} = 10\mu\text{F}$, $C_{BYP} = 470\text{pF}$, $I_{OUT} = 100\text{mA}$.
CH2 = $V_{OUT} = 2.9\text{V}$. CH1 = V_{IN} from 3.5V to 4.5V

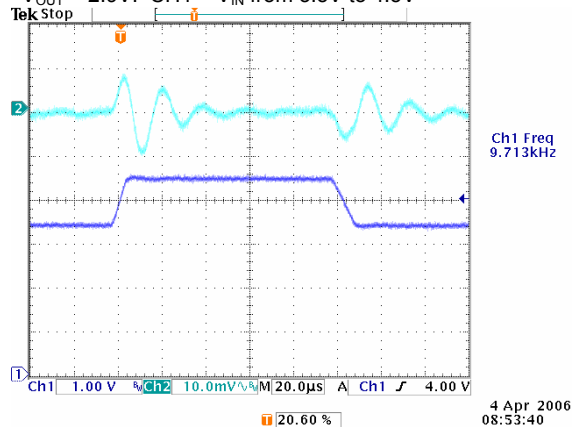

Load Transient Response

$V_{IN} = 4\text{V}$, $C_{IN} = 1\mu\text{F}$, $C_{OUT} = 10\mu\text{F}$, $C_{BYP} = 470\text{pF}$, $I_{OUT} = 50\text{mA}$.
CH2 = $V_{OUT} = 2.9\text{V}$. CH4 = $I_{STEP} = 20\text{mA}$ to 70mA

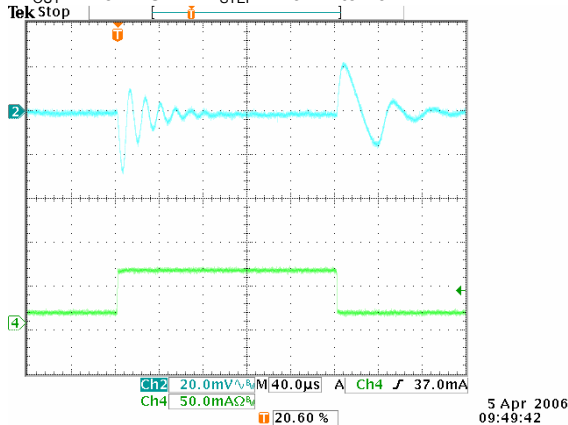

Load Transient Response

$V_{IN} = 4\text{V}$, $C_{IN} = 1\mu\text{F}$, $C_{OUT} = 10\mu\text{F}$, $C_{BYP} = 470\text{pF}$, STEP Load = 100mA .
CH2 = $V_{OUT} = 2.9\text{V}$. CH4 = $I_{STEP} = 20\text{mA}$ to 100mA

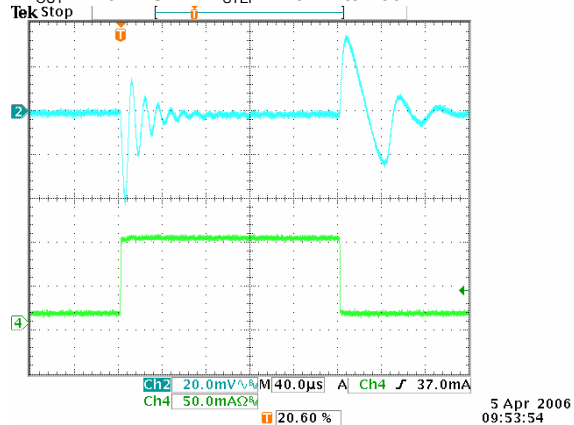

APPLICATION INFORMATION**Description**

The LX8211A is a family of LDO (Low Dropout) linear regulators in a small SOT-23 Package, which provides a compact and cost effective solution. The family includes several fixed output voltages, along with an adjustable version. The internal PNP power device provides low dropout regulation with fast line and load transient response. It also includes internal current limit and thermal shutdown circuitry. This section contains information about the selection of external capacitors, thermal, and layout consideration.

Input Capacitor

To improve load transient response and noise rejection a bypass capacitor is recommended, but it is not required for stability. There are no requirements for the ESR (Equivalent Series Resistor) on the input capacitor, but tolerance and temperature coefficient must be considered when selecting the capacitor to ensure the capacitor will be around 1 μ F over the entire operating temperature range. For the LX8211A connect a ceramic type capacitor (1 μ F) between V_{IN} and ground.

Output Capacitor

To maintain a constant output voltage a feedback loop is necessary. The feedback loop causes a well known a phase shift, the amount of phase shift determines the loop stability. Therefore the LX8211A, like any low dropout regulator, requires an output capacitor with low ESR (Equivalent Series Resistor) connected between V_{OUT} and GND to stabilize the internal control loop. For the LX8211A a ceramic, tantalum, or electrolytic capacitor with the minimum recommended capacitance value at 10 μ F with ESR between 5m Ω and 1 Ω will satisfy the stability for whole operating range.

Adjustable Output Voltage

The LX8211A-00 adjustable regulator's output voltage can be externally set by connecting the ADJ pin to an external resistor divider (See Figure 1). The output voltage can be calculated using:

$$V_{OUT} = 1.25 \left[1 + \frac{R2}{R1} \right] + [I_{ADJ} \cdot R2]$$

Enable

The Enable pin allows the LX8211A to be turned on and off. The Enable pin is compatible with standard TTL-CMOS levels. A logic zero (0.4V) on the Enable pin shuts the LX8211A off and reduces the supply current to less than 1 μ A. Pulling the Enable input high (2.0V) causes normal operation to resume. If the Enable feature is not used, this pin can be connected to V_{IN}.

Minimum Load Requirement

The LX8211A is stable even at zero load; no minimum load is required for operation, which is especially important in keep-alive applications. However line regulation is improved with a minimum load of 100 μ A.

Temperature Protection

Thermal protection shuts the LX8211A down when the junction temperature exceeds approximately 150°C; there is no appreciable thermal hysteresis.

Short Circuit Current Protection

The LX8211A includes over current protection, when the output load current exceeds typically 400mA the circuit forces the regulator to decrease in output.

Thermal Consideration

Thermal shutdown protects the integrated circuit from thermal overload caused from a rise in junction temperature during power dissipation. This means of protection is intended for fault protection only and not as a means of current or power limiting during normal application usage. Proper thermal evaluation should be done to ensure that the junction temperature does not exceed its maximum rating. Operating at the maximum T_J of 150°C can impact reliability. Due to variation in individual device electrical characteristics and thermal resistance, the built in thermal overload protection may be activated at power levels slightly above or below the rated dissipation.

Power dissipation for regulator can be calculated using the following equation:

$$P_D = (V_{IN(MAX)} - V_{OUT(MIN)}) * I_{OUT(MAX)}$$

(Note: power dissipation resulting from quiescent current is negligible)

For the SOT23 package, thermal resistance, θ_{JA} is 220°C/W when mounted on a FR4 copper clad PCB. Junction temperature of the integrated circuit can be calculated using:

$$T_J = T_A + T_{RISE}, \text{ substituting: } T_A + (P_D * \theta_{JA}).$$

An example:

Given conditions: T_A = 60°C, V_{IN} = 4.2V, V_{OUT} = 2.7V, I_{OUT} = 100mA.

Calculated values:

$$\text{Total Power dissipation } P_{D(\text{total})} = (4.2 - 2.7) \text{ V} * 0.1 \text{ A} = 0.15 \text{ W}$$

$$\text{Junction Temperature } T_J = 60^\circ\text{C} + (0.15 \text{ W} * 220^\circ\text{C/W}) = 93^\circ\text{C}$$

Layout Consideration:

The layout must be done with low impedance paths for V_{IN}, V_{OUT}, and Ground by applying sufficient wide traces to avoid voltage drops and pick up noise. Adding an area of PCB copper to the GND pin (pin2) will reduce the overall θ_{JA} since it is thermally connected to the device substrate. This will lower the device junction temperature improving the overall output accuracy. The input / output capacitors must be placed as close as possible to the voltage regulator output pin. To allow the same voltage reference for all circuits, use a star configuration from the output capacitor to the different loads.

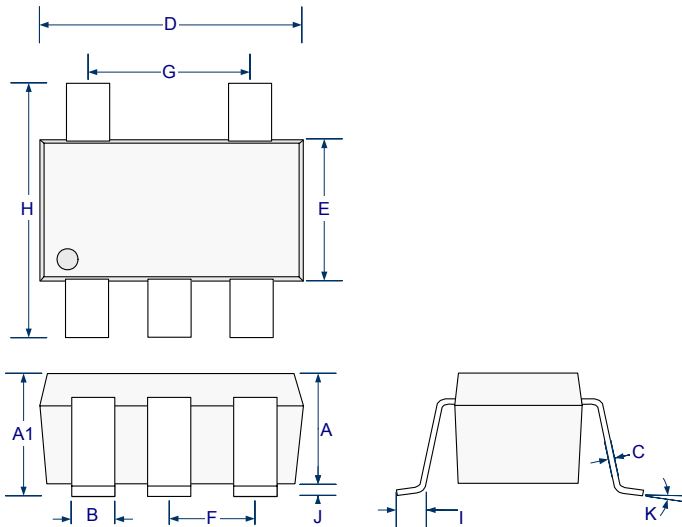
PACKAGE DIMENSION
SE 5 Pin Plastic SOT-23

Dim	MILLIMETERS		INCHES	
	MIN	MAX	MIN	MAX
A	0.90	1.30	0.035	0.051
A1	0.90	1.45	0.035	0.057
B	0.25	0.50	0.010	0.020
C	0.09	0.20	0.004	0.008
D	2.80	3.10	0.110	0.122
E	1.50	1.75	0.059	0.069
F	0.95 BSC		0.038 BSC	
G	1.90 BSC		0.075 BSC	
H	2.60	3.00	0.102	0.118
I	0.35	0.55	0.014	0.022
J	0.00	0.15	0.000	0.006
K	10° MAX		10° MAX	

Note:

- Dimensions do not include mold flash or protrusions; these shall not exceed 0.155mm(.006") on any side. Lead dimension shall not include solder coverage.



Microsemi[®]

LX8211A

150mA Low Dropout Regulator

PRODUCTION DATA SHEET

NOTES

PRODUCTION DATA – Information contained in this document is proprietary to Microsemi and is current as of publication date. This document may not be modified in any way without the express written consent of Microsemi. Product processing does not necessarily include testing of all parameters. Microsemi reserves the right to change the configuration and performance of the product and to discontinue product at any time.