**LOW RIPPLE VOLTAGE
REGULATOR WITH EXTERNAL
TRANSISTOR**

RN5RF SERIES

APPLICATION MANUAL

RN5RF SERIES

OUTLINE

The RN5RF Series are voltage regulator ICs which control external driver transistors with high ripple rejection, high accuracy output voltage, low supply current by CMOS process. Each of these voltage regulator ICs consists of a voltage reference unit, an error amplifier, output voltage setting resistor, short circuit current limiting circuit and chip enable circuit. These ICs are suitable for constructing regulators with ultra low dropout voltage and an output current in the range of several tens of mA and several hundreds mA. In addition to low supply current by CMOS process, chip enable function can be used to conserve battery life during standby.

Furthermore, a supreme ripple rejection and a transient response are suited for portable communication such as cell phones, PDAs, walky talkies. SOT23-5 (Mini Mold) package is available.

FEATURES

- Ultra Low Supply CurrentTYP. $30\mu\text{A}$
- Standby ModeTYP. $0.1\mu\text{A}$
- High Accuracy Output Voltage $\pm 2.0\%$
- High Ripple RejectionTYP. $60\text{dB}/f=1\text{kHz}$
- Low Dropout VoltageTYP. $0.1\text{V}/I_{\text{OUT}}=100\text{mA}$, dependent on External Tr.
- Low Temperature DriftTYP. $\pm 100\text{ppm}/^\circ\text{C}$
- High Line RegulationTYP. $0.05\%/V$
- Output Voltage.....Stepwise setting with a step of 0.1V in the range of 1.8V to 6.0V
- Current Limit for external TrTYP. 8mA , Limit a base current

APPLICATIONS

- Power source for battery-powered equipment
- Telecommunications, Cameras, VCRs
- Power source for domestic appliances

BLOCK DIAGRAM

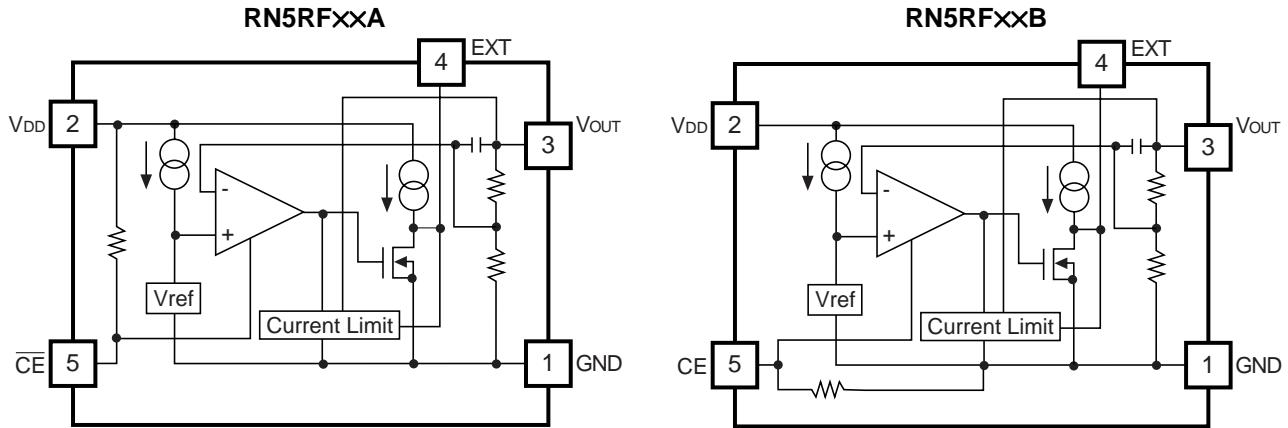

SELECTION GUIDE

The output voltage, the chip enable active type, the packing type and the taping type for the ICs can be selected at the user's request.

The selection can be made by designating the part number as shown below:

RN5RF xxxx-xx ← Part Number
 ↑ ↑ ↑ ↑
 a b c d

Code	Contents
a	Setting Output Voltage (V _{OUT}) : Stepwise setting with a step of 0.1V in the range of 1.8V to 6.0V is possible.
b	Designation of Chip enable Active Type A: "L" active type B: "H" active type
c	Designation of Packing type A: Taping C: Antistatic bag only for samples
d	Designation of Taping type Ex. TR, TL (refer to Taping Specifications, TR type is prescribed as a standard.)

PIN CONFIGURATION

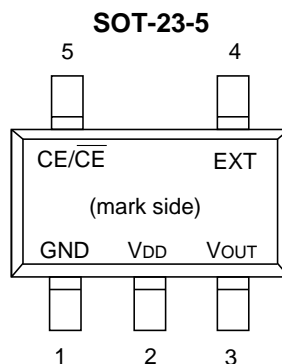

PIN DESCRIPTION

Pin No.	Symbol	Pin Description
1	GND	Ground Pin
2	V _{DD}	Input Pin
3	V _{OUT}	Output Pin
4	EXT	External Transistor Drive Pin (CMOS Output)
5	CE or $\overline{\text{CE}}$	Chip Enable Pin

ABSOLUTE MAXIMUM RATINGS

Symbol	Item	Rating	Unit
V _{IN}	Input Voltage	12	V
V _{CE}	Input Voltage for CE/ $\overline{\text{CE}}$ Pin	-0.3 to V _{IN} + 0.3	V
V _{EXT}	EXT Output Voltage	12	V
I _{EXT}	EXT Output Current	50	mA
P _D	Power Dissipation	150	mW
T _{opt}	Operating Temperature Range	-40 to +85	°C
T _{stg}	Storage Temperature Range	-55 to +125	°C

ABSOLUTE MAXIMUM RATINGS

Absolute Maximum ratings are threshold limit values that must not be exceeded even for an instant under any conditions. Moreover, such values for any two items must not be reached simultaneously. Operation above these absolute maximum ratings may cause degradation or permanent damage to the device. These are stress ratings only and do not necessarily imply functional operation below these limits.

ELECTRICAL CHARACTERISTICS

T_{opt}=25°C

Symbol	Item	Conditions	MIN.	TYP.	MAX.	Unit
V _{OUT}	Output Voltage	V _{IN} -V _{OUT} =1.0V I _{OUT} =50mA	V _{OUT} ×0.98		V _{OUT} ×1.02	V
I _{OUT}	Output Current	V _{IN} -V _{OUT} =1.0V		1.0 ^{*1}		A
I _{EXT}	EXT Current	V _{IN} =4.0V, V _{EXT} =2.0V	5	8	15	mA
ΔV _{OUT} /ΔI _{OUT}	Load Regulation	V _{IN} -V _{OUT} =1.0V 1mA≤I _{OUT} ≤100mA	-60		60	mV
V _{DIF}	Dropout Voltage	I _{OUT} =100mA, I _{OUT} =0mA		0.1	0.2	V
I _{SS}	Supply Current	V _{IN} -V _{OUT} =1.0V		30	50	μA
I _{standby}	Standby Current	V _{IN} =10.0V	0.01	0.1	1.0	μA
I _{EXTleak}	EXT Leakage Current				0.5	μA
ΔV _{OUT} /ΔV _{IN}	Line Regulation	I _{OUT} =50mA V _{OUT} +0.5V≤V _{IN} ≤10V	0	0.05	0.30	%/V
R _R	Ripple Rejection	f=1kHz, sinusoidal 0.5Vp-p V _{IN} -V _{OUT} =1.0V		60		dB
V _{IN}	Input Voltage				10	V
V _{EXT}	EXT Output Voltage				10	V
ΔV _{OUT} /ΔT _{opt}	Output Voltage Temperature Coefficient	I _{OUT} =10mA -40°C≤T _{opt} ≤85°C		±100		ppm/°C
R _{PU}	Pull up resistance for CE pin			4		MΩ
V _{CEH}	CE Input Voltage "H"		1.5		V _{IN}	V
V _{CEL}	CE Input Voltage "L"		0		0.25	V

*1) The output current depends on the performance of external PNP transistor. Use External PNP transistor of a low saturation type, with an h_{FE} between 100 and 300.

*) With respect to Test Circuit, refer to Typical Application.

T_{opt}=25°C

Symbol	Item	Conditions	MIN.	TYP.	MAX.	Unit
V _{OUT}	Output Voltage	V _{IN} -V _{OUT} =1.0V I _{OUT} =50mA	V _{OUT} ×0.98		V _{OUT} ×1.02	V
I _{OUT}	Output Current	V _{IN} -V _{OUT} =1.0V		1.0*1		A
I _{EXT}	EXT Current	V _{IN} =4.0V, V _{EXT} =2.0V	5	8	15	mA
ΔV _{OUT} /ΔI _{OUT}	Load Regulation	V _{IN} -V _{OUT} =1.0V 1mA≤I _{OUT} ≤100mA	-60		60	mV
V _{DIF}	Dropout Voltage	I _{OUT} =100mA		0.1	0.2	V
I _{SS}	Supply Current	V _{IN} -V _{OUT} =1.0V I _{OUT} =0mA		30	50	μA
I _{standby}	Standby Current	V _{IN} =10.0V	0.01	0.1	1.0	μA
I _{EXTleak}	EXT Leakage Current				0.5	μA
ΔV _{OUT} /ΔV _{IN}	Line Regulation	I _{OUT} =50mA V _{OUT} +0.5V≤V _{IN} ≤10V	0	0.05	0.30	%/V
R _R	Ripple Rejection	f=1kHz, sinusoidal 0.5Vp-p V _{IN} -V _{OUT} =1.0V		60		dB
V _{IN}	Input Voltage				10	V
V _{EXT}	EXT Output Voltage				10	V
ΔV _{OUT} /ΔT _{opt}	Output Voltage Temperature Coefficient	I _{OUT} =10mA -40°C≤T _{opt} ≤85°C		±100		ppm/°C
R _{PD}	Pull down resistance for CE pin			4		MΩ
V _{CEH}	CE Input Voltage “H”		1.5		V _{IN}	V
V _{CEL}	CE Input Voltage “L”		0		0.25	V

*1) The output current depends on the performance of external PNP transistor. Use External PNP transistor of a low saturation type, with an h_{FE} between 100 and 300.

*) With respect to Test Circuit, refer to Typical Application.

OPERATION

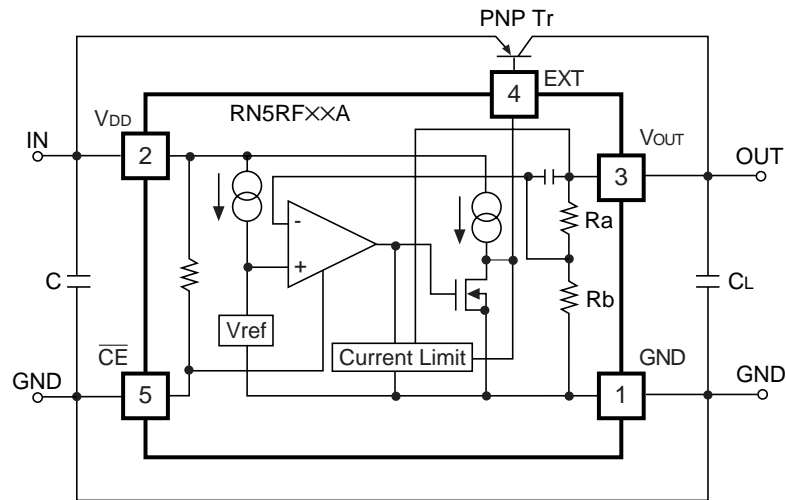

In these ICs, Output Voltage V_{OUT} is detected by Feed-back Resistors, R_A and R_B and the detected Output Voltage is compared with a reference voltage by Error Amplifier so that the base current of External PNP Transistor can be adjusted and Output Voltage V_{OUT} is able to be regulated.

The base current of an external Tr. is monitored and controlled by an internal Base Current Limit circuit to keep current within a proper range. Furthermore, the other current limit circuit prevents a problem which is that a base current increases sharply when input Voltage V_{IN} becomes lower than Set Output Voltage.

Notes on selecting external components

- (1) On external PNP transistor
Be careful of output current, input voltage and power dissipation of External PNP Transistor.
External PNP Transistor with a low $V_{CE(sat)}$ and an h_{FE} between 100 and 300 is suitable.
- (2) On phase compensation In these ICs, phase compensation is made for securing stable operation on the output stage even if the load current is varied. For this purpose, be sure to use a capacitor C_L (tantalum type) with a capacitance of $10\mu F$ or more. There may be the case the loop oscillation takes place when a tantalum capacitor C_L with a large ESR is used, so select the C_L carefully including the frequency characteristics.

TEST CIRCUITS

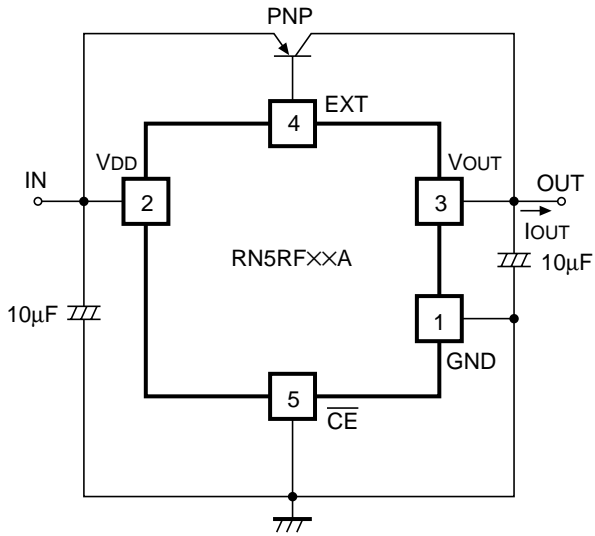

Basic Test Circuit

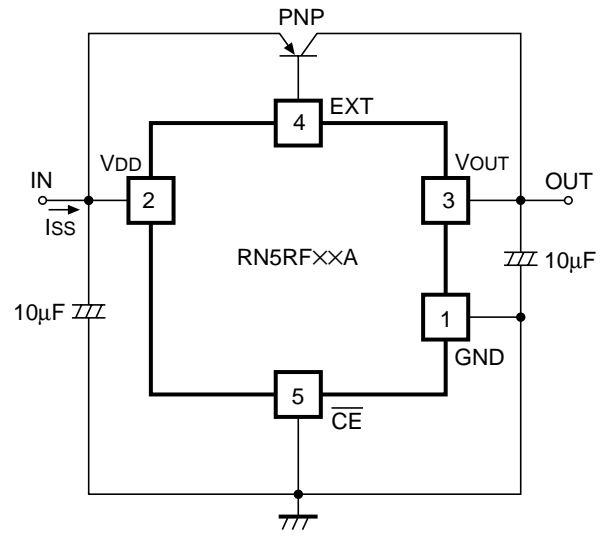

Test Circuit for Supply Current

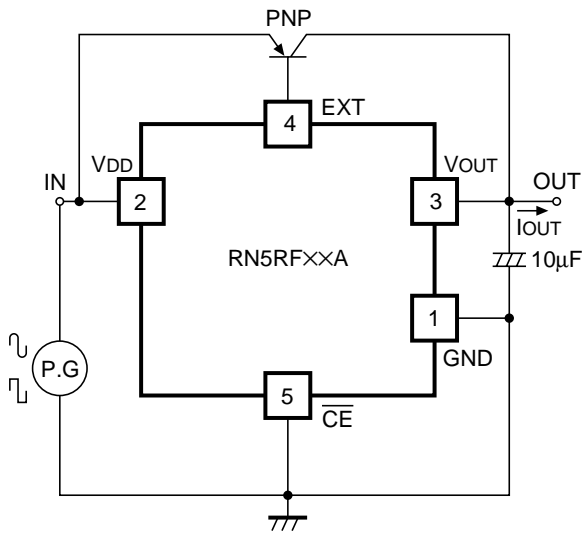

Test Circuit for Ripple Rejection and Line Transient Response

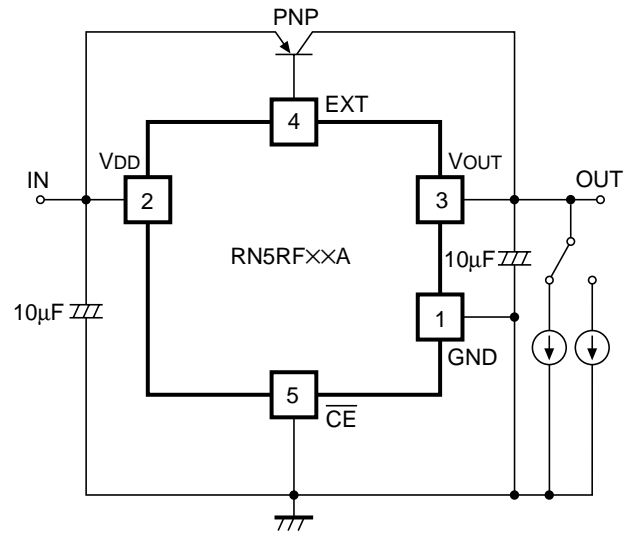

Test Circuit for Load Transient Response

TYPICAL CHARACTERISTICS

1) Output Voltage vs. Input Voltage (T_{opt}=25°C)

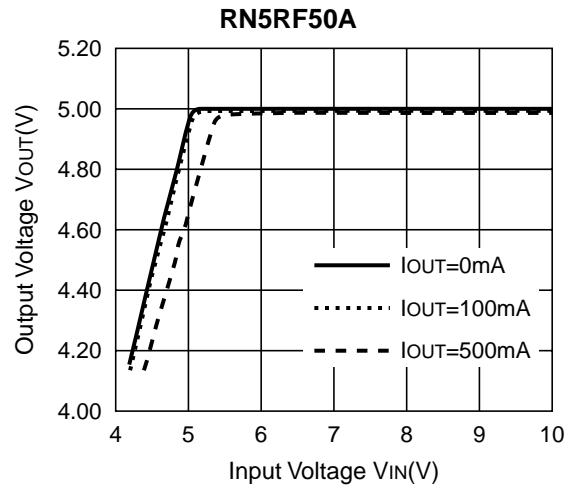
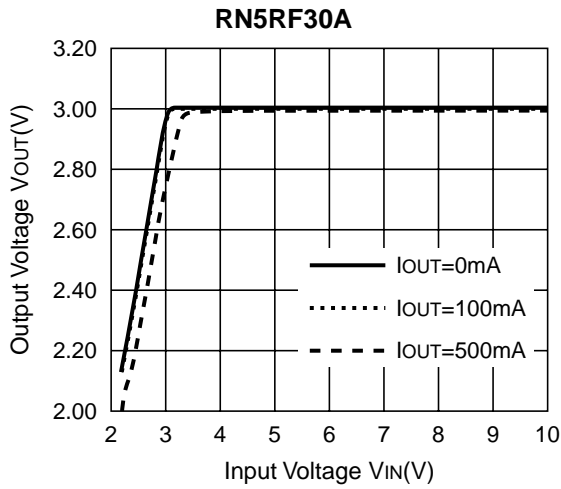

2) Output Voltage vs. Output Current (T_{opt}=25°C)

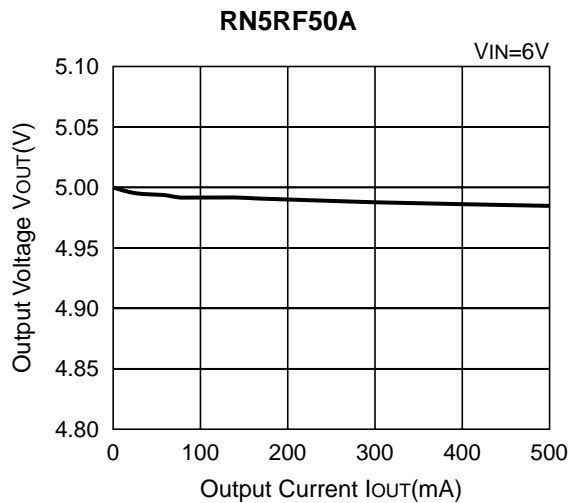
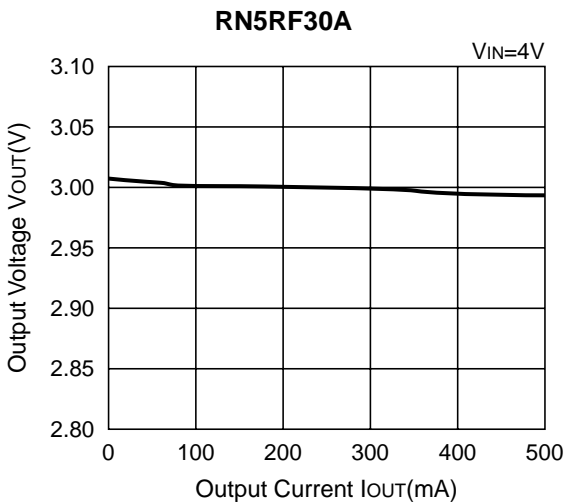

3) Dropout Voltage vs. Output Current

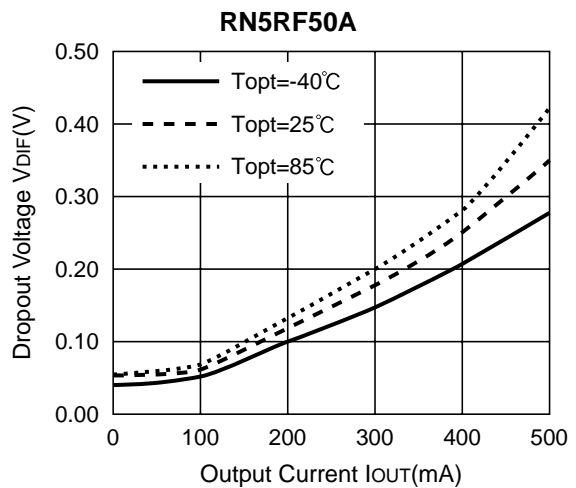
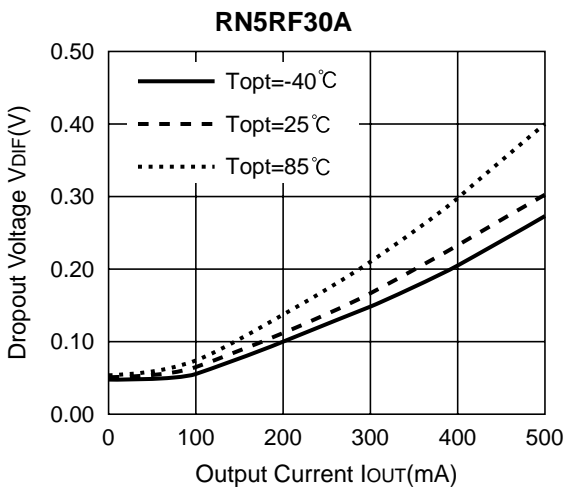

4) Output Voltage vs. Temperature

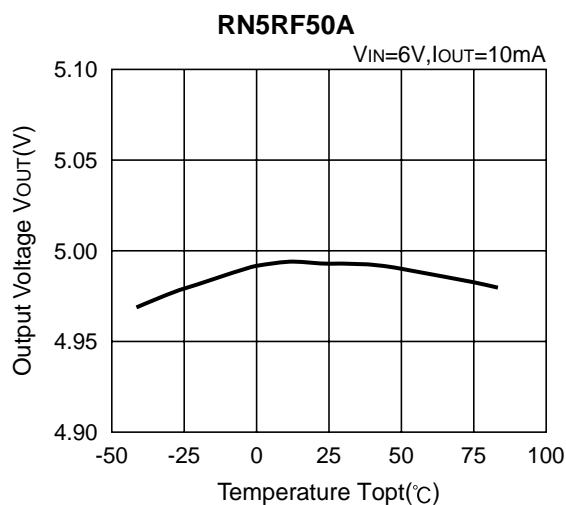
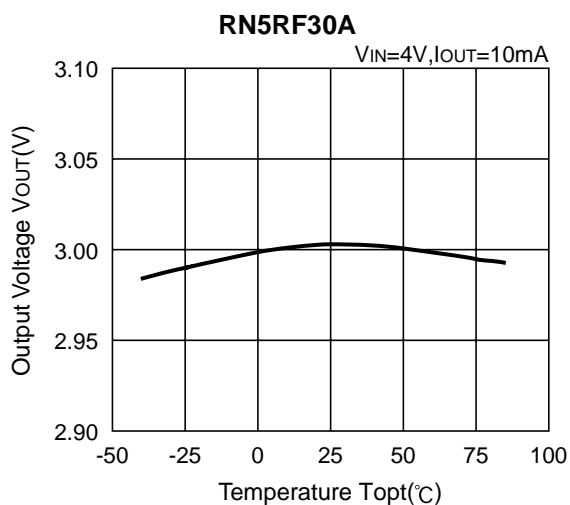

5) Supply Current vs. Input Voltage (T_{opt}=25°C)

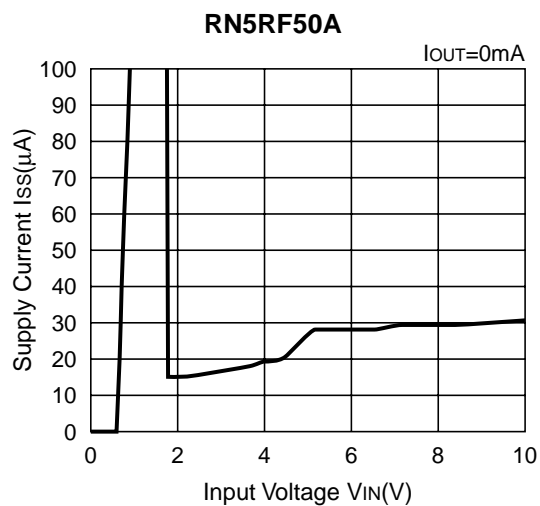
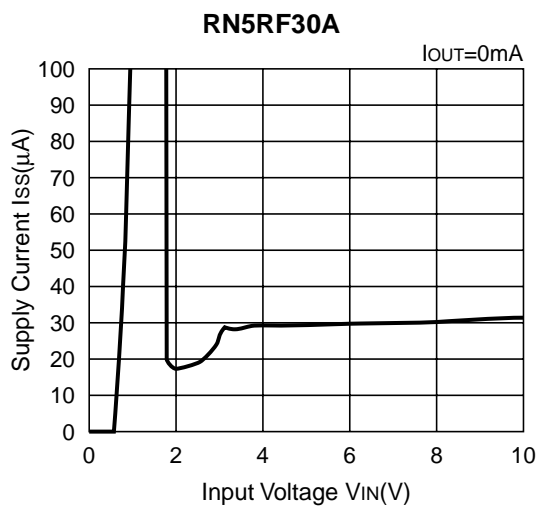

6) Supply Current vs. Temperature

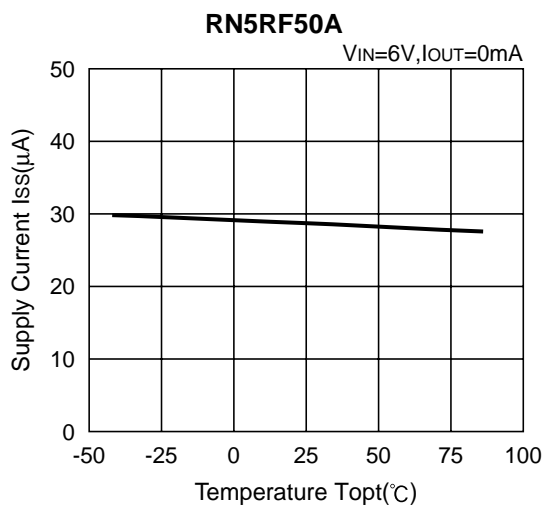
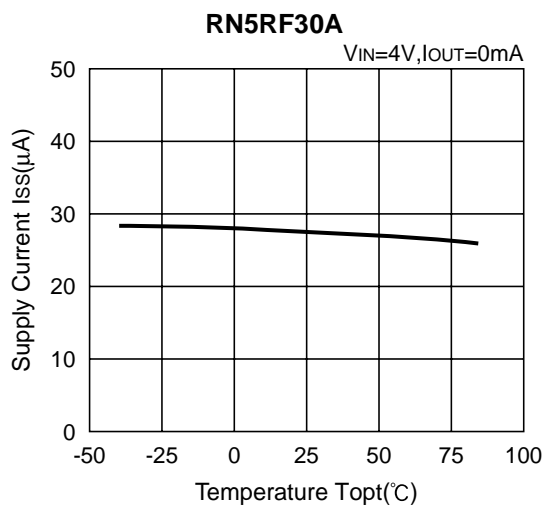

7) Ripple Rejection vs. Frequency (Topt=25°C)

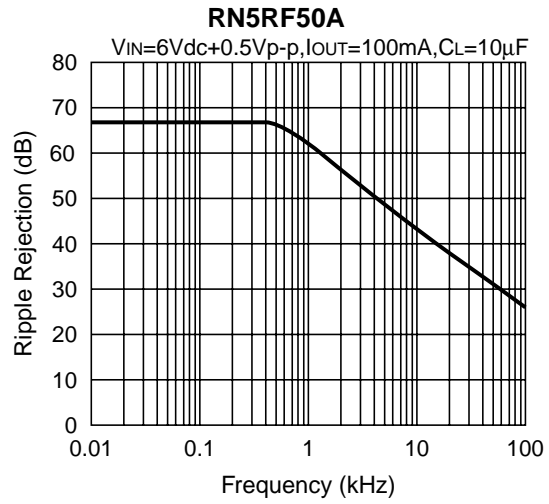
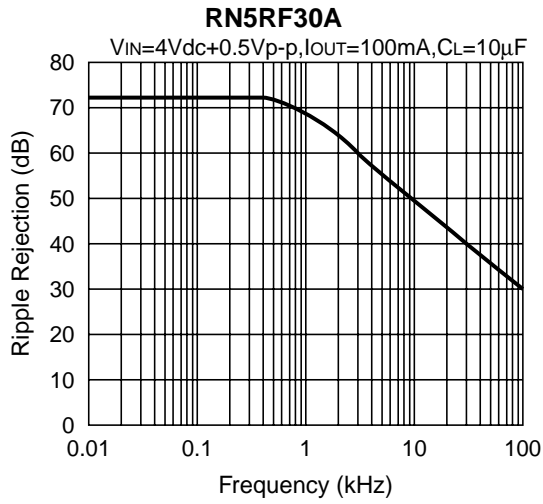

8) Line Transient Response (Topt=25°C)

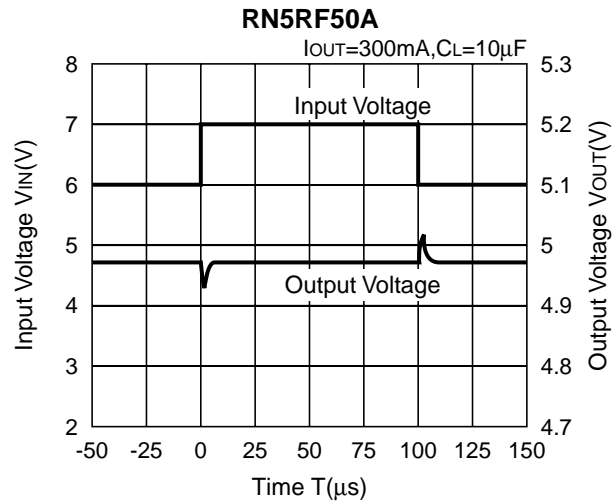
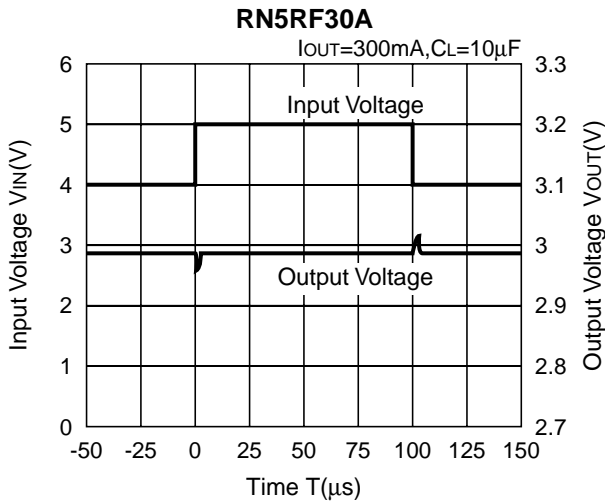

9) Load Transient Response (Topt=25°C)

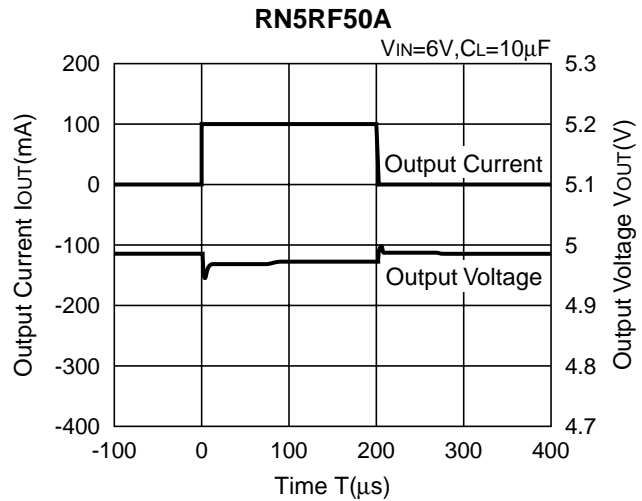
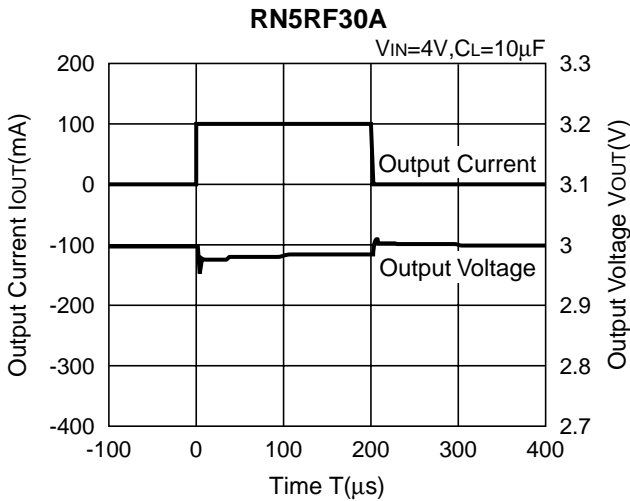

TYPICAL APPLICATION

