

DESCRIPTION

The ST1938 is a step-up DC/DC converter for white LED driver with over voltage protection. The device can driver one to four LEDs in series from a single cell Lithium Ion battery. Internal functions include current limiting; thermal shutdown; OVP and soft-start to prevent damage operate status. The ST1938 operates at 0.8MHz and from low input voltages as low as 1.5V; apply to Lithium-Ion powered systems. A low 95mV reference voltage minimizes power loss in the current setting resistor for better efficiency. The ST1938 is available in small package SOT-23-6L

PIN CONFIGURATION

SOT23-6L

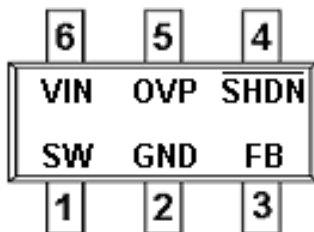

PART MARKING

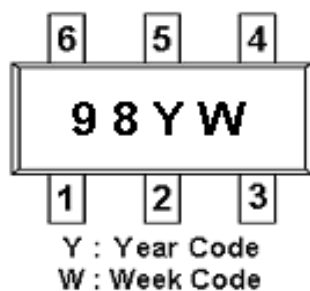

APPLICATIONS

- Battery Power Equipment
- Notebook Computers
- PDA
- Cellular Phone

FEATURES

- Current Source with Over Voltage Protection
- Fast 0.8MHz Switching Frequency
- High Efficiency up to 87%
- Drives up to Four LEDs From 3.2V Supply
- Drives up to Six LEDs From a 5V Supply
- Low Quiescent Current
- Disconnects LEDs in Shutdown Mode
- Internal Over Temperature and Current Limiting Shutdown Function
- Internal Soft-Start Circuit
- 36V Rugged Bipolar Switch
- Available in a Small SOT-23-6L Package

ORDERING INFORMATION

Part Number	Package	Part Marking
ST1938S26RG	SOT-23-6L	98YW

- ※ Week Code : A ~ Z (1 ~ 26) ; a ~ z (27 ~ 52)
- ※ ST1938S26RG : S25 : SOT-23-6 ; R : Tape Reel ; G : Pb - Free

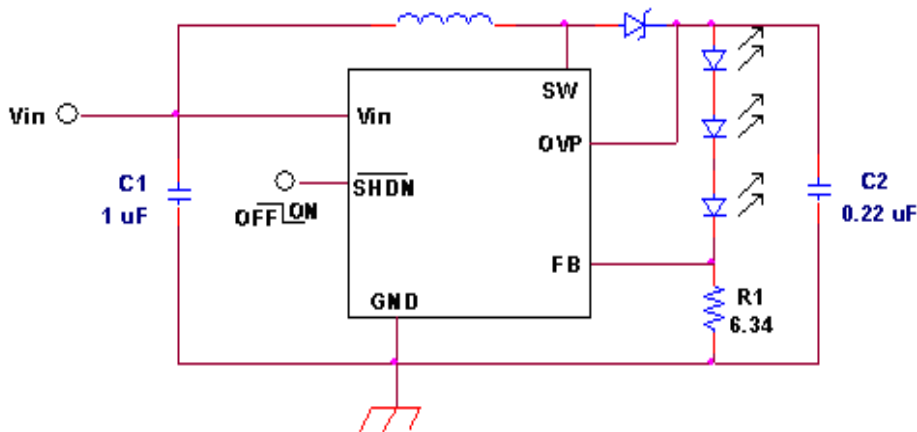
TYPICAL APPLICATION CIRCUIT

PIN DESCRIPTION
ST1938S26RG

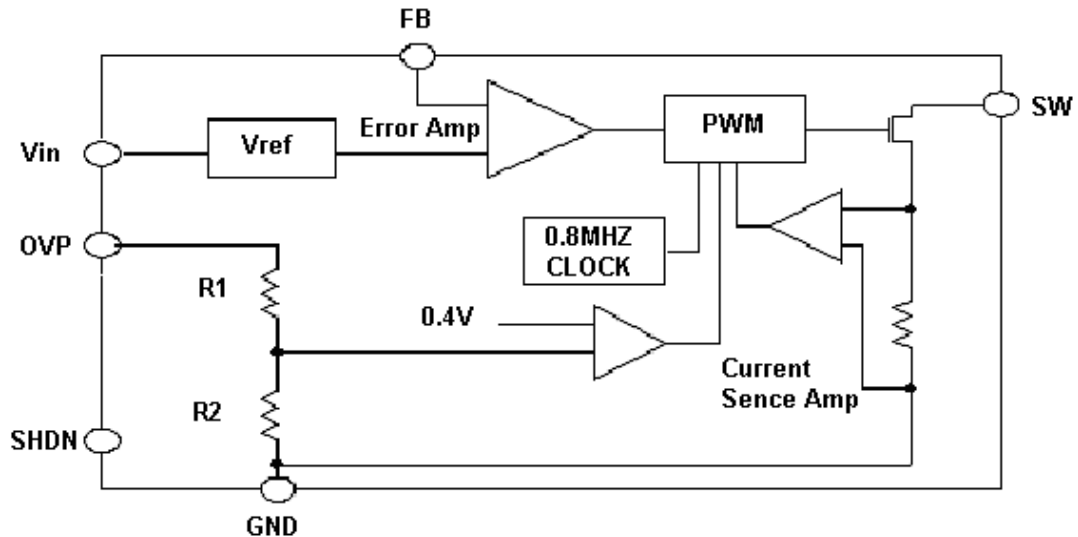
Pin	Symbol	Description
1	SW	Switch Pin.
2	GND	Ground Pin
3	FB	Feedback Pin.
4	SHDN	Shutdown Pin. Active-low enable and PWM control pin for LED dimming
5	VIN	Supply Voltage Input
6	OVP	Over voltage Protection and Connect to the output capacitor of the Converter

BLOCK DIAGRAM

ABSOLUTE MAXIMUM RATINGS (TA=25°C unless otherwise specified)

Symbol	Parameter	Value	Unit
VIN	DC Supply Voltage	7	V
VSW	SW Voltage	36	V
VFB	FB Voltage	7	V
VSHDN	SHDN Voltage	7	V
TOPR	Operating Temperature	-40~85	°C
TJ(Max)	Maximum Junction Temperature	125	°C
TS	Storage Temperature	-65~150	°C

The IC has a protection circuit against static electricity. Do not apply high static electricity or high voltage that exceeds the performance of the protection circuit to the IC.

ELECTRICAL CHARACTERISTICS (Ta=25°C, VIN=3.6V, unless otherwise specified.)

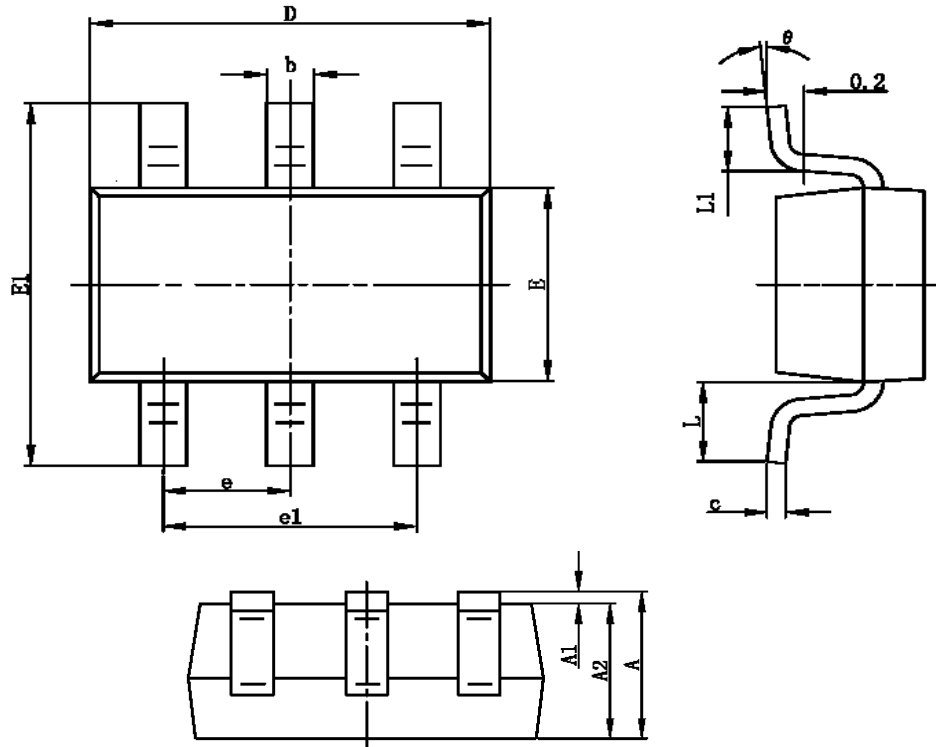
Symbol	Parameter	Conditions	Min.	Typ.	Max.	Unit
VIN	Operating Voltage		2.4		7	V
VFB	Feedback Voltage	ISW=100mA, Duty Cycle = 66%	86		110	mV
IFB	FB Pin Bias Current				150	nA
IS	Supply Current	VSHDN > 0V		2.8	3.5	mA
		VSHDN = 0V		0.05	1.0	μA
Fosc	Switching Frequency		0.68	0.8	1.0	MHz
D	Maximum Duty Cycle			85		%
Iout	Switch Current Limit			320		mA
ILEAKAGE	Switch Leakage Current	VSW= 5V		0.01	5	μA
Vcesat	Switch Vcesat	ISW = 200mA		150		mV
ISHDN	SHDN Pin Current			90		μA
VSHDNH	SHDN Voltage High		1.5			V
SHDNL	SHDN Voltage Low				0.4	V
VOVP	Over Voltage Protection	Vout Rising		21		V

SOT-23-6L PACKAGE OUTLINE

Symbol	Dimensions In Millimeters		Dimensions In Inches	
	Min	Max	Min	Max
A	1.050	1.250	0.041	0.049
A1	0.000	0.100	0.000	0.004
A2	1.050	1.150	0.041	0.045
b	0.300	0.400	0.012	0.016
c	0.100	0.200	0.004	0.008
D	2.820	3.020	0.111	0.119
E	1.500	1.700	0.059	0.067
E1	2.650	2.950	0.104	0.116
e	0.950TYP		0.037TYP	
e1	1.800	2.000	0.071	0.079
L	0.700REF		0.028REF	
L1	0.300	0.600	0.012	0.024
theta	0°	8°	0°	8°