

DATA SHEET

TDA3508

Video control combination circuit
with automatic cut-off control

Product specification
Supersedes data of April 1993
File under Integrated Circuits, IC02

1996 Oct 25

Video control combination circuit with automatic cut-off control

TDA3508

FEATURES

- Capacitive coupling of the colour difference and luminance input signals with black level clamping in the input stages
- Linear saturation control acting on the colour difference signals
- (G-Y) and RGB matrix
- Linear transmission of inserted signals
- Equal black levels for inserted and matrixed signals
- Three identical channels for the RGB signals
- Linear contrast and brightness controls, operating on both the inserted and matrixed RGB signals
- Peak beam current limiting input
- Clamping, horizontal and vertical blanking of the three input signals controlled by a 3-level sandcastle pulse
- Three DC gain controls for the RGB output signals (white point adjustment)
- Emitter-follower outputs for driving the RGB output stages
- Input for automatic cut-off control with compensation for leakage current of the picture tube.

GENERAL DESCRIPTION

The TDA3508 is an integrated circuit which performs video control functions in a PAL/SECAM decoder for negative colour difference signals $-(R-Y)$ and $-(B-Y)$.

The required input signals are luminance and colour difference and a 3-level sandcastle pulse for control purposes. Linear RGB signals can be inserted from an external source. RGB output signals are available for driving the video output stages. The circuit provides automatic cut-off control of the picture tube.

ORDERING INFORMATION

TYPE NUMBER	PACKAGE		
	NAME	DESCRIPTION	VERSION
TDA3508	DIP28	plastic dual in-line package; 28 leads (600 mil)	SOT117-1

Video control combination circuit with automatic cut-off control

TDA3508

QUICK REFERENCE DATA

All voltages referenced to pin 24 (ground).

SYMBOL	PARAMETER	MIN.	TYP.	MAX.	UNIT
V _P	supply voltage (pin 6)	–	12.0	–	V
I _P	supply current	–	95	–	mA
V _{15(p-p)}	composite video input signal (pin 15) (peak-to-peak value)	–	0.45	–	V
V _{18(p-p)}	–(B–Y) colour difference input signal (pin 18) (peak-to-peak value)	–	1.33	–	V
V _{17(p-p)}	–(R–Y) colour difference input signal (pin 17) (peak-to-peak value)	–	1.05	–	V
V _{12,13,14(b-w)}	inserted RGB signals (black-to-white value) (pins 12, 13 and 14)	–	1.0	–	V
V ₁₀	3-level sandcastle pulse (pin 10)				
	level 1	–	2.5	–	V
	level 2	–	4.5	–	V
	level 3	–	8.0	–	V
V ₂₀	control voltage for brightness (pin 20)	1.0	–	3.0	V
V ₁₉	control voltage for contrast (pin 19)	2.0	–	4.3	V
V ₁₆	control voltage for saturation (pin 16)	2.0	–	4.3	V
T _{amb}	operating ambient temperature	0	–	70	°C

Video control combination circuit with automatic cut-off control

TDA3508

BLOCK DIAGRAM

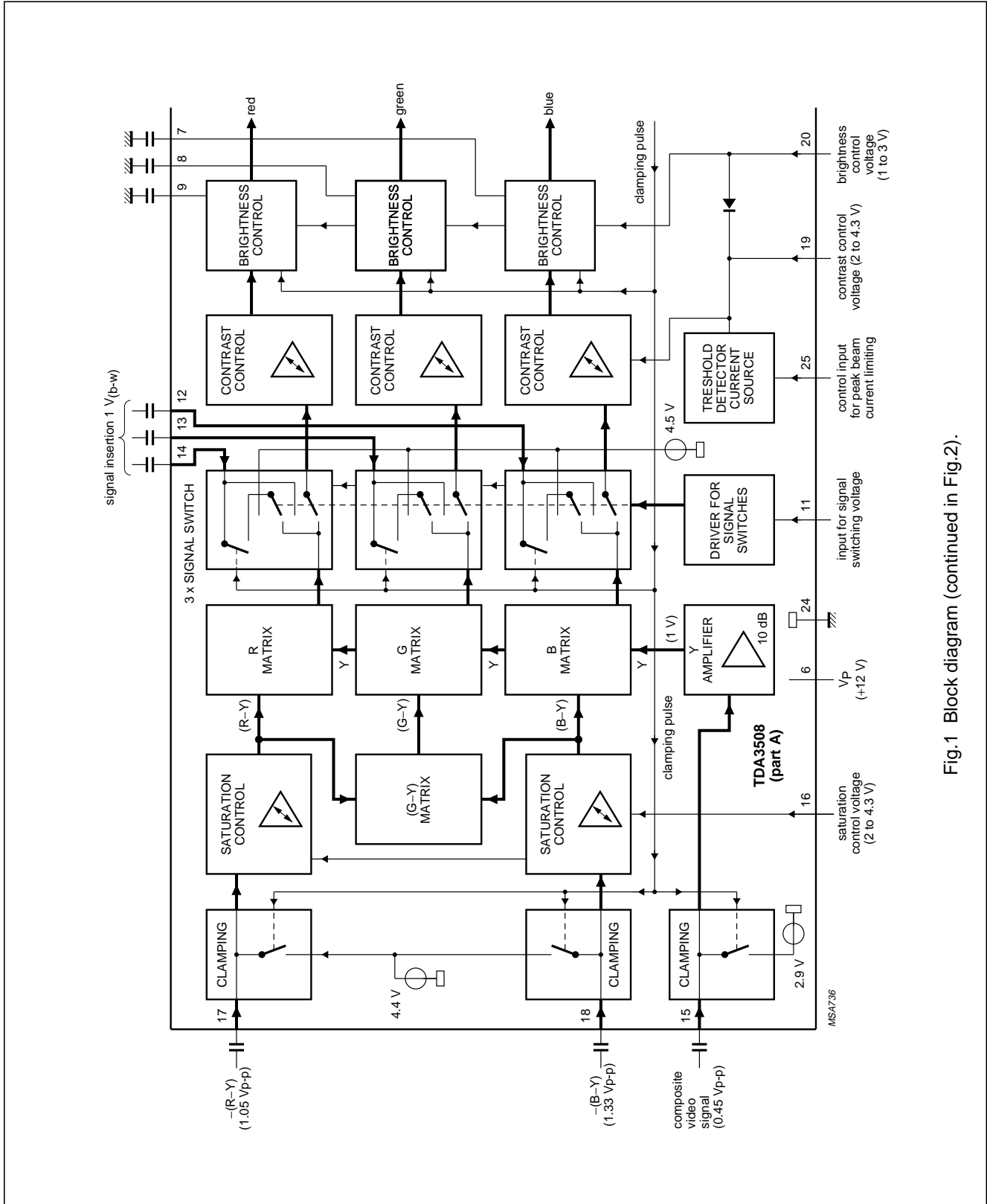

Fig.1 Block diagram (continued in Fig.2).

Video control combination circuit with automatic cut-off control

TDA3508

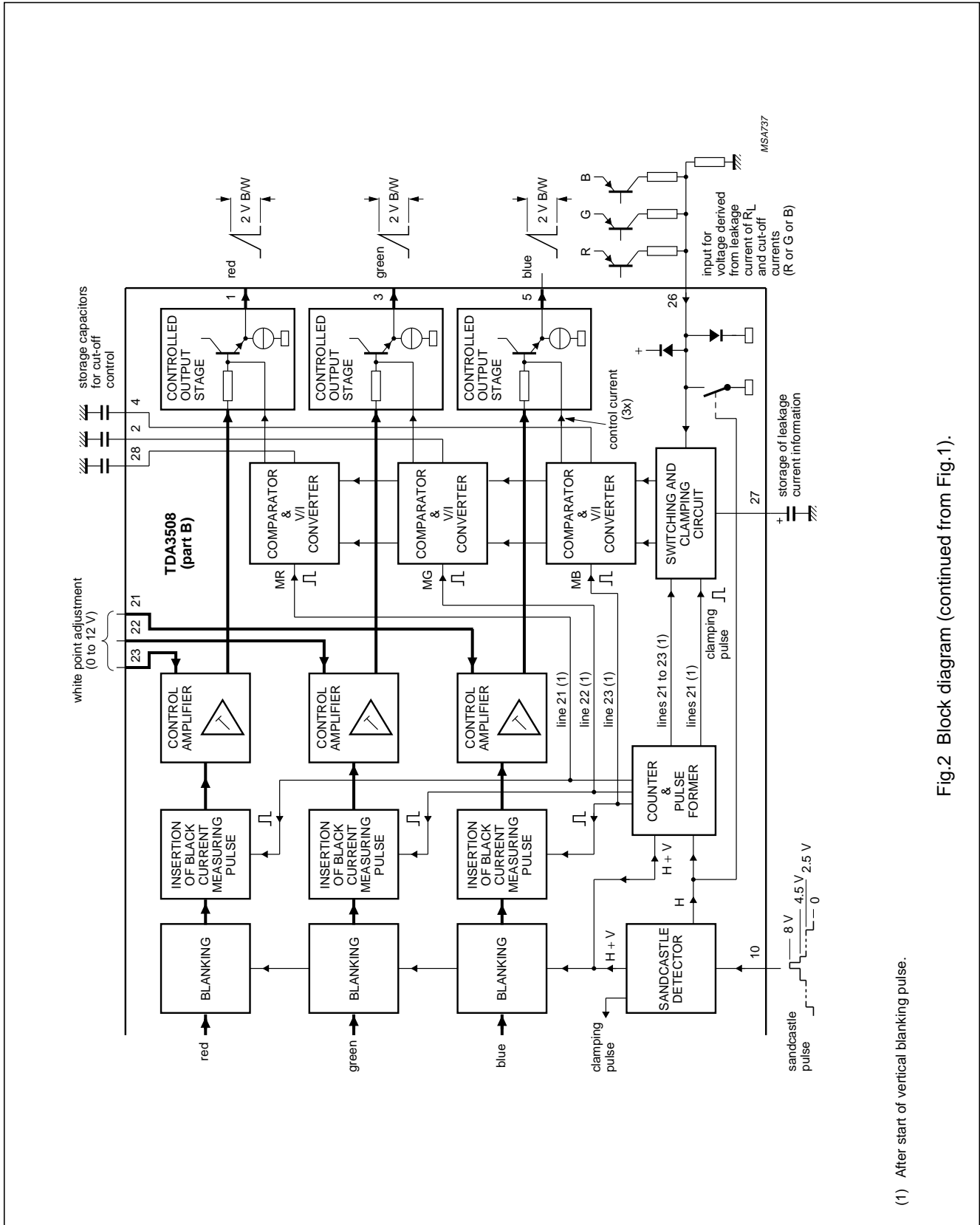

Fig.2 Block diagram (continued from Fig.1).

(1) After start of vertical blanking pulse.

Video control combination circuit with automatic cut-off control

TDA3508

PINNING

SYMBOL	PIN	DESCRIPTION
RO	1	red output
CGC	2	green storage capacitor for cut-off control
GO	3	green output
CBC	4	blue storage capacitor for cut-off control
BO	5	blue output
V _P	6	supply voltage (+12 V)
CB	7	blue storage capacitor for brightness
CG	8	green storage capacitor for brightness
CR	9	red storage capacitor for brightness
SC	10	sandcastle pulse input
FSW	11	fast switch for RGB inputs
BI	12	blue input (external signal)
GI	13	green input (external signal)
RI	14	red input (external signal)
Y	15	luminance input
SAT	16	saturation control input
-(R-Y)	17	colour difference input
-(B-Y)	18	colour difference input
CON	19	contrast control input
BRI	20	brightness control input
WPB	21	white point adjustment input; blue
WPG	22	white point adjustment input; green
WPR	23	white point adjustment input; red
GND	24	ground (0 V)
PBL	25	control input for peak beam current limiting
ACO	26	automatic cut-off control input
CSL	27	storage capacitor for leakage current
CRC	28	red storage capacitor for cut-off control

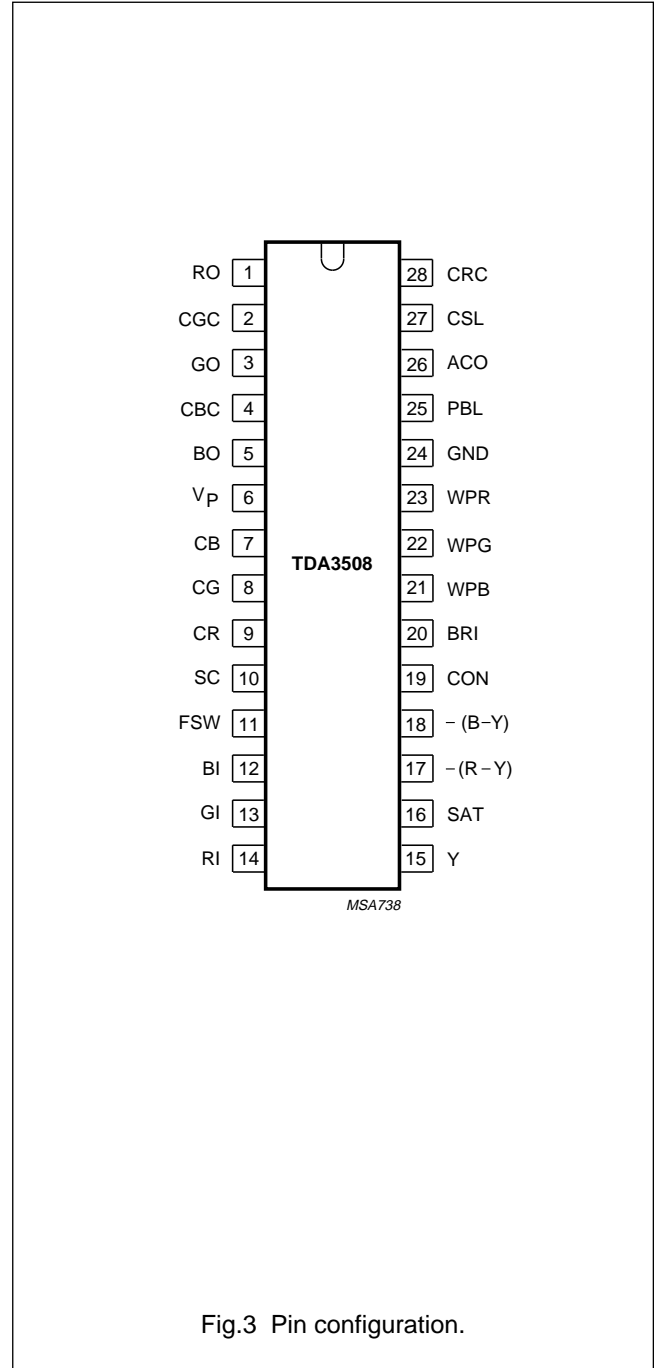

Fig.3 Pin configuration.

Video control combination circuit with automatic cut-off control

TDA3508

LIMITING VALUES

In accordance with the Absolute Maximum Rating System (IEC 134).

SYMBOL	PARAMETER	CONDITIONS	MIN.	MAX.	UNIT
V_P	supply voltage on pin 6		0	13.2	V
V_n	input voltage on pins 10, 21, 22, 23, 25 and 26		0	V_P	V
V_{11}	input voltage on pin 11		-0.5	+3.0	V
$V_{16,19,20}$	input voltage on pins 16, 19 and 20		0	$0.5V_P$	V
V_{n1}	voltage on pins 1 to 5, 7 to 9, 12 to 15, 17, 18, 27 and 28	no external DC voltage			V
$I_{1,3,5}$	output current on pins 1, 3 and 5		-	-3	mA
I_{19}	input current on pin 19		-	10	mA
I_{20}	input current on pin 20		-	5	mA
I_{25}	input current on pin 25		-5	-	mA
P_{tot}	total power dissipation		-	1.7	W
T_{amb}	operating ambient temperature		0	70	°C
T_{stg}	storage temperature		-25	+150	°C
V_{es}	electrostatic handling voltage;				
	pin 10	note 1	-500	+450	V
	all other pins	note 1	-500	+500	V

Note

- Equivalent to discharging a 200 pF capacitor via a 0 Ω series resistor.

Video control combination circuit with automatic cut-off control

TDA3508

CHARACTERISTICS

$V_P = 12\text{ V}$; $V_{12,13,14(p-p)} = 1\text{ V}$; $V_{15(p-p)} = 0.45\text{ V}$; $V_{17(p-p)} = 1.05\text{ V}$; $V_{18(p-p)} = 1.33\text{ V}$; $T_{\text{amb}} = 25\text{ °C}$; measured in application circuit of Fig.4; nominal settings of brightness, contrast, saturation and white point adjustment; all voltages referenced to ground (pin 24); unless otherwise specified.

SYMBOL	PARAMETER	CONDITIONS	MIN.	TYP.	MAX.	UNIT
Supply (pin 6)						
V_P	supply voltage		10.8	12.0	13.2	V
I_P	supply current	note 1	–	95	125	mA
Colour difference inputs (pins 17 and 18)						
$V_{17(p-p)}$	–(R–Y) input signal (pin 17) (peak-to-peak value)	for saturated colour bar with 75% of maximum amplitude	–	1.05	1.48	V
$V_{18(p-p)}$	–(B–Y) input signal (pin 18) (peak-to-peak value)	for saturated colour bar with 75% of maximum amplitude	–	1.33	1.88	V
$ I_{17,18} $	input current during scanning		–	–	1.0	μA
R_I	input resistance		1.0	–	–	$\text{M}\Omega$
$V_{17,18}$	internal DC voltage due to clamping	note 2	3.8	4.4	4.8	V
Saturation control (pin 16)						
V_{16}	input control voltages	maximum saturation; note 2	4.0	4.2	4.4	V
		nominal saturation 6 dB below maximum; note 2	2.9	3.1	3.3	V
		–26 dB saturation referenced to maximum; note 2	1.9	2.1	2.3	V
SAT_{min}	minimum saturation	$V_{16} = 1.8\text{ V}$	46	50	–	dB
I_{16}	input current		–	–	20	μA
(G–Y) matrix (see note 3)						
Luminance input (pin 15)						
$V_{15(p-p)}$	composite video input signal (peak-to-peak value)		–	450	630	mV
$ I_{15} $	input current during scanning		–	–	1.0	μA
R_{15}	input resistance		0.1	–	–	$\text{M}\Omega$
C_{15}	input capacitance		–	–	5	pF
V_{15}	input DC voltage due to clamping	note 2	2.5	2.9	3.3	V
m	linearity	nominal settings	0.85	–	–	
RGB channels						
SIGNAL SWITCHING INPUT (PIN 11)						
V_{11}	normal state voltage; no insertion		0	–	0.4	V
V_{11}	voltage level for insertion on		0.9	–	3.0	V
C_{11}	input capacitance		–	–	10	pF
I_{11}	input current	$V_{11} = 0\text{ to }3\text{ V}$	–100	–	+450	μA

Video control combination circuit with automatic cut-off control

TDA3508

SYMBOL	PARAMETER	CONDITIONS	MIN.	TYP.	MAX.	UNIT
SIGNAL INSERTION: RI, GI AND BI (PINS 14, 13 AND 12)						
$V_{14,13,12(b-w)}$	external RGB input signals (black-to-white value)		–	1.0	1.4	V
$ I_{14,13,12} $	input current during scanning		–	–	1.0	μA
$V_{14,13,12}$	internal DC voltage due to clamping	notes 2 and 4	4.0	4.5	5.0	V
Contrast control (pin 19)						
V_{19}	control voltage	maximum contrast; note 2	4.0	4.2	4.4	V
		nominal contrast 3 dB below maximum; note 2	3.4	3.6	3.8	V
		–10 dB below maximum; note 2	2.6	2.8	3.0	V
CON	minimum contrast	referenced to maximum; $V_{19} = 2\text{ V}$	18	21	29	dB
I_{19}	input current	$V_{25} > 6\text{ V}$	–	–	2.0	μA
RGB_{diff}	difference between RGB channels	contrast –10 dB below maximum	–	–	0.6	dB
Peak beam current limiting (pin 25)						
V_{25}	internal DC bias voltage	note 2	5.3	5.5	5.7	V
R_{25}	input resistance		–	10	–	$\text{k}\Omega$
I_{19}	input current at contrast control input	$V_{25} = 4.5\text{ V}$	10	20	34	mA
Brightness control (pin 20)						
V_{20}	control voltage	note 2	1.0	–	3.0	V
I_{20}	input current	no beam current limiting	–	–	–10	μA
$\Delta V_{\text{blk}(b-w)}$	shift of black level in the control range referenced to the luminance signal (black-to-white value)	$\Delta V_{20} = 1\text{ V}$	–	± 50	–	%
	tracking		95	–	–	%
Internal signal limiting (RGB)						
	signal limiting referenced to nominal luminance and nominal black level	black	–	–25	–	%
		white	115	120	125	%
White point adjustment (pins 21, 22 and 23); note 2						
G_v	AC voltage gain	$V_{21,22,23} = 5.5\text{ V}$; note 5	–	100	–	%
		$V_{21,22,23} = 0\text{ V}$; note 5	–35	–40	–	%
		$V_{21,22,23} = 12\text{ V}$; note 5	+35	+40	–	%
R_I	input resistance		–	20	–	$\text{k}\Omega$

Video control combination circuit with automatic cut-off control

TDA3508

SYMBOL	PARAMETER	CONDITIONS	MIN.	TYP.	MAX.	UNIT
RGB outputs (emitter follower; pins 1, 3 and 5)						
$V_{1,3,5}$	output voltage	black-to-white positive	1.5	2.0	2.5	V
$V_{1,3,5}$	black level without automatic cut-off control	$V_{28,2,4} = 10$ V; note 2	6.1	6.9	7.7	V
$\Delta V_{1,3,5}$	difference in black level between RGB channels due to variation of contrast control		–	–	10	mV
$V_{1,3,5}$	cut-off control range	note 2	4.0	4.6	–	V
$ I_{1,3,5} $	internal current source		2.0	3.0	–	mA
Automatic cut-off control (pin 26); notes 2, 6, 7, 8 and 9						
V_{26}	input voltage		0	–	6.5	V
V_{26}	voltage difference between cut-off current measurement and leakage current measurement		0.5	0.64	0.72	V
Gain data (at nominal brightness, contrast, saturation and white point settings)						
$G_{v1,3,5-15}$	voltage gain with respect to luminance input (pin 15)		14	16	18	dB
$\alpha_{1,3,5-15}$	frequency response of luminance path	$f_i = 0$ to 5 MHz	–	–	3	dB
G_v	voltage gain with respect to colour difference inputs (pins 1 to 17 and 5 to 18)		3	6	9	dB
α	frequency response of colour difference paths (pins 1 to 17 and 5 to 18)	$f_i = 0$ to 2 MHz	–	–	3	dB
G_v	voltage gain with respect to inserted signals (pins 1 to 14, 3 to 13 and 5 to 12)		4	6	8	dB
α	frequency response of inserted signal paths (pins 1 to 14, 3 to 13 and 5 to 12)	$f_i = 0$ to 10 MHz	–	–	3	dB
t_r	rise time of RGB output signals (pins 1, 3 and 5)		–	40	–	ns
t_f	fall time of RGB output signals (pins 1, 3 and 5)		–	40	–	ns
$\Delta t_{1,3,5}$	difference in transition times between R, G and B channels		–	0	15	ns
t_d	delay time between signal switching and signal insertion		–25	–	+25	ns
$\Delta G_{v1,3,5}$	difference in gain between normal and signal insertion mode		–	–	10	%

Video control combination circuit with automatic cut-off control

TDA3508

SYMBOL	PARAMETER	CONDITIONS	MIN.	TYP.	MAX.	UNIT
Sandcastle pulse detector (pin 10)						
V ₁₀	the following amplitudes are required for separating the various pulses	horizontal and vertical blanking; notes 10 and 11	1.0	1.5	2.0	V
		required pulses (H + V); note 10	2.1	2.5	2.9	V
		horizontal; note 10	3.0	3.5	4.0	V
		required pulses (H); note 10	4.1	4.5	5.0	V
		clamping; notes 10 and 12	6.5	7.0	7.5	V
		required pulses; note 10	7.6	–	12.0	V
		no keying; note 10	–	–	1.0	V
I ₁₀	input current		–	–	–110	μA

Notes

- Maximum value <110 mA after warm-up.
- Values are proportional to the supply voltage.
- Matrixed according to equation $V_{(G-Y)} = -0.51V_{(R-Y)} - 0.19V_{(B-Y)}$.
- When $V_{11-24} < 0.4$ V during clamping time, the black levels of the inserted RGB signals are clamped on the black levels of the internal RGB signals. When $V_{11-24} > 0.9$ V during clamping time, the black levels of the inserted RGB signals are clamped on an internal DC voltage (correct clamping of the external RGB signals is possible only when they are synchronous with the sandcastle pulse).
- When pins 21, 22 and 23 are not connected, an internal bias voltage of 5.5 V is supplied.
- Automatic cut-off control measurement occurs in the following lines after start of the vertical blanking pulse:
 - line 20: measurement of leakage current (R + G + B).
 - line 21: measurement of red cut-off current.
 - line 22: measurement of green cut-off current.
 - line 23: measurement of blue cut-off current.
- Black level of the measured channel is nominal; the other two channels are blanked to ultra-black.
- All three channels blanked to ultra-black. The cut-off control cycle occurs when the vertical blanking part of the sandcastle pulse contains more than 3 line pulses. The internal blanking continues until the end of the last measured line. The vertical blanking pulse is not allowed to contain more than 34 line pulses, otherwise another control cycle begins.
- Input pin 26 switches to ground during horizontal flyback.
- The sandcastle pulse is compared with three internal thresholds (proportional to V_P) and the given levels separate the various pulses.
- Blanked to ultra-black (–25%).
- Pulse duration ≥ 3.5 μs.

Video control combination circuit with automatic cut-off control

TDA3508

APPLICATION INFORMATION

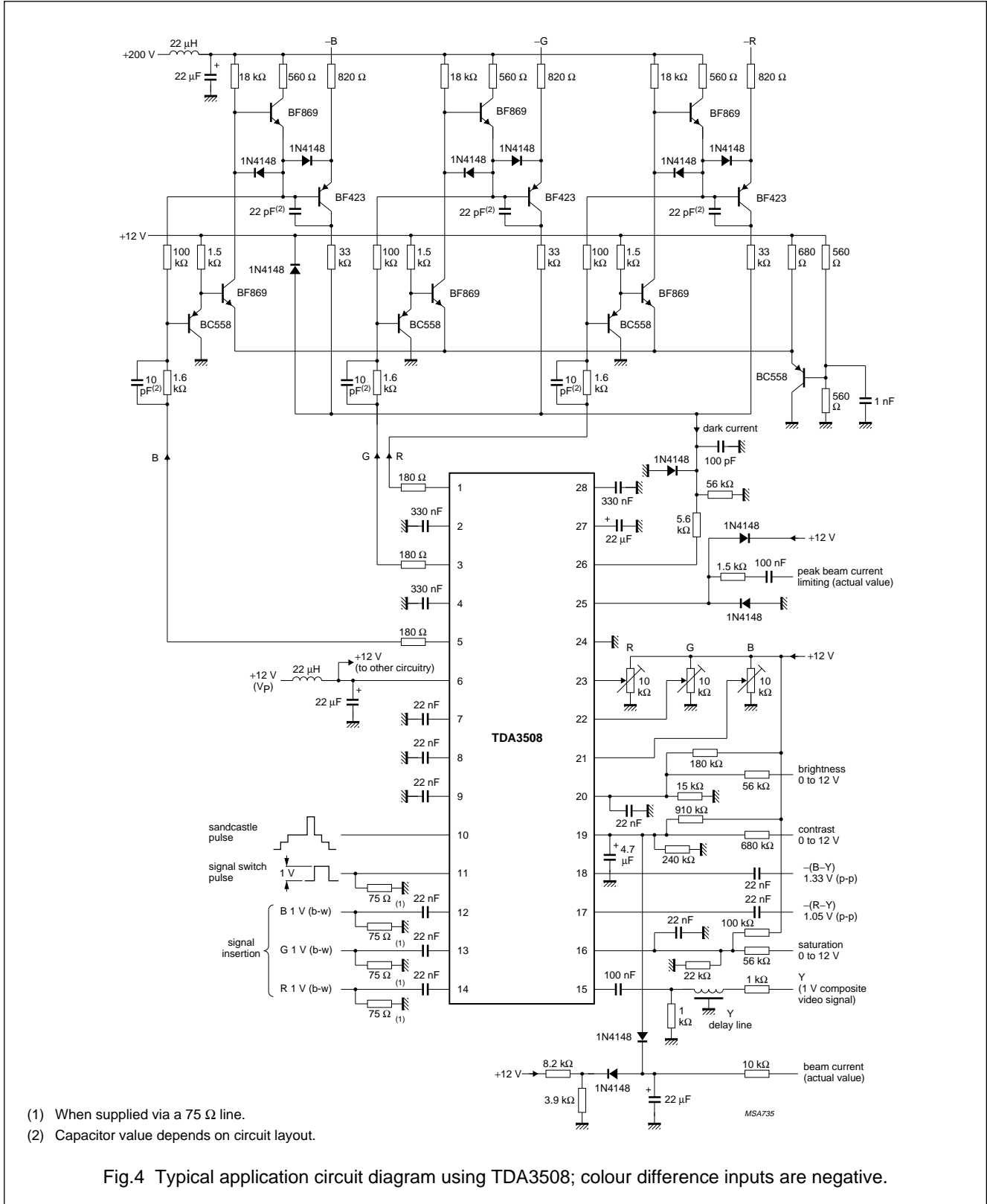

Video control combination circuit with automatic cut-off control

TDA3508

PACKAGE OUTLINE

DIP28: plastic dual in-line package; 28 leads (600 mil)

SOT117-1

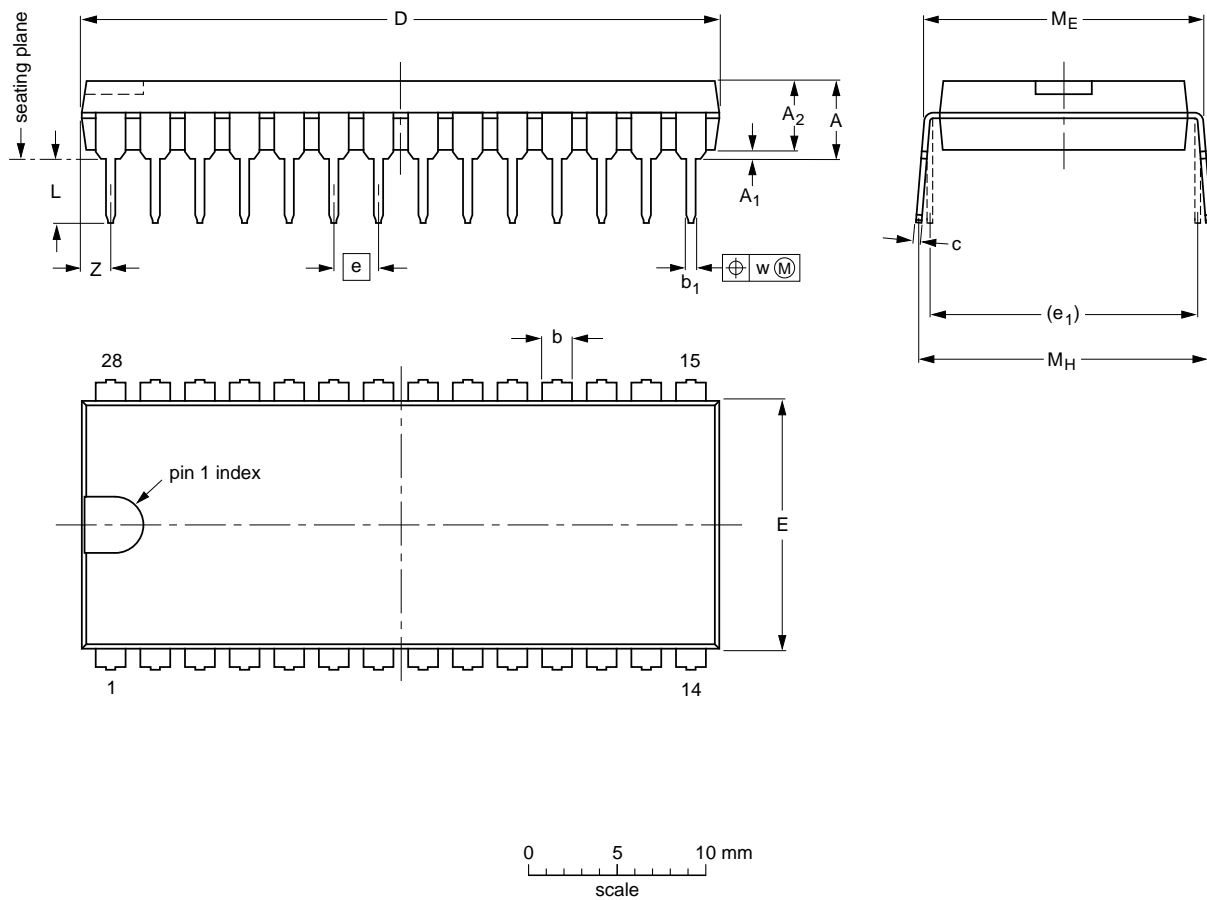

DIMENSIONS (inch dimensions are derived from the original mm dimensions)

UNIT	A max.	A ₁ min.	A ₂ max.	b	b ₁	c	D ⁽¹⁾	E ⁽¹⁾	e	e ₁	L	M _E	M _H	w	Z ⁽¹⁾ max.
mm	5.1	0.51	4.0	1.7 1.3	0.53 0.38	0.32 0.23	36.0 35.0	14.1 13.7	2.54	15.24	3.9 3.4	15.80 15.24	17.15 15.90	0.25	1.7
inches	0.20	0.020	0.16	0.066 0.051	0.020 0.014	0.013 0.009	1.41 1.34	0.56 0.54	0.10	0.60	0.15 0.13	0.62 0.60	0.68 0.63	0.01	0.067

Note

1. Plastic or metal protrusions of 0.25 mm maximum per side are not included.

OUTLINE VERSION	REFERENCES				EUROPEAN PROJECTION	ISSUE DATE
	IEC	JEDEC	EIAJ			
SOT117-1	051G05	MO-015AH				92-11-17 95-01-14

Video control combination circuit with automatic cut-off control

TDA3508

SOLDERING

Introduction

There is no soldering method that is ideal for all IC packages. Wave soldering is often preferred when through-hole and surface mounted components are mixed on one printed-circuit board. However, wave soldering is not always suitable for surface mounted ICs, or for printed-circuits with high population densities. In these situations reflow soldering is often used.

This text gives a very brief insight to a complex technology. A more in-depth account of soldering ICs can be found in our "IC Package Databook" (order code 9398 652 90011).

Soldering by dipping or by wave

The maximum permissible temperature of the solder is 260 °C; solder at this temperature must not be in contact with the joint for more than 5 seconds. The total contact time of successive solder waves must not exceed 5 seconds.

The device may be mounted up to the seating plane, but the temperature of the plastic body must not exceed the specified maximum storage temperature ($T_{stg\ max}$). If the printed-circuit board has been pre-heated, forced cooling may be necessary immediately after soldering to keep the temperature within the permissible limit.

Repairing soldered joints

Apply a low voltage soldering iron (less than 24 V) to the lead(s) of the package, below the seating plane or not more than 2 mm above it. If the temperature of the soldering iron bit is less than 300 °C it may remain in contact for up to 10 seconds. If the bit temperature is between 300 and 400 °C, contact may be up to 5 seconds.

DEFINITIONS

Data sheet status	
Objective specification	This data sheet contains target or goal specifications for product development.
Preliminary specification	This data sheet contains preliminary data; supplementary data may be published later.
Product specification	This data sheet contains final product specifications.
Limiting values	
Limiting values given are in accordance with the Absolute Maximum Rating System (IEC 134). Stress above one or more of the limiting values may cause permanent damage to the device. These are stress ratings only and operation of the device at these or at any other conditions above those given in the Characteristics sections of the specification is not implied. Exposure to limiting values for extended periods may affect device reliability.	
Application information	
Where application information is given, it is advisory and does not form part of the specification.	

LIFE SUPPORT APPLICATIONS

These products are not designed for use in life support appliances, devices, or systems where malfunction of these products can reasonably be expected to result in personal injury. Philips customers using or selling these products for use in such applications do so at their own risk and agree to fully indemnify Philips for any damages resulting from such improper use or sale.

Philips Semiconductors – a worldwide company

Argentina: see South America

Australia: 34 Waterloo Road, NORTH RYDE, NSW 2113,
Tel. +61 2 9805 4455, Fax. +61 2 9805 4466

Austria: Computerstr. 6, A-1101 WIEN, P.O. Box 213,
Tel. +43 1 60 101, Fax. +43 1 60 101 1210

Belarus: Hotel Minsk Business Center, Bld. 3, r. 1211, Volodarski Str. 6,
220050 MINSK, Tel. +375 172 200 733, Fax. +375 172 200 773

Belgium: see The Netherlands

Brazil: see South America

Bulgaria: Philips Bulgaria Ltd., Energoproject, 15th floor,
51 James Bourchier Blvd., 1407 SOFIA,
Tel. +359 2 689 211, Fax. +359 2 689 102

Canada: PHILIPS SEMICONDUCTORS/COMPONENTS,
Tel. +1 800 234 7381

China/Hong Kong: 501 Hong Kong Industrial Technology Centre,
72 Tat Chee Avenue, Kowloon Tong, HONG KONG,
Tel. +852 2319 7888, Fax. +852 2319 7700

Colombia: see South America

Czech Republic: see Austria

Denmark: Prags Boulevard 80, PB 1919, DK-2300 COPENHAGEN S,
Tel. +45 32 88 2636, Fax. +45 31 57 1949

Finland: Sinikalliontie 3, FIN-02630 ESPOO,
Tel. +358 9 615800, Fax. +358 9 61580/xxx

France: 4 Rue du Port-aux-Vins, BP317, 92156 SURESNES Cedex,
Tel. +33 1 40 99 6161, Fax. +33 1 40 99 6427

Germany: Hammerbrookstraße 69, D-20097 HAMBURG,
Tel. +49 40 23 53 60, Fax. +49 40 23 536 300

Greece: No. 15, 25th March Street, GR 17778 TAVROS/ATHENS,
Tel. +30 1 4894 339/239, Fax. +30 1 4814 240

Hungary: see Austria

India: Philips INDIA Ltd, Shivsagar Estate, A Block, Dr. Annie Besant Rd.
Worli, MUMBAI 400 018, Tel. +91 22 4938 541, Fax. +91 22 4938 722

Indonesia: see Singapore

Ireland: Newstead, Clonskeagh, DUBLIN 14,
Tel. +353 1 7640 000, Fax. +353 1 7640 200

Israel: RAPAC Electronics, 7 Kehilat Saloniki St, TEL AVIV 61180,
Tel. +972 3 645 0444, Fax. +972 3 649 1007

Italy: PHILIPS SEMICONDUCTORS, Piazza IV Novembre 3,
20124 MILANO, Tel. +39 2 6752 2531, Fax. +39 2 6752 2557

Japan: Philips Bldg 13-37, Kohnan 2-chome, Minato-ku, TOKYO 108,
Tel. +81 3 3740 5130, Fax. +81 3 3740 5077

Korea: Philips House, 260-199 Itaewon-dong, Yongsan-ku, SEOUL,
Tel. +82 2 709 1412, Fax. +82 2 709 1415

Malaysia: No. 76 Jalan Universiti, 46200 PETALING JAYA, SELANGOR,
Tel. +60 3 750 5214, Fax. +60 3 757 4880

Mexico: 5900 Gateway East, Suite 200, EL PASO, TEXAS 79905,
Tel. +9-5 800 234 7381

Middle East: see Italy

Netherlands: Postbus 90050, 5600 PB EINDHOVEN, Bldg. VB,
Tel. +31 40 27 82785, Fax. +31 40 27 88399

New Zealand: 2 Wagener Place, C.P.O. Box 1041, AUCKLAND,
Tel. +64 9 849 4160, Fax. +64 9 849 7811

Norway: Box 1, Manglerud 0612, OSLO,
Tel. +47 22 74 8000, Fax. +47 22 74 8341

Philippines: Philips Semiconductors Philippines Inc.,
106 Valero St. Salcedo Village, P.O. Box 2108 MCC, MAKATI,
Metro MANILA, Tel. +63 2 816 6380, Fax. +63 2 817 3474

Poland: Ul. Lukiska 10, PL 04-123 WARSZAWA,
Tel. +48 22 612 2831, Fax. +48 22 612 2327

Portugal: see Spain

Romania: see Italy

Russia: Philips Russia, Ul. Usatcheva 35A, 119048 MOSCOW,
Tel. +7 095 247 9145, Fax. +7 095 247 9144

Singapore: Lorong 1, Toa Payoh, SINGAPORE 1231,
Tel. +65 350 2538, Fax. +65 251 6500

Slovakia: see Austria

Slovenia: see Italy

South Africa: S.A. PHILIPS Pty Ltd., 195-215 Main Road Martindale,
2092 JOHANNESBURG, P.O. Box 7430 Johannesburg 2000,
Tel. +27 11 470 5911, Fax. +27 11 470 5494

South America: Rua do Rocio 220, 5th floor, Suite 51,
04552-903 São Paulo, SÃO PAULO - SP, Brazil,
Tel. +55 11 821 2333, Fax. +55 11 829 1849

Spain: Balmes 22, 08007 BARCELONA,
Tel. +34 3 301 6312, Fax. +34 3 301 4107

Sweden: Kottbygatan 7, Akalla, S-16485 STOCKHOLM,
Tel. +46 8 632 2000, Fax. +46 8 632 2745

Switzerland: Allmendstrasse 140, CH-8027 ZÜRICH,
Tel. +41 1 488 2686, Fax. +41 1 481 7730

Taiwan: PHILIPS TAIWAN Ltd., 23-30F, 66,
Chung Hsiao West Road, Sec. 1, P.O. Box 22978,
TAIPEI 100, Tel. +886 2 382 4443, Fax. +886 2 382 4444

Thailand: PHILIPS ELECTRONICS (THAILAND) Ltd.,
209/2 Sanpavuth-Bangna Road Prakanong, BANGKOK 10260,
Tel. +66 2 745 4090, Fax. +66 2 398 0793

Turkey: Talatpasa Cad. No. 5, 80640 GÜLTEPE/ISTANBUL,
Tel. +90 212 279 2770, Fax. +90 212 282 6707

Ukraine: PHILIPS UKRAINE, 4 Patrice Lumumba str., Building B, Floor 7,
252042 KIEV, Tel. +380 44 264 2776, Fax. +380 44 268 0461

United Kingdom: Philips Semiconductors Ltd., 276 Bath Road, Hayes,
MIDDLESEX UB3 5BX, Tel. +44 181 730 5000, Fax. +44 181 754 8421

United States: 811 East Arques Avenue, SUNNYVALE, CA 94088-3409,
Tel. +1 800 234 7381

Uruguay: see South America

Vietnam: see Singapore

Yugoslavia: PHILIPS, Trg N. Pasica 5/v, 11000 BEOGRAD,
Tel. +381 11 625 344, Fax. +381 11 635 777

For all other countries apply to: Philips Semiconductors, Marketing & Sales Communications,
Building BE-p, P.O. Box 218, 5600 MD EINDHOVEN, The Netherlands, Fax. +31 40 27 24825

Internet: <http://www.semiconductors.philips.com>

© Philips Electronics N.V. 1996

SCA52

All rights are reserved. Reproduction in whole or in part is prohibited without the prior written consent of the copyright owner.

The information presented in this document does not form part of any quotation or contract, is believed to be accurate and reliable and may be changed without notice. No liability will be accepted by the publisher for any consequence of its use. Publication thereof does not convey nor imply any license under patent- or other industrial or intellectual property rights.

Printed in The Netherlands

537021/1200/02/pp16

Date of release: 1996 Oct 25

Document order number: 9397 750 00968

Let's make things better.

**Philips
Semiconductors**



PHILIPS