

DATA SHEET

TDA3602

Multiple output voltage regulator

Product specification
File under Integrated Circuits, IC01

July 1994

Multiple output voltage regulator

TDA3602

FEATURES

- Two V_P state controlled regulators (REG1 and REG2)
- Regulator 3 operates during load dump or thermal shutdown
- Multi-function control pin
- A back-up circuit for Regulator 3 via a single capacitor
- Supply voltage of -6 V to 50 V (a voltage of -3 V on V_P does not discharge capacitor C_{bu})
- Low reverse current Regulator 3
- Low quiescent current in coma mode
- HOLD output
- RESET output (LOW at load dump)
- High ripple rejection.

PROTECTIONS

- Foldback current limit protection (Regulators 1 and 2)
- Load dump protection
- Thermal protection
- DC short-circuit safe to ground and V_P of all regulator outputs
- Reverse polarity safe of pin 1 (V_P). No high currents are flowing which can damage the IC
- Capable of handling high energy on the regulator outputs.

GENERAL DESCRIPTION

The TDA3602 is a multiple output voltage regulator, intended for use in car radios with or without a microprocessor. It contains two fixed voltage regulators with foldback current protection (Regulators 1 and 2), and one fixed voltage regulator that also operates during load dump and thermal shutdown. This regulator can be used to supply a microprocessor.

A back-up circuit supplies Regulator 3 during a short period after the power is cut off (negative field decay or engine start procedure). A state control pin (pin 4) controls the device, which can be switched through four stages using the information at this pin. The switching levels at this pin contain hysteresis.

RESET and HOLD outputs can be used to interface with a microprocessor. The RESET signal can be used to call up or initialize a microprocessor (power-on reset). The HOLD signal can be used to control the power stages (mute signal in a low end application), or to generate a HOLD interrupt (microprocessor application).

An internal Zener diode on the back-up pin allows this pin to withstand a load dump when supplied by the pin using a $100\ \Omega$ series resistor.

The supply pin can withstand load dump pulses and negative supply voltages.

Multiple output voltage regulator

TDA3602

QUICK REFERENCE DATA

SYMBOL	PARAMETER	CONDITIONS	MIN.	TYP.	MAX.	UNIT
Supply						
V _P	positive supply voltage operating		9.2	14.4	18	V
	Regulator 3 on		6.0	14.4	18	V
	jump start		–	–	30	V
	load dump; Regulator 3 on operating	note 1	–	–	50	V
	load dump; Regulator 3 on	note 1	6.5	–	30	V
I _P	total quiescent current	coma mode	–	290	–	μA
T _{vj}	virtual junction temperature		–	–	150	°C
Voltage regulators						
V _{R1}	output voltage Regulator 1	0.5 mA ≤ I _{R1} ≤ 250 mA	8.2	8.5	8.8	V
V _{R2}	output voltage Regulator 2	0.5 mA ≤ I _{R2} ≤ 140 mA	4.8	5.0	5.2	V
V _{R3}	output voltage Regulator 3	0.5 mA ≤ I _{R3} ≤ 50 mA	4.8	5	5.2	V

Note

- V_{bu} (pin 8) supplied by V_{P2} with a 100 Ω series resistor and I_{REG3} < 10 mA.

ORDERING INFORMATION

EXTENDED TYPE NUMBER	PACKAGE			
	PINS	PIN POSITION	MATERIAL	CODE
TDA3602 ⁽¹⁾	9	SIL	plastic	SOT110

Note

- SOT110-1; 1996 August 21.

Multiple output voltage regulator

TDA3602

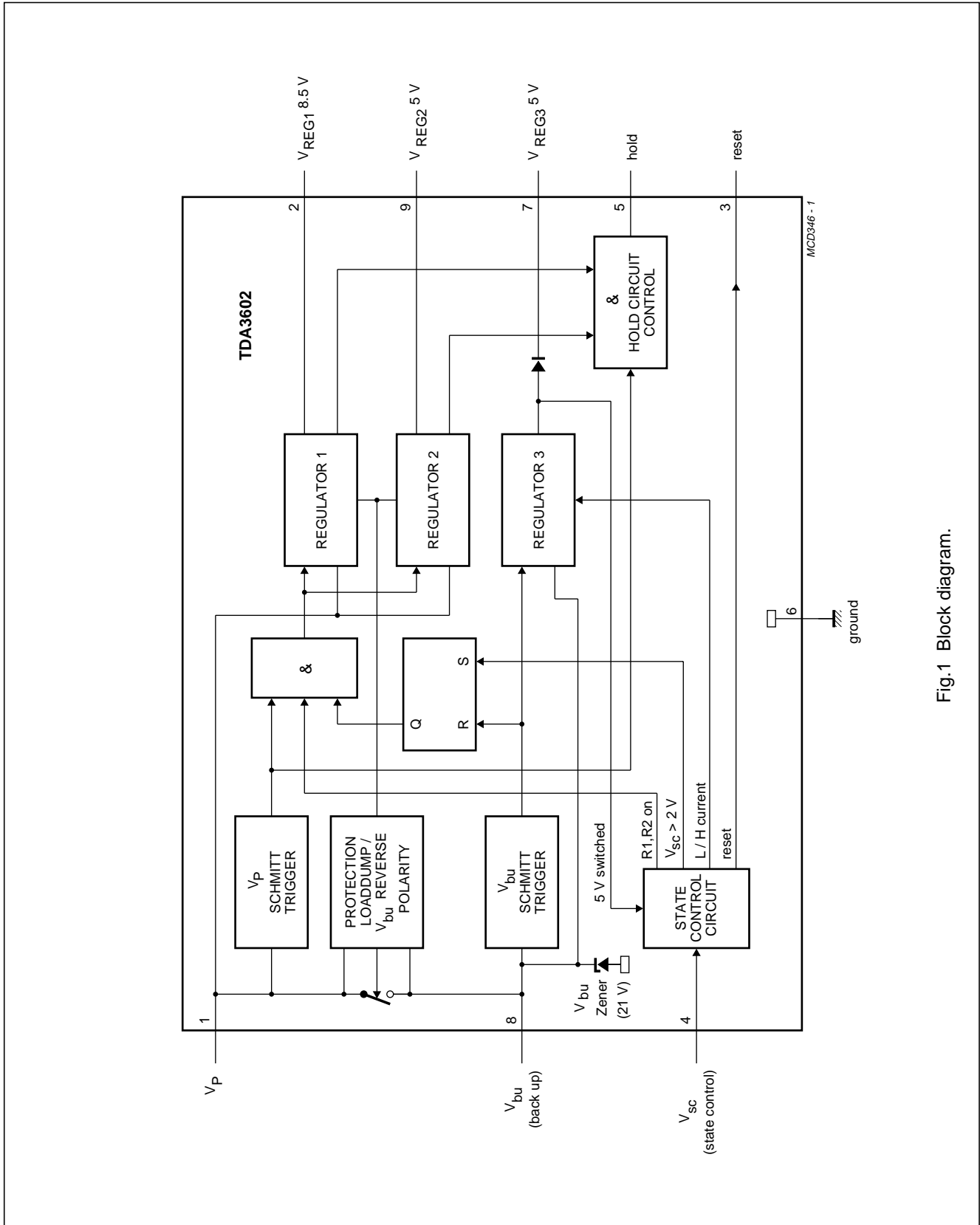

Fig.1 Block diagram.

Multiple output voltage regulator

TDA3602

PINNING

SYMBOL	PIN	DESCRIPTION
V _P	1	positive supply voltage
REG1	2	Regulator 1 output
RESET	3	reset output
V _{sc}	4	state control input
HOLD	5	hold output
GND	6	ground
REG3	7	Regulator 3 output
V _{bu}	8	back-up
REG2	9	Regulator 2 output

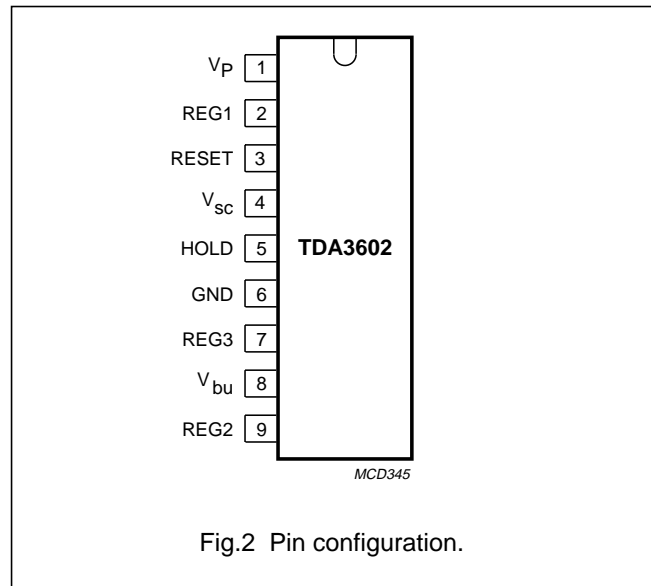

Fig.2 Pin configuration.

FUNCTIONAL DESCRIPTION

This multiple output voltage regulator contains three fixed voltage regulators, numbered 1, 2 and 3. Two of these can be switched between the on and off states using the state control pin (pin 4). The third (Regulator 3), which is continuously in, can be switched by the state control pin between a low and a high current mode.

In addition to Regulators 1 and 2, the device is supplied by an internal switch that is open when the supply voltage falls below the back-up voltage (negative field decay or engine start procedure), or during a load dump. (During this load dump, Regulators 1 and 2 are switched off and RESET is switched LOW). This switched supply voltage (the so-called back-up voltage (V_{bu}), is available at pin 8. An electrolytic capacitor can be connected to this pin, and the charge on this capacitor can be used to supply the device for a short period after the supply voltage is removed.

Three pins are provided for interfacing with a microprocessor:

- state control pin
- hold output pin
- reset output pin.

When the supply voltage (V_P) is connected to the device, V_{bu} will rise. When V_{bu} reaches 7.9 V, the device is in the power-on mode. The RESET output goes HIGH and Regulator 3 is switched on. In a microprocessor application, the RESET output can be used to call up the CPU and to initialize the program.

What follows depends on the voltage at the state control pin (V_{sc}). In most applications, when the supply voltage is connected, V_{sc} will rise slowly (e.g. by charging a capacitor). The device will leave the power-on mode and enter the reset mode when V_{sc} rises above 2.2 V. In both the power-on and reset modes, Regulator 3 will be in the high current mode, Regulators 1 and 2 will be switched off and the RESET output will be HIGH.

The device will enter the wake mode when V_{sc} reaches 2.8 V. The RESET pin will go LOW and the CPU must be switched to the sleep mode. Regulator 3 is still in the high current mode.

As V_{sc} continues rising and the voltage reaches 3.6 V, the stabilizer will be switched into the sleep mode. It will be in a coma mode when V_{sc} is greater than 3.8 V. In this mode, only the relevant circuits remain operating; this is to keep the power consumption as low as possible i.e. typically 290 µA.

If the device is switched on with V_{sc} already higher than 3.8 V, the device will be switched directly from the power-on mode into the coma mode.

When V_{sc} is lowered gradually from 3.6 V (or higher) to 2 V, the device will go from sleep to reset again.

V_{sc} must be lower than 1.1 V to bring the device into the on mode; note that this is not the same as the power-on mode. In this condition, Regulator 3 is in the high current mode, both Regulators 1 and 2 are switched on and the HOLD output will be HIGH (depending on the state of V_P and the in-regulation condition of Regulators 1 and 2).

Multiple output voltage regulator

TDA3602

When the device is in the on mode, it will switch back to the reset mode when V_{SC} rises to 2 V, or when the supply voltage drops below 7.3 V.

When V_{REG3} drops below 3 V, the device will return to the power off mode, regardless of the condition the device was in.

LIMITING VALUES

In accordance with the Absolute Maximum Rating System (IEC 134).

SYMBOL	PARAMETER	CONDITIONS	MIN.	MAX.	UNIT
V_P	supply voltage				
	operating		–	18	V
	jump start	$t \leq 10$ min	–	30	V
	load dump	$t \leq 50$ ms; $t_r \geq 2.5$ ms	–	50	V
	Regulator 3 on	$V_P > -3$ V; note 1	–	30	V
	load dump	$t \leq 50$ ms; $t_r \geq 2.5$ ms; note 1	–	50	V
	reverse battery voltage		–6	–	V
T_{stg}	storage temperature	non-operating	–55	+150	°C
T_{vj}	virtual junction temperature	operating	–40	+150	°C
V_{pr}	reverse polarity	non-operating	–	6	V
P_{tot}	total power dissipation		–	15	W

Note

- V_{bu} (pin 8) supplied by V_{P2} with a 100 Ω series resistor and $I_{REG3} < 10$ mA.

THERMAL RESISTANCE

SYMBOL	PARAMETER	THERMAL RESISTANCE
$R_{th\ j-a}$	from junction to ambient in free air	50 K/W
$R_{th\ j-c}$	from junction to case (see Fig.6)	12 K/W

CHARACTERISTICS

$V_P = 14.4$ V; $T_{amb} = 25$ °C; measured in Fig.6; unless otherwise specified.

SYMBOL	PARAMETER	CONDITIONS	MIN.	TYP.	MAX.	UNIT
Supply						
V_P	supply voltage					
	operating		9.2	14.4	18	V
	Regulator 3 on	note 1	6.0	14.4	18	V
	jump start	$t \leq 10$ min	–	–	30	V
	load dump	$t \leq 50$ ms; $t_r \geq 2.5$ ms	–	–	50	V
I_P	quiescent current	$V_{SC} > 4$ V; note 2				
	$V_P = 12.4$ V		–	280	360	μ A
	$V_P = 14.4$ V		–	290	–	μ A

Multiple output voltage regulator

TDA3602

SYMBOL	PARAMETER	CONDITIONS	MIN.	TYP.	MAX.	UNIT
Schmitt triggers						
V _{P2} SCHMITT TRIGGER (FOR HOLD AND REGULATORS 1 AND 2)						
V _{thr}	rising voltage threshold		7.3	7.6	8.0	V
V _{thf}	falling voltage threshold		6.8	7.1	7.5	V
V _{hy}	hysteresis		–	0.5	–	V
REGULATOR 1 SCHMITT TRIGGER (FOR HOLD)						
V _{thr}	rising voltage threshold		–	V _{R1} – 0.2	–	V
V _{thf}	falling voltage threshold		–	V _{R1} – 0.3	–	V
V _{hy}	hysteresis		–	0.1	–	V
REGULATOR 2 SCHMITT TRIGGER (FOR HOLD)						
V _{thr}	rising voltage threshold		–	V _{R2} – 0.2	–	V
V _{thf}	falling voltage threshold		–	V _{R2} – 0.3	–	V
V _{hy}	hysteresis		–	0.1	–	V
V _{BU} SCHMITT TRIGGER (REGULATOR 3)						
V _{thr}	rising voltage threshold V _{bu}		7.3	7.9	8.4	V
V _{thf}	falling voltage threshold V _{REG3}		2.5	3	3.5	V
V _{hy}	hysteresis		–	4.9	–	V
State control pin						
V _{th}	voltage threshold between sleep and coma	note 2	–	V _{thr1} + 0.2	–	V
V _{thr1}	voltage threshold wake to sleep		3.35	3.6	3.85	V
V _{thf1}	voltage threshold sleep to wake		2.5	2.7	2.9	V
V _{hy1}	hysteresis wake/sleep		0.85	0.92	1.0	V
V _{thr2}	voltage threshold reset to wake		2.6	2.8	3.0	V
V _{thf2}	voltage threshold wake to reset		1.75	1.9	2.05	V
V _{hy2}	hysteresis reset/wake		0.85	0.92	1.0	V
V _{thr3}	voltage threshold on to reset		1.85	2.0	2.15	V
V _{thf3}	voltage threshold reset to on		1.0	1.1	1.2	V
V _{hy3}	hysteresis on/reset		0.85	0.92	1.0	V
I _{scl}	input current	V _{sc} ≤ 0.8 V V _{sc} ≥ 4 V	– –	– –	–1 1	μA μA

Multiple output voltage regulator

TDA3602

SYMBOL	PARAMETER	CONDITIONS	MIN.	TYP.	MAX.	UNIT
Reset output						
V _{OL}	LOW level output voltage	I _{OL} = 0	0	0.2	0.8	V
V _{OH}	HIGH level output voltage		2.0	5.0	5.25	V
I _{OL}	LOW level output current	V _{OL} ≤ 0.8 V	0.3	0.8	–	mA
I _{OH}	HIGH level output current	V _{OH} > 3 V	–0.3	–2.0	–	mA
Hold output						
V _{OL}	LOW level output voltage	I _{OL} = 0	0	0.2	0.8	V
V _{OH}	HIGH level output voltage		2.0	5.0	5.25	V
I _{OL}	LOW level output current	V _{OL} ≤ 0.8 V; note 3	0.3	1.0	–	mA
I _{OH}	HIGH level output current	V _{OH} > 3 V	–1.5	–9.0	–	mA
Regulator 1 (I_{REG1} = 5 mA unless otherwise specified)						
V _{REG1}	output voltage off	V _{sc} > 2.1 V	–	1	400	mV
V _{REG1}	output voltage	0.5 V ≤ I _{REG1} ≤ 250 mA	8.2	8.5	8.8	V
		10 V ≤ V _P ≤ 18 V	8.2	8.5	8.8	V
ΔV _{REG1}	line regulation	10 V ≤ V _P ≤ 18 V	–	–	50	mV
ΔV _{REGL1}	load regulation	0.5 mA ≤ I _{REG1} ≤ 250 mA	–	–	50	mV
SVRR1	supply voltage ripple rejection	f = 200 Hz; 2 V (p-p)	60	–	–	dB
V _{REGd1}	drop-out voltage	I _{REG1} = 250 mA	–	–	0.4	V
I _{REGm1}	current limit	V _{REG1} > 7 V; note 4	0.4	–	1.2	A
I _{REGsc1}	short-circuit current	R _L ≤ 0.5 Ω; note 4	–	250	–	mA
Regulator 2 (I_{REG2} = 10 mA unless otherwise specified)						
V _{REG2}	output voltage off	V _{sc} > 2.1 V	–	1	400	mV
V _{REG2}	output voltage	0.5 V ≤ I _{REG2} ≤ 140 mA	4.8	5.0	5.2	V
		8 V ≤ V _P ≤ 18 V	4.8	5.0	5.2	V
ΔV _{REG2}	line regulation	8 V ≤ V _P ≤ 18 V	–	–	50	mV
ΔV _{REGL2}	load regulation	0.5 mA ≤ I _{REG2} ≤ 140 mA	–	–	50	mV
SVRR2	supply voltage ripple rejection	f = 200 Hz; 2 V (p-p)	60	–	–	dB
V _{REGd2}	drop-out voltage	I _{REG2} = 140 mA	–	1.2	–	V
I _{REGm2}	current limit	V _{REG2} > 4.5 V; note 4	200	–	600	mA
I _{REGsc2}	short-circuit current	R _L ≤ 0.5 Ω; note 4	–	130	–	mA

Multiple output voltage regulator

TDA3602

SYMBOL	PARAMETER	CONDITIONS	MIN.	TYP.	MAX.	UNIT
Regulator 3 ($I_{REG3} = 5 \text{ mA}$ unless otherwise specified)						
V_{REG3}	output voltage	$0.5 \text{ mA} \leq I_{REG3} \leq 50 \text{ mA}$	4.8	5.0	5.2	V
		$7 \text{ V} \leq V_P \leq 18 \text{ V}$	4.8	5.0	5.2	V
		$18 \leq V_P \leq 50 \text{ V}$	4.8	5.0	5.2	V
ΔV_{REGL3}	output voltage	sleep mode; $I_{REG3} \leq 10 \text{ mA}$; note 2	4.5	5.0	5.5	V
I_{LO1}	leakage output current	$V_P = 0$; $V_{bu} = 6 \text{ V}$; $V_{REG3} = 6 \text{ V}$	–	–	–1	μA
ΔV_{REG3}	line regulation	$7 \text{ V} \leq V_P \leq 18 \text{ V}$	–	–	50	mV
ΔV_{REGL3}	load regulation	$0.5 \text{ mA} \leq I_{REG3} \leq 50 \text{ mA}$	–	–	50	mV
SVRR3	supply voltage ripple rejection	$f = 200 \text{ Hz}$; 2 V (p-p)	60	–	–	dB
V_{REGd3}	drop-out voltage	$I_{REG3} = 50 \text{ mA}$; note 5	–	–	0.4	V
I_{REGm3}	current limit	$V_{REG3} > 4.5 \text{ V}$; note 6	140	–	500	mA
Switch						
V_{swd}	drop-out voltage	$I_{sw} = 50 \text{ mA}$	–	–	0.45	V
I_{swm}	maximum current		140	–	–	mA

Notes

1. Minimum operating voltage only if V_P has exceeded 8 V.
2. In the sleep mode, Regulators 1 and 2 are off. In the coma mode, the state control circuit is also switched off, to make the quiescent current as low as possible.
3. Hold circuit can sink this current in the RESET state and the ON state.
4. The foldback current protection limits the dissipated power at short-circuit (see Fig.5).
5. The drop-out voltage of Regulator 3 is measured between V_{bu} and V_{REG3} (pins 8 and 7).
6. At current limit, I_{REGm} is held constant (behaviour in accordance with the broken line in Fig.5).

Multiple output voltage regulator

TDA3602

Table 1 State control pin.

V _{P1} SCHMITT TRIGGER IS TRUE				
STATE	REG3 (5 V)	REG1 + REG2	RESET	REMARKS
Coma	LOW current	off	0	stabilizer consumes low quiescent current; state control circuit is switched off to lower the quiescent current
Sleep	LOW current	off	0	state control circuit on
Wake	HIGH current	off	0	CPU in sleep mode
Reset	HIGH current	off	1	CPU called up
On	HIGH current	on	1	normal operation
Power on	HIGH current	off	1	V _{P1} rises from 0 to 8.5 V or higher (first start-up)
Power off	off	off	0	V _{P2} falls from V _P to less than 3 V (V _{REG3} = 2.5 V)

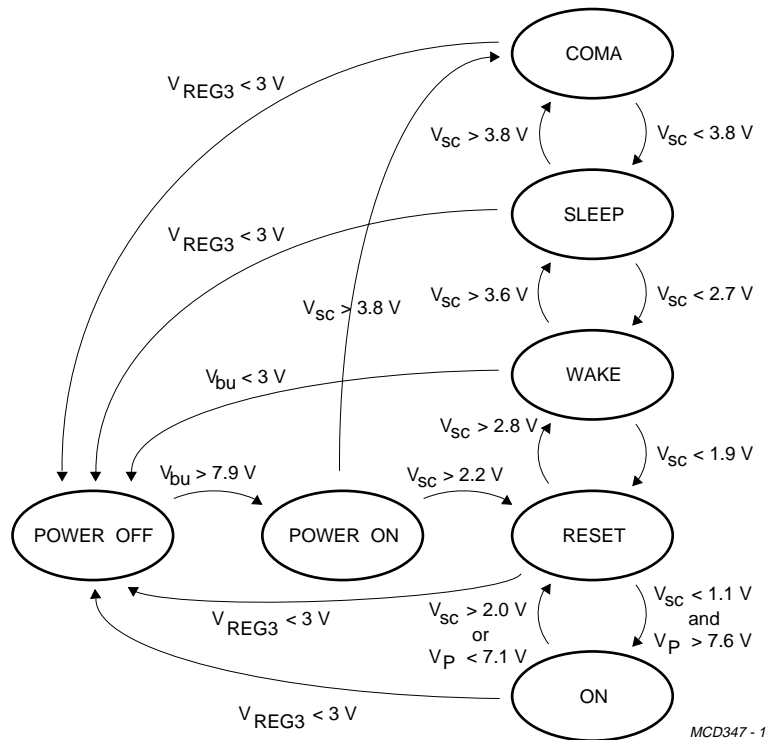

V_{bu} = back-up voltage.
 V_{sc} = state control voltage.
 V_{REG3} = Regulator 3 output voltage.

Fig.3 State diagram.

Multiple output voltage regulator

TDA3602

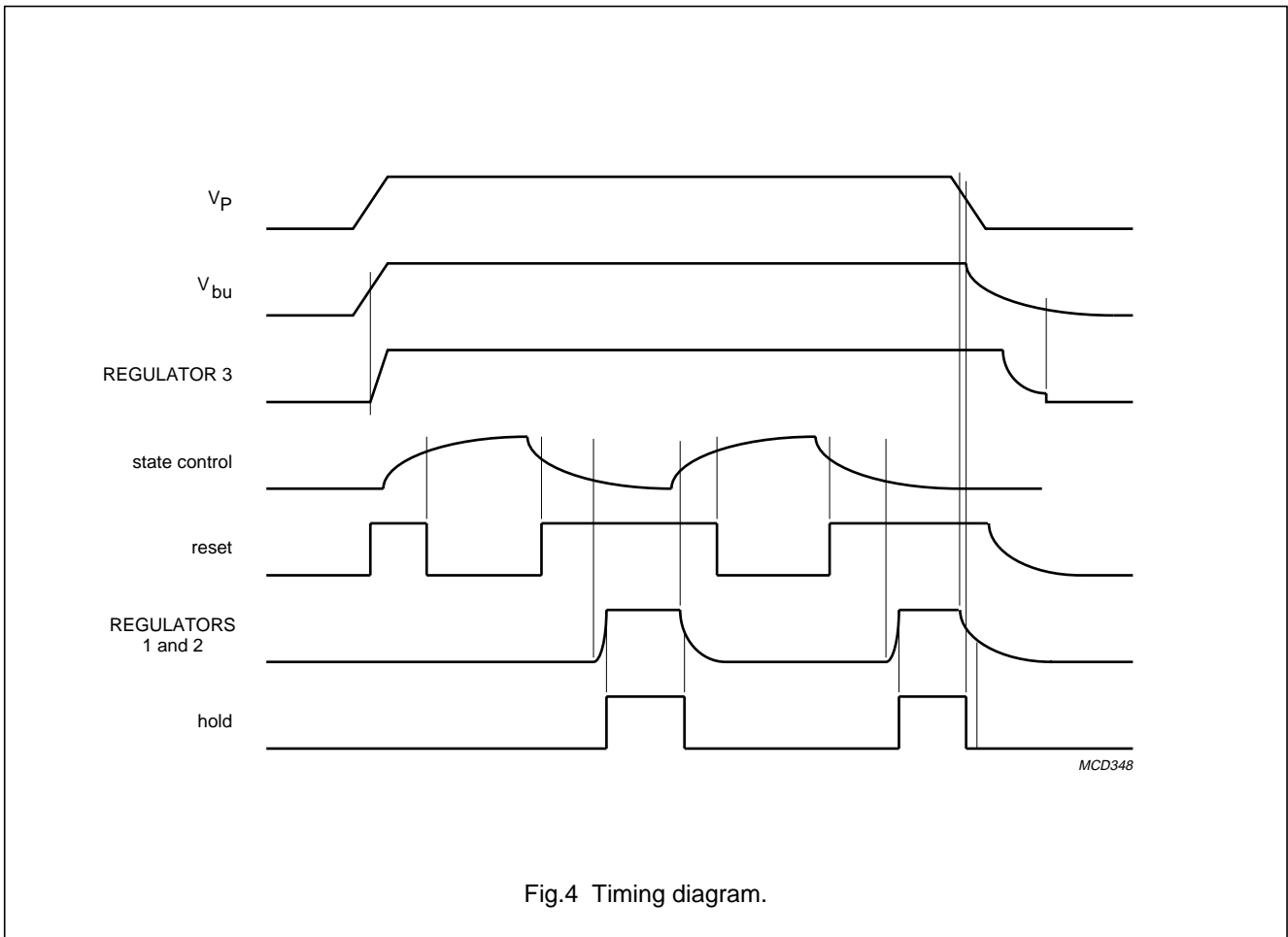

Fig.4 Timing diagram.

Table 2 Logic table HOLD function.

INPUTS FOR HOLD (note 1)					OUTPUT
V _{BU}	V _P SCHMITT TRIGGER	ON STATE	REG1	REG2	HOLD
1	0	X	0	0	0
0	1	X	0	0	0
1	1	0	0	0	0
1	1	1	0	X	0
1	1	1	X	0	0
1	1	1	1	1	1

Note

1. 0 = off; 1 = on; X = don't care.

Multiple output voltage regulator

TDA3602

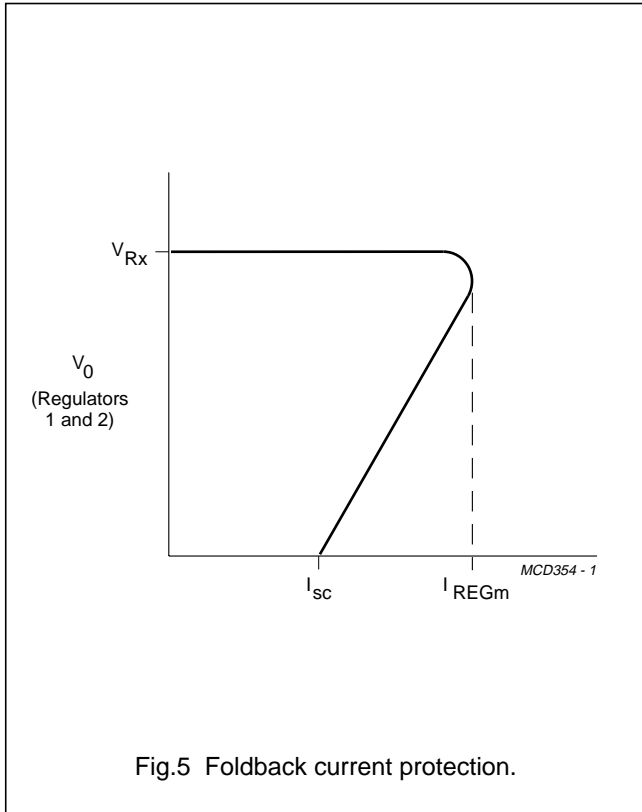

Fig.5 Foldback current protection.

QUALITY SPECIFICATION

Quality in accordance with UZW-BO/FQ-0601.

TEST INFORMATION

The outputs of the regulators are measured by means of a selector switch (one by one). In addition, switch SW2 is only closed when V_{bu} is greater than V_P ; then the internal switch of the TDA3602 is opened. V_{bu} (pin 8) can only withstand a 50 V load dump pulse when switch SW2 is kept open or when switch SW2 is replaced by a 100 Ω resistor.

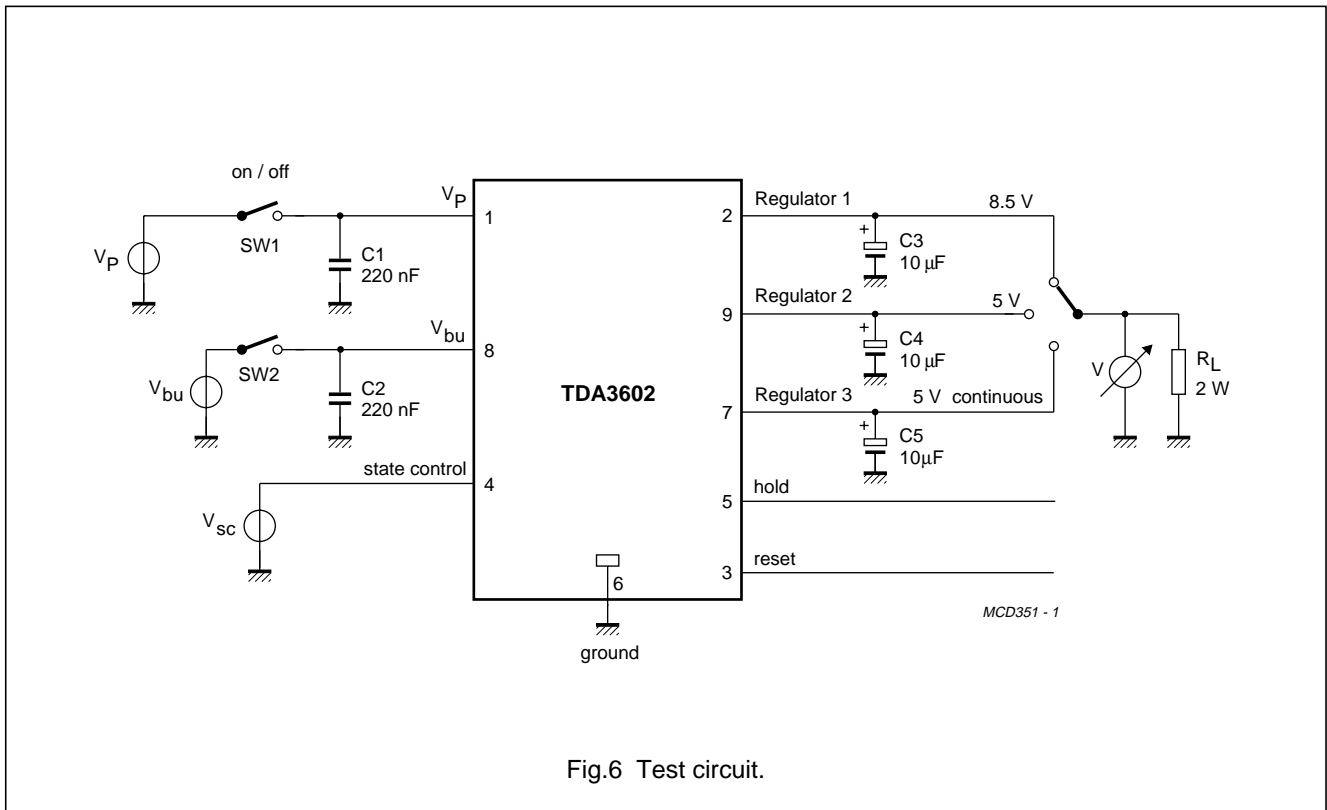

Fig.6 Test circuit.

Multiple output voltage regulator

TDA3602

APPLICATION INFORMATION

Noise

Table 3 Noise at regulator outputs dependent on capacitive load (C_L).

REGULATOR (NOTE 1)		C_L		
REG	I_L	10 μF	47 μF	220 μF
1	150 mA	800 μV	220 μV	160 μV
2	100 mA	500 μV	115 μV	
3	50 mA	350 μV	190 μV	

Note

1. Regulators loaded with 100mA; noise in μV RMS (B = 10 Hz to 1 MHz).

The available noise at the output of the regulators depends on the bandwidth of the regulators, which can be adjusted by means of the load capacitors. The noise figures are given in Table 3.

Although stability is guaranteed when C_L is higher than 10 μF (over temperature range) with $\tan(\phi) = 1$ in the frequency range 1 kHz to 20 kHz, it is recommended to use a 47 μF load capacitor for Regulators 1 and 2. When a microprocessor is supplied by Regulator 3 much noise can be produced by this microprocessor. This noise is not influenced by increasing the load capacitor of Regulator 3.

The noise on the supply line depends on the supply capacitor. When a high frequency capacitor of 220 nF with an electrolytic capacitor of 100 μF in parallel is placed directly over pin 1 (V_P) and pin 6 (ground) the noise is minimized.

The stabilizer is in 'power on' after the supply is reconnected ($V_{bu} > 7.9 \text{ V}$) and $0.1 < V_{sc} < 2.2 \text{ V}$.

Application circuits

STABILIZER WITHOUT MICROPROCESSOR 1

The low end application is illustrated in Fig.7. When switch SW1 is closed, a pulse is generated at the state control input by C5 and R1, and the regulator is switched from power off to the on mode (all three regulators are on). The HOLD signal can be used to control the mute signal for the power amplifiers. This signal is HIGH when all the regulators are in regulation and V_{P1} Schmitt trigger is true.

STABILIZER WITHOUT MICROPROCESSOR 2

Fig.8 illustrates the application circuit for a low end radio set with push switches when no microprocessor is used. The stabilizer can be switched to the on mode by pressing switch SW1. In this mode, Regulators 1 and 2 are switched on, so transistor T1 takes over from switch SW1. The stabilizer can only be switched off by connecting the base of T1 to ground (SW1 not pressed). This can be achieved by pressing switch SW2.

The hold signal is only HIGH when the device is in the on mode and both V_P and the regulators are available, so that this signal can be used to control the power stages (mute). During a fault condition, this signal turns LOW immediately.

When the stabilizer is connected to the supply for the first time, the initial state will be the power-on stage, so Regulators 1 and 2 are not switched on.

STABILIZER USED WITH MICROPROCESSOR

For a good understanding of the high end application, shown in Fig.10, consult the flow chart of Fig.9.

When the set is off, a reset can be generated by connecting the set to the supply for the first time (stabilizer in power-on), or by pressing any key on the key matrix (stabilizer in reset mode). When the reset is generated, the stabilizer is held in the reset mode for a short period by T1. The microprocessor has to take over control by making reset mode equal to 0. The microprocessor can then proceed with the initializing process. After this action, the microprocessor has to check if the correct key has been pressed. If so, the radio can be switched on by making on equal to 0; if not, the microprocessor must switch the device to the coma mode again, by making reset mode and on both equal to 1; (wake mode is entered after a short time constant, determined by $R1 \times C7 \times \text{constant}$), and switch itself to sleep mode.

When the reset is generated for the first time (power-on mode), the mode of the device can be detected by the hold signal. If on = 0 and hold remains LOW, then the microprocessor is in the power-on mode. In this event, the microprocessor must go to the switch-off routine (making on and reset mode both equal to 1).

Multiple output voltage regulator

TDA3602

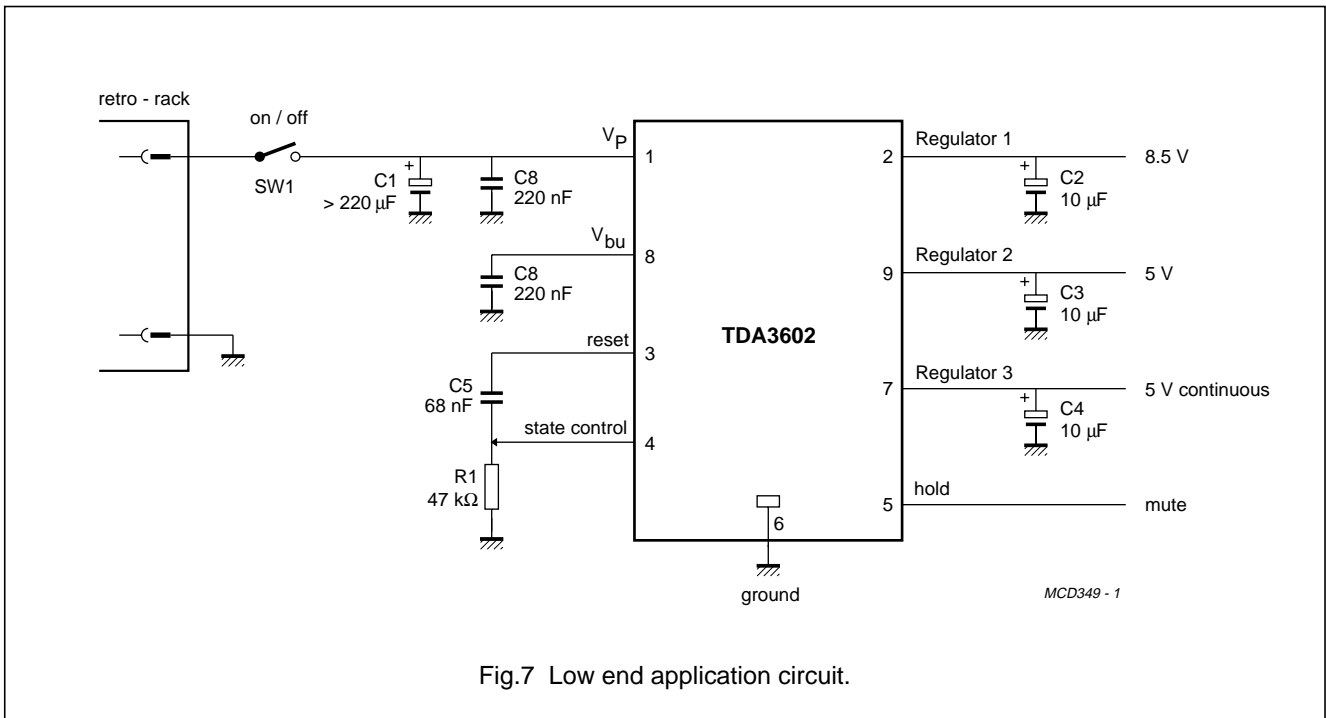

Fig.7 Low end application circuit.

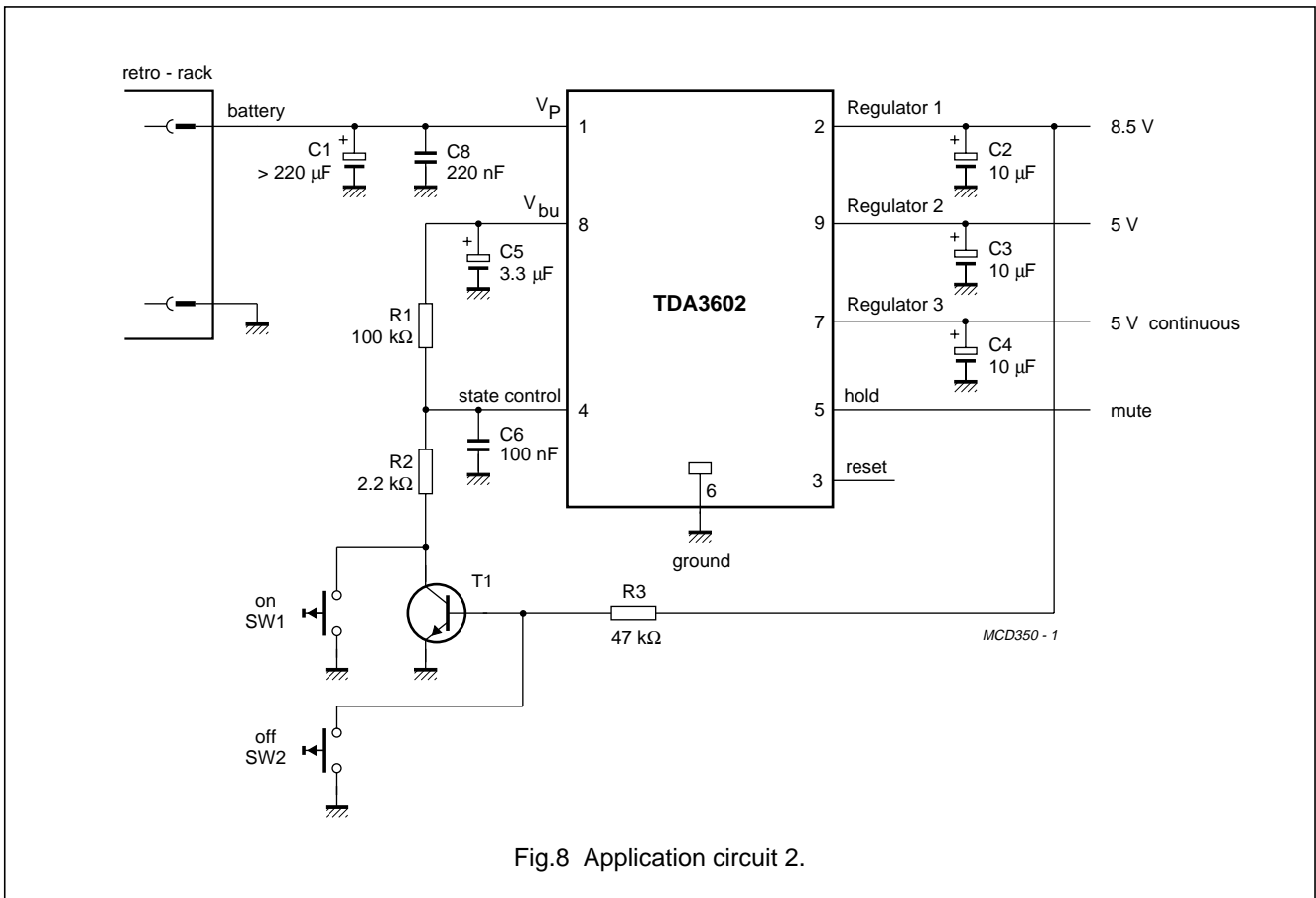
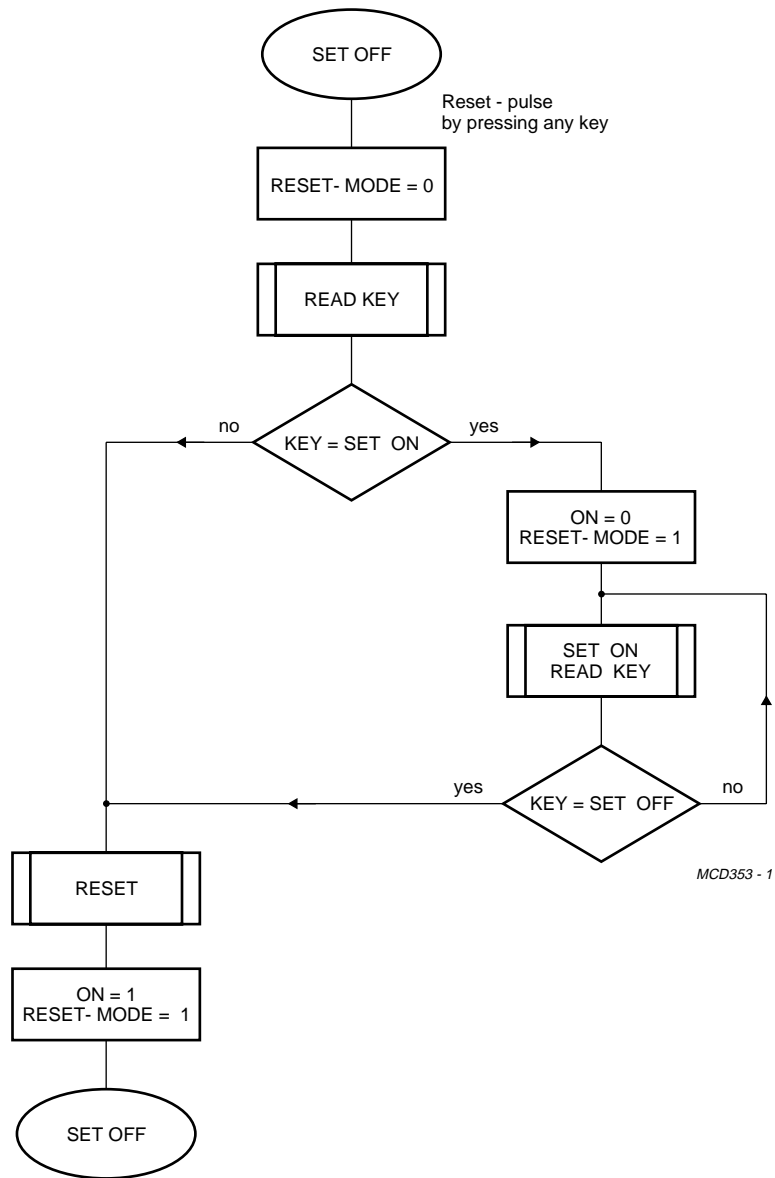

Fig.8 Application circuit 2.

Multiple output voltage regulator

TDA3602



MCD353 - 1

Fig.9 Flow chart for high end application.

Multiple output voltage regulator

TDA3602

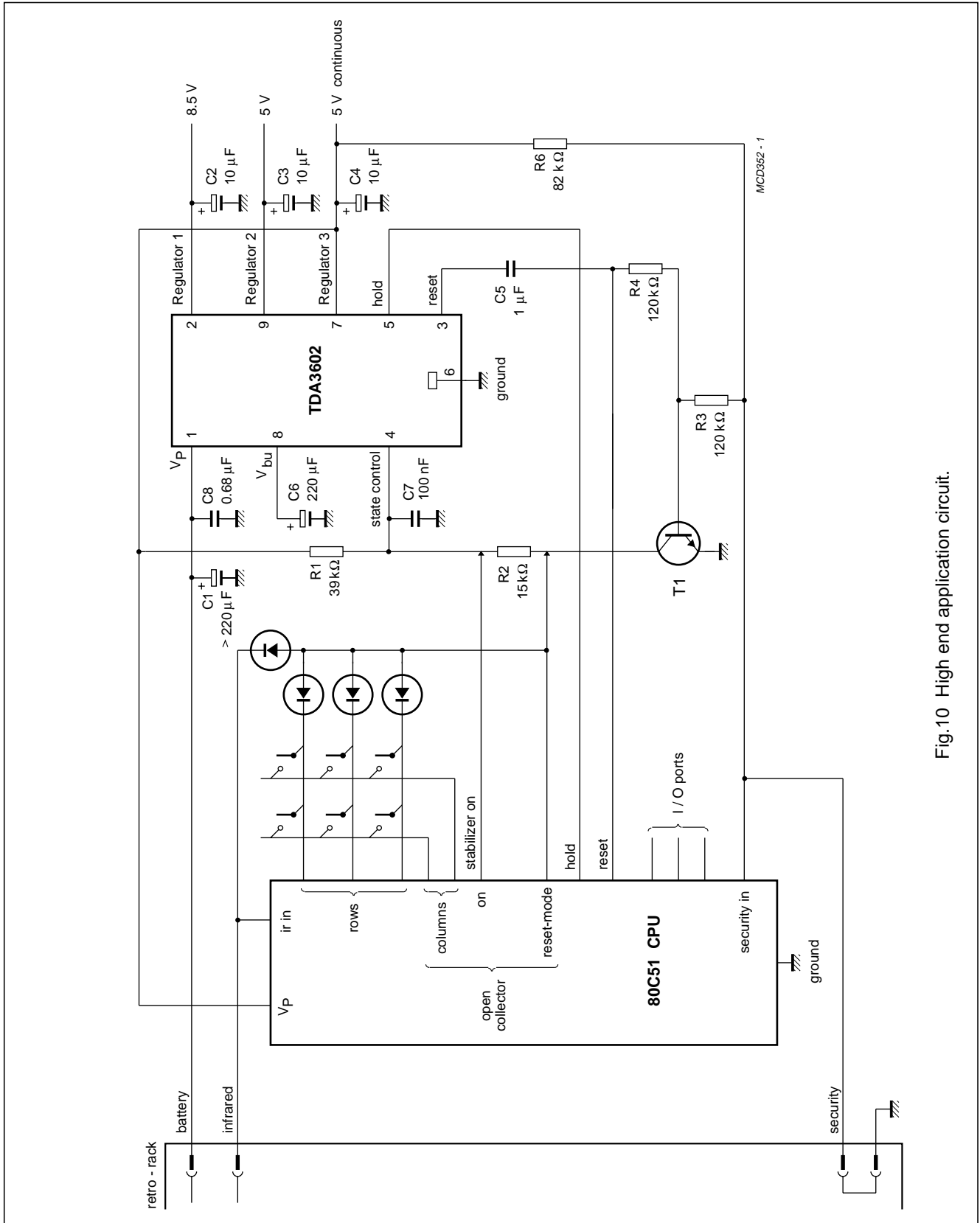

Fig.10 High end application circuit.

Multiple output voltage regulator

TDA3602

Example of a modern car radio design with the TDA3602

DESIGN CONSIDERATIONS

A modern car radio set meets the following design considerations:

1. Semi on/off logic. The radio set has to switch on/off by pressing the on/off key or by switching the ignition
2. Security code check
3. Low quiescent current in standby (this means that the microprocessor is off when the set is off)
4. The set must recover the state it had before an engine start or load dump
5. Apart from HOLD, RESET and V_P only two more I/O lines are used for full on/off logic
6. Supply by 1 or 2 supply lines
7. Radio Data System (RDS) should be implemented in the set, but this is not a regulator problem
8. Lights must switch off during load dump

Although the TDA3602 is designed only to be supplied by a continuous supply (battery), it is also possible to use both a continuous and a switchable supply (ignition). The ignition can be used to supply also the TDA3602, although in this event additional circuitry is needed.

APPLICATION CIRCUIT WITH (SEMI-)FULL ON/OFF LOGIC

The application circuit of Fig.11 will meet all the above mentioned design considerations. Three circuit parts can be distinguished:

Reset circuitry

A reset is required to call-up the microprocessor when it is switched to the sleep mode or the power-on reset (first initialization of the microprocessor). To achieve this, three different types of resets should be generated:

1. When the set has been disconnected from the supply, the microprocessor must be initialized at connection to the supply for the first time. The output ports of the microprocessor are in a random state. To ensure correct initialization, a reset has to be generated. This is accomplished by the power-on state of the TDA3602. In this state the reset output is HIGH and Regulators 1 and 2 are disabled (despite the voltage on the state control pin V_{SC} being below 1.1 V). Only after the voltage on the state control pin has risen above 2.2 V can Regulators 1 and 2 be switched on again by pulling the state control pin below 1.1 V.
2. In the sleep mode the microprocessor should be called up by pressing the on/off key (normal off condition). Now the reset is also generated by the RESET output of the TDA3602. This reset output will go HIGH when V_{SC} decreases from the value V_{REG3} to below 1.9 V.
3. At fault conditions (V_P below 7.1 V, $V_{REG1} < V_{REG1 \text{ nominal}} - 0.3$ V or $V_P > 1.8$ V), HOLD drops to logic 0 and the microprocessor switches off the set. In accordance with the design considerations is that the mode of operation must switch to the state it was in before an engine start or load dump occurred. To achieve this the HOLD output of the TDA3602 can be used to generate a reset pulse (only when V_{SC} remains below 1.1 V).

The RESET and HOLD outputs of the TDA3602 are combined to generate the reset pulses. The pulses are created by differentiating the outputs, using capacitors C8 and C9. The reset pulses are added by means of the diodes D2 and D3. The time constants are:

- $t_{res(res)} = 3 \times R7 \times C8 = 3 \times 10 \text{ k}\Omega \times 1\mu\text{F} = 30 \text{ ms}$
on/off button S1 should be pressed for at least 30ms, before the microprocessor will see this
- $t_{res(hold)} = 3 \times R7 \times C9 = 5.4 \text{ ms}$
- $t_{res(dis)} = 3 \times R8 \times C8 = 140 \text{ ms}$
- $t_{res(hold(dis))} = 3 \times R9 \times C9 = 25 \text{ ms}$
the microprocessor has to wait and check if HOLD remains LOW for at least 25 ms before it switches off; now it is certain that a correct reset will occur to wake up the microprocessor again.

Multiple output voltage regulator

TDA3602

A reset by the hold function can only be created when the state control pin remains LOW. This is accomplished by means of transistor T1 when Port P0,0 is high ohmic. Because of resistors R2, R3 and R5 the transistor will switch off when V_{ignition} falls below a level of 5.0 V. During an engine start, when V_{ignition} reaches voltages as low as 5 V, the transistor will switch off. Regulators 1 and 2 are already switched off by means of the V_P Schmitt-trigger, causing the HOLD output to go LOW. When V_{ignition} again increases the transistor will be switched on again (Port P0,0 has to be open = logic 1), thereby switching the state control pin to 0 V. As V_{ignition} continues to increase above 7.6 V (V_{rise} of the V_{P1} Schmitt-trigger) Regulators 1 and 2 will again switch on causing the HOLD output to go HIGH, creating a new reset pulse.

The set can also be switched off by opening the ignition key, causing transistor T1 to switch off. When the ignition key is closed again, the set will restart to the original situation that existed before the ignition key was opened.

The charge time of C6 equals $3 \times R4 \times C6 = 14\text{ms}$. This is less than the reset time $t_{\text{res(reset)}}$. To avoid the TDA3602 switching to coma mode before the microprocessor is awakened, a double function has been given to T1. During a reset pulse T1 is on (because of resistor R7), thus V_{sc} will remain 0 V provided a reset occurs. After the reset pulse has disappeared, the microprocessor is able to fully control V_{sc} by mean of Port P0,0 or Port P1,1.

Security code circuitry

When the set is off and it is pulled out of RETRACK, $\times 3$ and $\times 4$ are disconnected thereby switching the base of transistor T1 to the output voltage of Regulator 3 (using resistors R5 and R6). Transistor T1 is starting to conduct and a RESET pulse is generated. The microprocessor is activated and checks if Port P1,0 = logic 1. If this is so, the microprocessor knows that the set is pulled out of RETRACK and that time is limited to finish the program correctly (because the microprocessor is operating on the charge of capacitor C3). The security flag has to be set in an EEPROM and the microprocessor can switch to power-down before Regulator 3 switches to power-off.

Another possibility is that the set was running and pulled out of RETRACK. Now a hold is generated, and the hold interrupt routine has to check the security in Port P1,0.

R6 is an internal resistor in the microprocessor. An external resistor limits however the spread.

Bulb circuitry

The lights are switched on provided the RESET output of the TDA3602 is HIGH. This normally occurs when the set is switched on. Only at first connection (power-off) will the RESET output be HIGH when the set is off. In this event the lights are also switched on. This is not a problem because the required time for initializing the microprocessor will be very short.

When a load dump occurs, the RESET output will go LOW, disabling the lights. With the aid of this feature it is possible to prevent the light bulbs being damaged at load dump.

Noise.

Regulators 1 and 2 are loaded with a $47 \mu\text{F}/16 \text{ V}$ load capacitor because of output noise. With this value the output noise will be lower than $220 \mu\text{V}$ for Regulator 1 and lower than $120 \mu\text{V}$ for Regulator 2 (see Table 3 and associated text).

To minimize the noise on the supply line, capacitors C1 and C2 should be placed as close as possible across the supply and ground pins of the TDA3602.

Timing diagram

In the timing diagram all of the situations which can occur are shown (see Fig.12). A HIGH of switch S1 indicates that S1 is pressed. A HIGH on Port P0,0 indicates that Port P0,0 is high ohmic (Port P0 is an open-collector output). If no open-collector output is available another port can be used, but an extra diode has to be added in series with this port to prevent T1 being switched on by this port. A HIGH for the microprocessor indicates that the microprocessor is operating, a LOW indicates that the microprocessor is in standby mode.

The following situations are covered in the timing diagram:

1. Initialization of the microprocessor (TDA3602 in power-off mode)
2. Switching the ignition with the set off (Port P0,0 = logic 0)
3. Switching the set on/off/on by pressing S1 sequentially (ignition available)
4. Switching behaviour at engine start and load dump (set on)
5. Switching the set off and on again by switching the ignition.

Multiple output voltage regulator

TDA3602

The timing diagram can only be understood after a thorough investigation of the flow charts (see section Flow chart semi on/off logic with security code). Furthermore short and long RESET pulses can be seen (see Fig.12).

Flowchart semi on/off logic with security code

This section describes the software for controlling the TDA3602 (semi on/off logic). A "o" in the flowchart flow diagram Fig.13, indicates that the port mentioned is switched as an output. A "1" indicates that the port mentioned is switched as an input (temporarily).

The flowchart of figure 13 can be used for semi on/off logic.

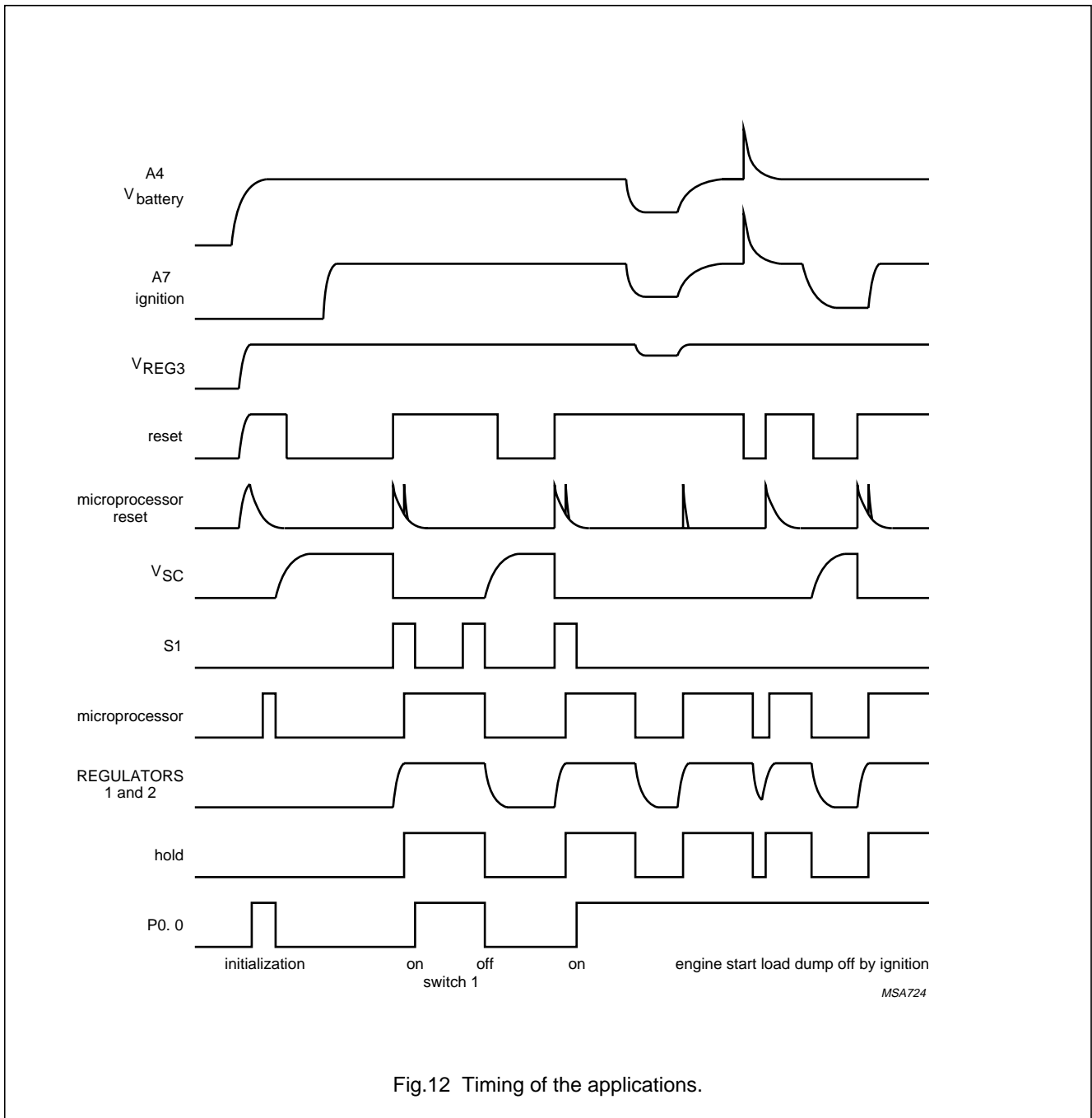

Fig.12 Timing of the applications.

Multiple output voltage regulator

TDA3602

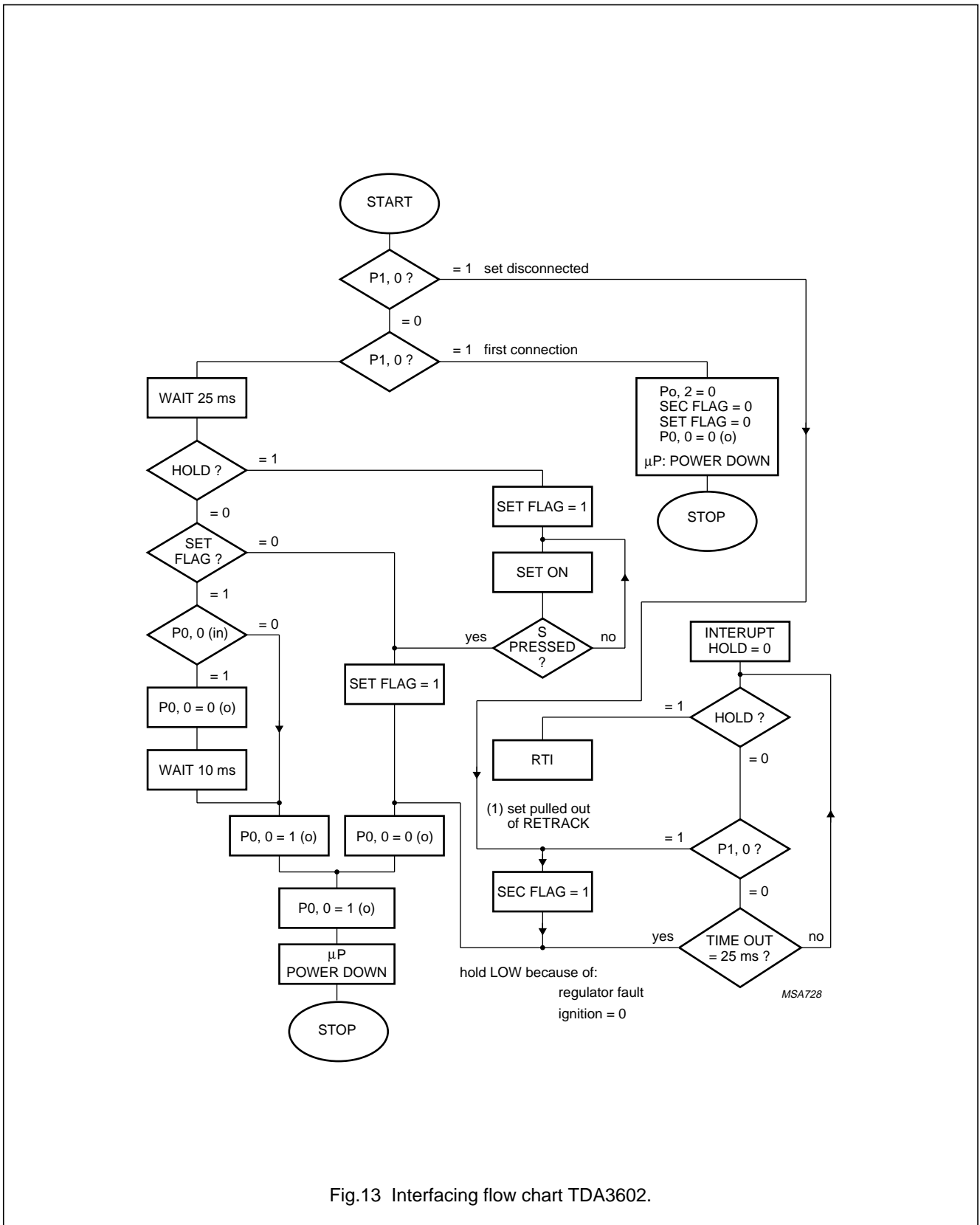

Fig.13 Interfacing flow chart TDA3602.

Multiple output voltage regulator

TDA3602

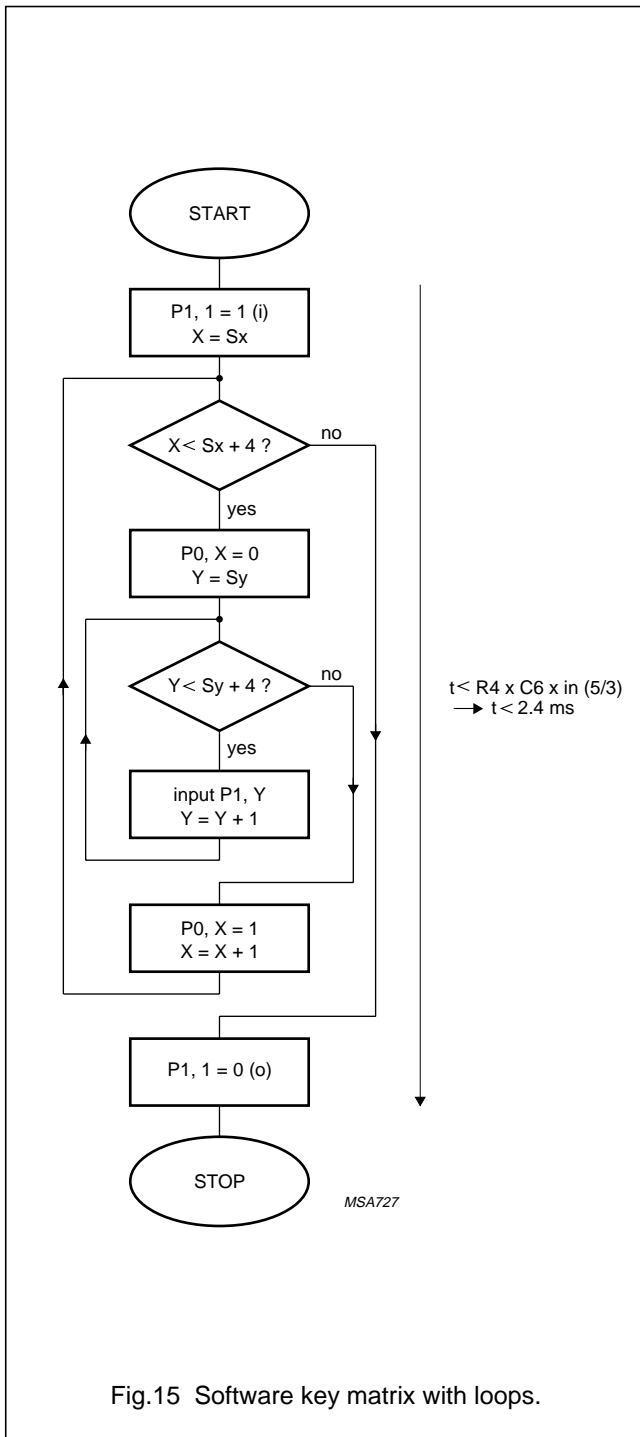

Fig.15 Software key matrix with loops.

FULL ON/OFF LOGIC

Using application circuit Fig.14, full on/off logic can be achieved. Also extra software loops are required to enable the set when ignition is off. The set can be controlled by Port P1,1 if the ignition is off (thus no extra I/O ports of the microprocessor are required for full on/off logic).

Because Port P1,1 is a part of the key matrix the complete key-scan loop must be finished within less than $0.5 \times R4 \times C6 = 2.4$ ms, otherwise the TDA3602 will enter the reset state and Regulators 1 and 2 are switched off during this key-scan loop. When the time of the complete loop is within 2.4 ms the V_{sc} will remain below 2 V (thus Regulators 1 and 2 remain on).

It is also possible to switch Port P1,1 during the key-scan loop sequentially from output (logic 0) to input. If this is achieved within a time period of 1 ms, V_{sc} cannot become HIGH long enough to switch Regulators 1 and 2 off.

When ignition is available, transistor T1 overrules Port P1,1. In this event no variation on V_{sc} is seen during the key-scan loop.

The flow chart presented in Fig.15 is only required for the full on/off logic application of Fig.14.

The complete key-scan routine must be finished within 2.4 ms (when ignition is off) and that the key-scan routine has to end with a statement $P1,1 = \text{logic } 0$. In the flow chart of the key-scan routine, Sx is the start value of the rows and Sy the start value of the columns. With $Sx = 1$ and $Sy = 1$, one '0' is shifted on the output ports P0,1 to P0,5 and the input ports P1,1 to P1,5 are being read sequentially per shift action.

Connections between microprocessor and Regulator 2 supplied

When digital ICs, supplied by Regulator 2, are connected to I/O ports (especially Ports 1 and 2), special attention in the software has to be taken to avoid currents flowing from Regulator 3 to Regulator 2. Because of ESD diodes in digital ICs a current can flow from an output port (which is in a high state) through the ESD diode into Regulator 2. This will cause an increase in the quiescent current of the set. The recommended action to avoid this problem is to switch the specific I/O ports to logic 0.

Multiple output voltage regulator

TDA3602

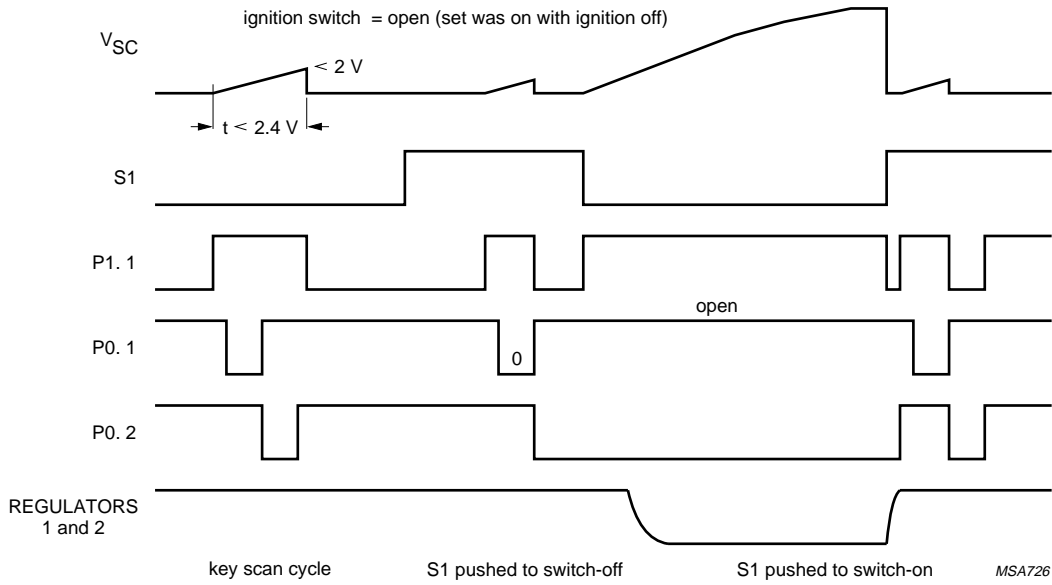

Fig.16 Timing key matrix.

Multiple output voltage regulator

TDA3602

PACKAGE OUTLINE

SIL9MPF: plastic single in-line medium power package with fin; 9 leads

SOT110-1

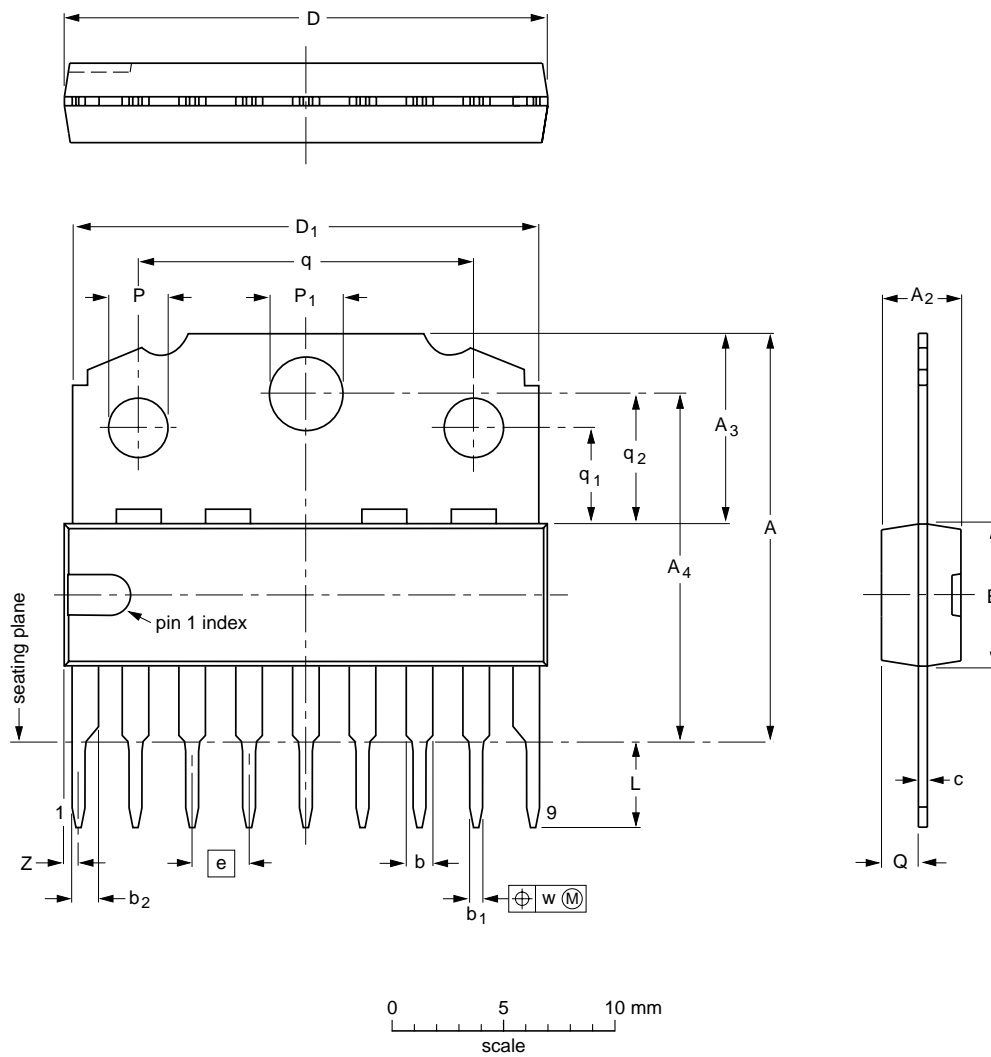

DIMENSIONS (mm are the original dimensions)

UNIT	A	A ₂ max.	A ₃	A ₄	b	b ₁	b ₂	c	D ⁽¹⁾	D ₁	E ⁽¹⁾	e	L	P	P ₁	Q	q	q ₁	q ₂	w	Z ⁽¹⁾ max.
mm	18.5 17.8	3.7	8.7 8.0	15.8 15.4	1.40 1.14	0.67 0.50	1.40 1.14	0.48 0.38	21.8 21.4	21.4 20.7	6.48 6.20	2.54	3.9 3.4	2.75 2.50	3.4 3.2	1.75 1.55	15.1 14.9	4.4 4.2	5.9 5.7	0.25	1.0

Note

1. Plastic or metal protrusions of 0.25 mm maximum per side are not included.

OUTLINE VERSION	REFERENCES				EUROPEAN PROJECTION	ISSUE DATE
	IEC	JEDEC	EIAJ			
SOT110-1						92-11-17 95-02-25

Multiple output voltage regulator

TDA3602

SOLDERING

Introduction

There is no soldering method that is ideal for all IC packages. Wave soldering is often preferred when through-hole and surface mounted components are mixed on one printed-circuit board. However, wave soldering is not always suitable for surface mounted ICs, or for printed-circuits with high population densities. In these situations reflow soldering is often used.

This text gives a very brief insight to a complex technology. A more in-depth account of soldering ICs can be found in our "IC Package Databook" (order code 9398 652 90011).

Soldering by dipping or by wave

The maximum permissible temperature of the solder is 260 °C; solder at this temperature must not be in contact with the joint for more than 5 seconds. The total contact time of successive solder waves must not exceed 5 seconds.

The device may be mounted up to the seating plane, but the temperature of the plastic body must not exceed the specified maximum storage temperature ($T_{stg\ max}$). If the printed-circuit board has been pre-heated, forced cooling may be necessary immediately after soldering to keep the temperature within the permissible limit.

Repairing soldered joints

Apply a low voltage soldering iron (less than 24 V) to the lead(s) of the package, below the seating plane or not more than 2 mm above it. If the temperature of the soldering iron bit is less than 300 °C it may remain in contact for up to 10 seconds. If the bit temperature is between 300 and 400 °C, contact may be up to 5 seconds.

DEFINITIONS

Data sheet status	
Objective specification	This data sheet contains target or goal specifications for product development.
Preliminary specification	This data sheet contains preliminary data; supplementary data may be published later.
Product specification	This data sheet contains final product specifications.
Limiting values	
Limiting values given are in accordance with the Absolute Maximum Rating System (IEC 134). Stress above one or more of the limiting values may cause permanent damage to the device. These are stress ratings only and operation of the device at these or at any other conditions above those given in the Characteristics sections of the specification is not implied. Exposure to limiting values for extended periods may affect device reliability.	
Application information	
Where application information is given, it is advisory and does not form part of the specification.	

LIFE SUPPORT APPLICATIONS

These products are not designed for use in life support appliances, devices, or systems where malfunction of these products can reasonably be expected to result in personal injury. Philips customers using or selling these products for use in such applications do so at their own risk and agree to fully indemnify Philips for any damages resulting from such improper use or sale.