

DATA SHEET

TDA3615J Multiple voltage regulator

Preliminary specification
File under Integrated Circuits, IC01

1998 Jun 23

Multiple voltage regulator

TDA3615J

FEATURES

General

- Six voltage regulators
- Five microprocessor controlled regulators (regulators 2 to 6)
- Regulator 1 and reset operate during load dump and thermal shutdown
- Low reverse current of regulator 1
- Very low quiescent current when regulators 2 to 6 and power switches are switched off ($V_{I(iq)} = 0\text{ V}$)
- Reset output
- Adjustable display regulator
- High ripple rejection
- Three power switches
- Low noise for regulators 2 to 6.

Protections

- Reverse polarity safe (down to -18 V without high reverse current)
- Able to withstand voltages up to 18 V at the output (supply line may be short-circuited)
- ESD protected on all pins
- Thermal protection
- Load dump protection
- Foldback current limit protection (except for regulator 2)
- The regulator outputs and the power switches are DC short-circuited safe to ground and V_{bat} .

GENERAL DESCRIPTION

The TDA3615J is a multiple output voltage regulator with power switches, intended for use in car radios with or without a microprocessor. It contains:

- One fixed voltage regulator (regulator 1) intended to supply a microprocessor, that also operates during load dump and thermal shutdown
- 5 power regulators supplied by $V_{I(iq)}$
- 3 power switches with protections
- 3 enable inputs for selecting regulators 2 to 6 and the three power switches
- Very low quiescent current of typical $110\text{ }\mu\text{A}$.

ORDERING INFORMATION

TYPE NUMBER	PACKAGE		
	NAME	DESCRIPTION	VERSION
TDA3615J	DBS17P	plastic DIL-bent-SIL power package; 17 leads (lead length 12 mm)	SOT243-1

Multiple voltage regulator

TDA3615J

QUICK REFERENCE DATA

SYMBOL	PARAMETER	CONDITIONS	MIN.	TYP.	MAX.	UNIT
Supply						
$V_{bat/I(i)}$	supply voltage	regulators on	11	14.4	18	V
	operating	regulator 1 on	3.5	14.4	18	V
	operating	$t \leq 10$ minutes	–	–	30	V
	jump start	$t \leq 50$ ms; $t_r \geq 2.5$ ms	–	–	50	V
I_q	quiescent supply current	$V_{bat} = 14.4$ V; $V_{I(i)} < 1$ V; note 1	–	110	250	μ A
		$V_{bat} = V_{I(i)} = 14.4$ V; selector inputs 0,0,0 (state 3 in Table 1); note 1	–	125	–	μ A
Voltage regulators						
$V_{O(REG1)}$	output voltage regulator 1 (5 V standby)	$0.5 \text{ mA} \leq I_{REG1} \leq 50 \text{ mA}$	4.75	5.0	5.25	V
$V_{O(REG2)}$	output voltage regulator 2 (filament)	$0.5 \text{ mA} \leq I_{REG2} \leq 300 \text{ mA}$	2.7	2.85	3.0	V
$V_{O(REG3)}$	output voltage regulator 3 (5 V logic)	$0.5 \text{ mA} \leq I_{REG3} \leq 450 \text{ mA}$	4.75	5.0	5.25	V
$V_{O(REG4)}$	output voltage regulator 4 (synthesizer)	$0.5 \text{ mA} \leq I_{REG4} \leq 100 \text{ mA}$	9.0	9.5	10.0	V
$V_{O(REG5)}$	output voltage regulator 5 (AM)	$0.5 \text{ mA} \leq I_{REG5} \leq 150 \text{ mA}$	9.0	9.5	10.0	V
$V_{O(REG6)}$	output voltage regulator 6 (FM)	$0.5 \text{ mA} \leq I_{REG6} \leq 150 \text{ mA}$	9.0	9.5	10.0	V
Power switches						
V_{d1}	drop-out voltage switch 1 (antenna)	$I_{SW1} = 0.55 \text{ A}$	0.1	0.45	1.6	V
I_M	peak current switch 1	$t < 1 \text{ s}$	1.7	1.9	–	A
V_{d2}	drop-out voltage switch 2 (media)	$I_{SW2} = 1 \text{ A}$	–	0.5	1.0	V
V_{clamp2}	clamping voltage switch 2		–	15.0	16	V
V_{d3}	drop-out voltage switch 3 (display)	$I_{SW3} = 0.35 \text{ A}$	–	0.5	1.0	V
V_{clamp3}	clamping voltage switch 3		–	15.2	16	V

Note

1. The quiescent current is measured when $R_L = \infty$.

Multiple voltage regulator

TDA3615J

BLOCK DIAGRAM

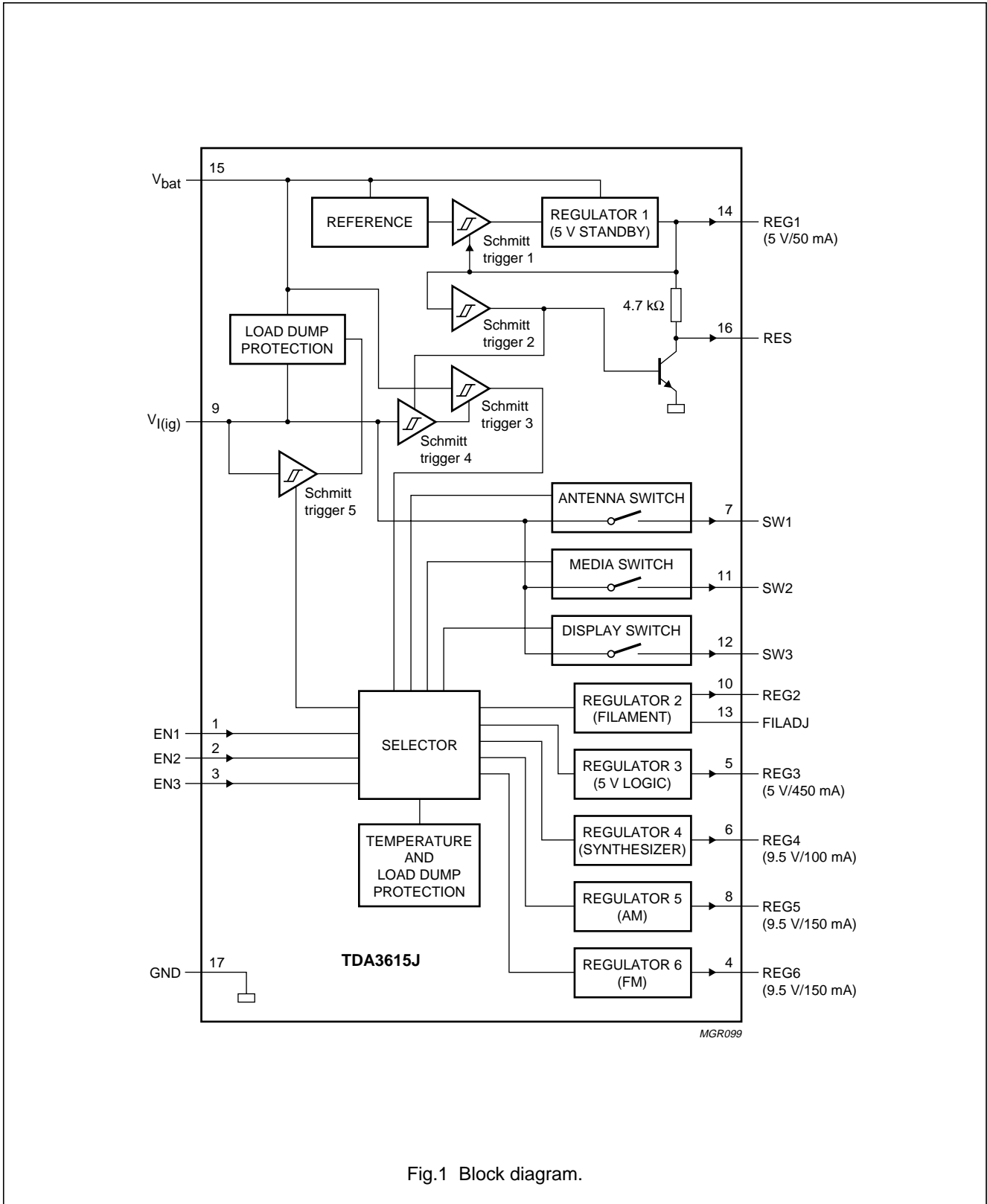

Fig.1 Block diagram.

Multiple voltage regulator

TDA3615J

PINNING

SYMBOL	PIN	DESCRIPTION
EN1	1	enable input 1
EN2	2	enable input 2
EN3	3	enable input 3
REG6	4	regulator 6 output, FM
REG3	5	regulator 3 output, 5 V logic
REG4	6	regulator 4 output, synthesizer
SW1	7	switch 1 output, antenna
REG5	8	regulator 5 output, AM
$V_{I(ig)}$	9	ignition input voltage
REG2	10	regulator 2 output, filament
SW2	11	switch 2 output, media
SW3	12	switch 3 output, display
FILADJ	13	filament adjustment
REG1	14	regulator 1 output, 5 V standby
V_{bat}	15	battery input voltage
RES	16	reset output
GND	17	ground

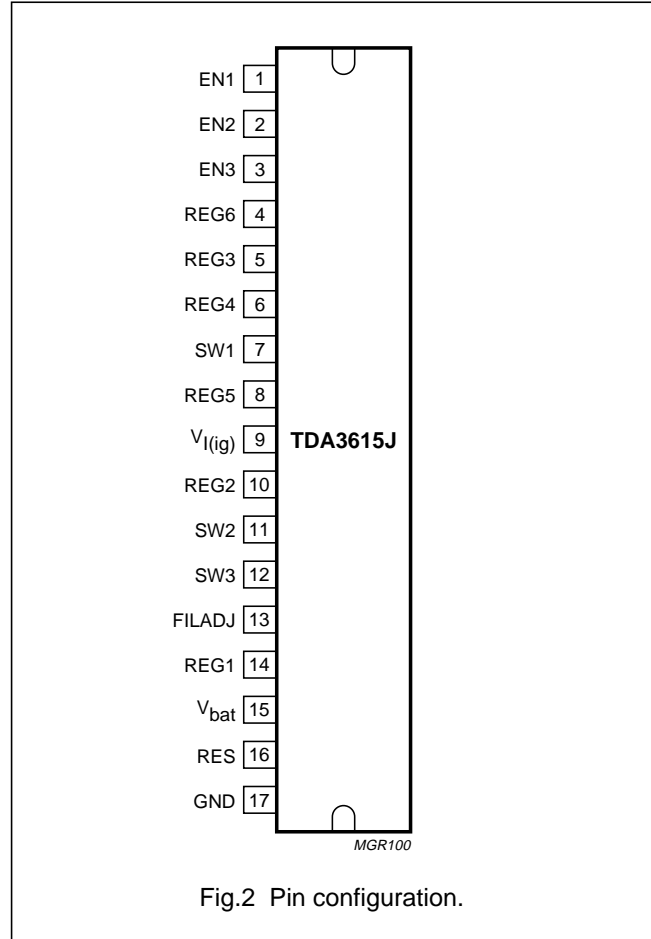

Fig.2 Pin configuration.

FUNCTIONAL DESCRIPTION

The TDA3615J is a multiple voltage regulator intended to supply a microprocessor (e.g. in car radio applications). Because of low-voltage operation of the application, a low-voltage drop regulator is used in the TDA3615J.

Regulator 1 (5 V standby) will switch on when the supply voltage exceeds 7.2 V for the first time and will switch off again when the output voltage of the regulator drops below 3.5 V.

Reset is used to indicate that the regulator output voltage is within its voltage range. This start-up feature is built-in to secure a smooth start-up of the microprocessor at first connection, without uncontrolled switching of the standby regulator during the start-up sequence.

All other regulators and switches can be switched on and off by using the three control input pins. This is only possible when both supply voltages (V_{bat} and $V_{I(ig)}$) are

within their voltage range. Table 1 shows all possible states.

The filament regulator output voltage of the TDA3615J can be adjusted with pin FILADJ.

All output pins are fully protected. The regulators are protected against load dump and short-circuit (foldback current protection, except the filament regulator output). At load dump all regulator outputs will go LOW except the 5 V standby regulator output.

The antenna switch and the media switch can withstand 'loss of ground'. This means that the ground pin is disconnected and the switch output is connected to ground (V_{bat} and $V_{I(ig)}$ are normally connected to the right pin).

Multiple voltage regulator

TDA3615J

Selector settings

Table 1 Possible states of outputs depending on inputs

STATE	INPUTS					OUTPUTS								
	V _{bat}	V _{I(ig)}	EN1	EN2	EN3	REG1	REG2	REG3	REG4	REG5	REG6	SW1	SW2	SW3
1	0	X ⁽¹⁾	X ⁽¹⁾	X ⁽¹⁾	X ⁽¹⁾	0	0	0	0	0	0	0	0	0
2	1	0	X ⁽¹⁾	X ⁽¹⁾	X ⁽¹⁾	1	0	0	0	0	0	0	0	0
3	1	1	0	0	0	1	0	0	0	0	0	0	0	0
4	1	1	0	0	1	1	1	1	1	0	1	1	0	1
5	1	1	0	1	0	1	1	1	1	1	0	1	0	1
6	1	1	0	1	1	1	1	1	0	0	0	0	1	1
7	1	1	1	0	0	1	1	1	0	0	0	0	0	1
8	1	1	1	0	1	1	1	1	1	0	1	1	1	1
9	1	1	1	1	0	1	1	1	1	1	0	1	1	1
10	1	1	1	1	1	1	1	1	1	0	0	1	1	1

Note

1. X = don't care.

LIMITING VALUES

In accordance with the Absolute Maximum Rating System (IEC 134).

SYMBOL	PARAMETER	CONDITIONS	MIN.	MAX.	UNIT
V _{bat/I(ig)}	supply voltage				
	operating	regulators on	–	18	V
	jump start	t ≤ 10 minutes	–	30	V
	load dump protection	t ≤ 50 ms; t _r ≥ 2.5 ms	–	50	V
V _{rp}	reverse polarity voltage	non-operating	–	–18	V
P _{tot}	total power dissipation	T _{amb} = 25 °C	–	62.5	W
T _{stg}	storage temperature	non-operating	–55	+150	°C
T _{amb}	ambient temperature	operating	–40	+85	°C
T _j	junction temperature	operating	–40	+150	°C

THERMAL CHARACTERISTICS

SYMBOL	PARAMETER	CONDITIONS	VALUE	UNIT
R _{th(j-c)}	thermal resistance from junction to case		2	K/W
R _{th(j-a)}	thermal resistance from junction to ambient	in free air	40	K/W

QUALITY SPECIFICATION

Quality specification is in accordance with "SNW-FQ-611E".

Multiple voltage regulator

TDA3615J

CHARACTERISTICS

$V_{\text{bat}} = V_{I(\text{ig})} = 14.4 \text{ V}$; $T_{\text{amb}} = 25 \text{ }^\circ\text{C}$; see Fig.4; unless otherwise specified.

SYMBOL	PARAMETER	CONDITIONS	MIN.	TYP.	MAX.	UNIT
Supply						
$V_{\text{bat}/I(\text{ig})}$	supply voltage					
	operating	regulators on	11	14.4	18	V
	jump start	$t \leq 10$ minutes	–	–	30	V
	load dump protection	$t \leq 50 \text{ ms}$; $t_r \geq 2.5 \text{ ms}$	–	–	50	V
I_q	quiescent supply current	$V_{\text{bat}} = 14.4 \text{ V}$; $V_{I(\text{ig})} < 1 \text{ V}$; note 1	–	110	250	μA
		$V_{\text{bat}} = V_{I(\text{ig})} = 14.4 \text{ V}$; selector inputs 0,0,0; note 1	–	125	–	μA
Reset buffer						
$I_{\text{sink(L)}}$	LOW-level sink current		2	15	–	mA
$R_{\text{pu(int)}}$	internal pull-up resistance		3.7	4.7	5.7	k Ω
Selector control inputs						
V_{IL}	LOW-level input voltage		–0.5	–	+0.8	V
V_{IH}	HIGH-level input voltage		2.0	–	–	V
I_{IH}	HIGH-level input current	$V_{\text{IH}} > 2 \text{ V}$	–	–	1.0	mA
I_{IL}	LOW-level input current	$V_{\text{IL}} < 0.8 \text{ V}$	–1.0	–	–	mA
Regulator 1 for 5 V standby ($I_{\text{REG1}} = 1 \text{ mA}$ unless otherwise specified)						
$V_{\text{O(REG1)}}$	output voltage	$0.5 \text{ mA} \leq I_{\text{REG1}} \leq 50 \text{ mA}$	4.75	5.0	5.25	V
		$6.5 \text{ V} \leq V_{\text{bat}} \leq 18 \text{ V}$; note 2	4.75	5.0	5.25	V
		$18 \text{ V} \leq V_{\text{bat}} \leq 50 \text{ V}$; load dump; $I_{\text{REG1}} = 30 \text{ mA}$	4.75	5.0	5.25	V
ΔV_{LN}	line voltage regulation	$7 \text{ V} \leq V_{\text{bat}} \leq 18 \text{ V}$	–	3	50	mV
ΔV_{L}	load voltage regulation	$0.5 \text{ mA} \leq I_{\text{REG1}} \leq 50 \text{ mA}$	–	–	60	mV
SVRR	supply voltage ripple rejection	$f_i = 120 \text{ Hz}$; $V_{i(\text{p-p})} = 2 \text{ V}$	60	72	–	dB
V_d	drop-out voltage	$V_{\text{bat}} = 5 \text{ V}$; note 3	–	0.27	1	V
I_l	current limit	$V_{\text{REG1}} > 4.5 \text{ V}$	60	170	–	mA
I_{sc}	short-circuit current	$R_L \leq 0.5 \Omega$; note 5	15	60	–	mA
Regulator 2 for filament ($I_{\text{REG2}} = 5 \text{ mA}$ unless otherwise specified)						
$V_{\text{O(REG2)}}$	output voltage	$0.5 \text{ mA} \leq I_{\text{REG2}} \leq 300 \text{ mA}$	2.7	2.85	3.0	V
		$7.5 \text{ V} \leq V_{\text{bat}} \leq 16.9 \text{ V}$	2.7	2.85	3.0	V
		adjust control	1.1	adjust	$V_{I(\text{ig})}$	V
ΔV_{LN}	line voltage regulation	$7.5 \text{ V} \leq V_{\text{bat}} \leq 16.9 \text{ V}$	–	–	50	mV
ΔV_{L}	load voltage regulation	$5 \text{ mA} \leq I_{\text{REG2}} \leq 300 \text{ mA}$	–	–	70	mV
SVRR	supply voltage ripple rejection	$f_i = 120 \text{ Hz}$; $V_{i(\text{p-p})} = 2 \text{ V}$	60	80	–	dB
I_{sc}	short-circuit current	$R_L \leq 0.5 \Omega$	0.35	0.66	–	A

Multiple voltage regulator

TDA3615J

SYMBOL	PARAMETER	CONDITIONS	MIN.	TYP.	MAX.	UNIT
Regulator 3 for 5 V logic ($I_{REG3} = 5$ mA unless otherwise specified)						
$V_{O(REG3)}$	output voltage	$0.5 \text{ mA} \leq I_{REG3} \leq 450 \text{ mA}$	4.75	5.0	5.25	V
		$7.5 \text{ V} \leq V_{bat} \leq 16.9 \text{ V}$	4.75	5.0	5.25	V
ΔV_{LN}	line voltage regulation	$7.5 \text{ V} \leq V_{bat} \leq 16.9 \text{ V}$	–	–	50	mV
ΔV_L	load voltage regulation	$5 \text{ mA} \leq I_{REG3} \leq 450 \text{ mA}$	–	–	60	mV
SVRR	supply voltage ripple rejection	$f_i = 120 \text{ Hz}; V_{i(p-p)} = 2 \text{ V}$	60	80	–	dB
I_l	current limit	$V_{REG3} > 3.5 \text{ V}$	0.5	0.85	–	A
I_{sc}	short-circuit current	$R_L \leq 0.5 \Omega$; note 5	20	125	–	mA
Regulator 4 for synthesizer ($I_{REG4} = 5$ mA unless otherwise specified)						
$V_{O(REG4)}$	output voltage	$0.5 \text{ mA} \leq I_{REG4} \leq 100 \text{ mA}$	9.0	9.5	10.0	V
		$10.75 \text{ V} \leq V_{bat} \leq 16.9 \text{ V}$	9.0	9.5	10.0	V
ΔV_{LN}	line voltage regulation	$10.75 \text{ V} \leq V_{bat} \leq 16.9 \text{ V}$	–	–	50	mV
ΔV_L	load voltage regulation	$5 \text{ mA} \leq I_{REG4} \leq 100 \text{ mA}$	–	–	70	mV
SVRR	supply voltage ripple rejection	$f_i = 120 \text{ Hz}; V_{i(p-p)} = 2 \text{ V}$	60	70	–	dB
V_d	drop-out voltage	$I_{REG4} = 0.1 \text{ A}; V_{bat} = 9 \text{ V}$; note 4	–	0.18	0.5	V
I_l	current limit	$V_{REG4} > 7 \text{ V}$	0.35	0.57	–	A
I_{sc}	short-circuit current	$R_L \leq 0.5 \Omega$; note 5	20	160	–	mA
Regulator 5 for AM ($I_{REG5} = 5$ mA unless otherwise specified)						
$V_{O(REG5)}$	output voltage	$0.5 \text{ mA} \leq I_{REG5} \leq 150 \text{ mA}$	9.0	9.5	10.0	V
		$10.75 \text{ V} \leq V_{bat} \leq 16.9 \text{ V}$	9.0	9.5	10.0	V
ΔV_{LN}	line voltage regulation	$10.75 \text{ V} \leq V_{bat} \leq 16.9 \text{ V}$	–	–	50	mV
ΔV_L	load voltage regulation	$5 \text{ mA} \leq I_{REG5} \leq 150 \text{ mA}$	–	–	70	mV
SVRR	supply voltage ripple rejection	$f_i = 120 \text{ Hz}; V_{i(p-p)} = 2 \text{ V}$	60	70	–	dB
V_d	drop-out voltage	$I_{REG5} = 0.15 \text{ A}; V_{bat} = 9 \text{ V}$; note 4	–	0.35	1	V
I_l	current limit	$V_{REG5} > 7 \text{ V}$	0.2	0.37	–	A
I_{sc}	short-circuit current	$R_L \leq 0.5 \Omega$; note 5	50	130	–	mA
Regulator 6 for FM ($I_{REG6} = 5$ mA unless otherwise specified)						
$V_{O(REG6)}$	output voltage	$0.5 \text{ mA} \leq I_{REG6} \leq 150 \text{ mA}$	9.0	9.5	10.0	V
		$10.75 \text{ V} \leq V_{bat} \leq 16.9 \text{ V}$	9.0	9.5	10.0	V
ΔV_{LN}	line voltage regulation	$10.75 \text{ V} \leq V_{bat} \leq 16.9 \text{ V}$	–	–	50	mV
ΔV_L	load voltage regulation	$5 \text{ mA} \leq I_{REG6} \leq 150 \text{ mA}$	–	–	70	mV
SVRR	supply voltage ripple rejection	$f_i = 120 \text{ Hz}; V_{i(p-p)} = 2 \text{ V}$	60	70	–	dB
V_d	drop-out voltage	$I_{REG6} = 0.15 \text{ A}; V_{bat} = 9 \text{ V}$; note 4	–	0.4	1	V
I_l	current limit	$V_{REG6} > 7 \text{ V}$	0.2	0.37	–	A
I_{sc}	short-circuit current	$R_L \leq 0.5 \Omega$; note 5	50	125	–	mA
Power switch 1 (antenna)						
V_{d1}	drop-out voltage	$I_{SW1} = 0.55 \text{ A}$; note 4	0.1	0.45	1.6	V
V_{clamp1}	clamping voltage		–	15.2	16	V
I_M	peak current	$t < 1 \text{ s}$	1.7	1.9	–	A

Multiple voltage regulator

TDA3615J

SYMBOL	PARAMETER	CONDITIONS	MIN.	TYP.	MAX.	UNIT
Power switch 2 (media)						
V_{d2}	drop-out voltage	$I_{SW2} = 1 \text{ A}$; note 4	–	0.5	1.0	V
V_{clamp2}	clamping voltage		–	15.0	16	V
Power switch 3 (display)						
V_{d3}	drop-out voltage	$I_{SW3} = 0.35 \text{ A}$; note 4	–	0.5	1.0	V
V_{clamp3}	clamping voltage		–	15.2	16	V
Schmitt trigger 1 for regulator						
V_{thr}	rising threshold voltage	selector inputs 0,0,0 (state 3 in Table 1); $I_{REG1} = 10 \text{ mA}$	6.2	7.2	7.8	V
V_{thf}	falling threshold voltage	selector inputs 0,0,0 (state 3 in Table 1); $I_{REG1} = 10 \text{ mA}$	3.2	3.5	3.7	V
V_{hys}	hysteresis voltage		–	3.7	–	V
Schmitt trigger 2 for reset; note 6						
V_{thr}	rising threshold voltage	$I_{REG1} = 10 \text{ mA}$	4.28	4.45	4.73	V
V_{thf}	falling threshold voltage	$I_{REG1} = 10 \text{ mA}$	4.2	4.35	4.5	V
V_{hys}	hysteresis voltage		–	0.1	–	V
Schmitt trigger 3 for battery sense						
V_{thr}	rising threshold voltage	$V_{I(ig)} = 14.4 \text{ V}$; $R_L = 1 \text{ k}\Omega$	6.8	7.35	7.9	V
V_{thf}	falling threshold voltage	$V_{I(ig)} = 14.4 \text{ V}$; $R_L = 1 \text{ k}\Omega$	5.5	5.95	6.4	V
V_{hys}	hysteresis voltage		–	1.4	–	V
Schmitt trigger 4 for ignition sense						
V_{thr}	rising threshold voltage	$V_{bat} = 14.4 \text{ V}$; $R_L = 100 \Omega$	7.2	7.6	8.0	V
V_{thf}	falling threshold voltage	$V_{bat} = 14.4 \text{ V}$; $R_L = 100 \Omega$	6.0	6.3	6.8	V
V_{hys}	hysteresis voltage		–	1.3	–	V
Schmitt trigger 5 for load dump						
V_{thr}	rising threshold voltage	selector inputs 1,0,1 (state 8 in Table 1); note 7	17.5	18.5	19.5	V
V_{thf}	falling threshold voltage	selector inputs 1,0,1 (state 8 in Table 1); note 7	17	$V_{thr} - 0.3$	$V_{thr} - 0.1$	V

Notes

1. The quiescent current is measured when $R_L = \infty$.
2. Only if V_{bat} has exceeded 7.2 V.
3. The drop-out voltage of regulator 1 is measured between V_{bat} and V_{REGx} .
4. The drop-out voltage of regulators 2 to 6 and power switches 1, 2 and 3 are measured between $V_{I(ig)}$ and V_{REGx} or between $V_{I(ig)}$ and V_{SWx} .
5. The foldback current protection limits the dissipation power at short-circuit.
6. The voltage of regulator 1 sinks as a result of a supply voltage drop.
7. Only when one of the control pins is HIGH.

Multiple voltage regulator

TDA3615J

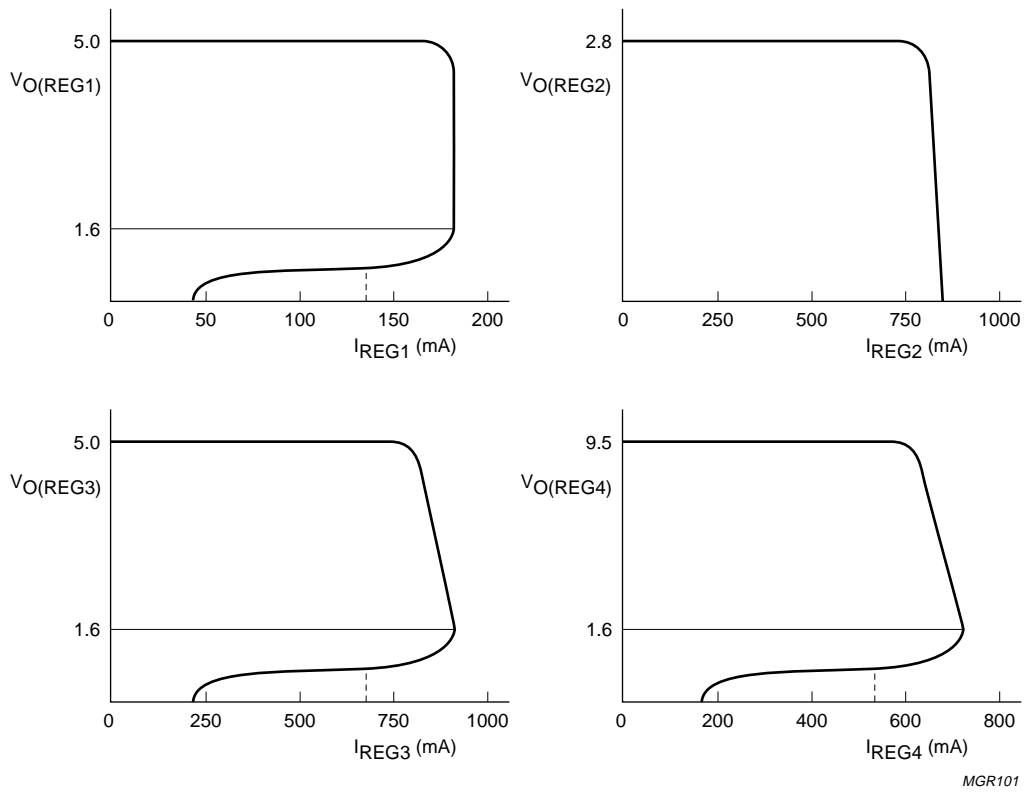

Fig.3 Typical foldback current protection behaviour.

Multiple voltage regulator

TDA3615J

TEST AND APPLICATION INFORMATION

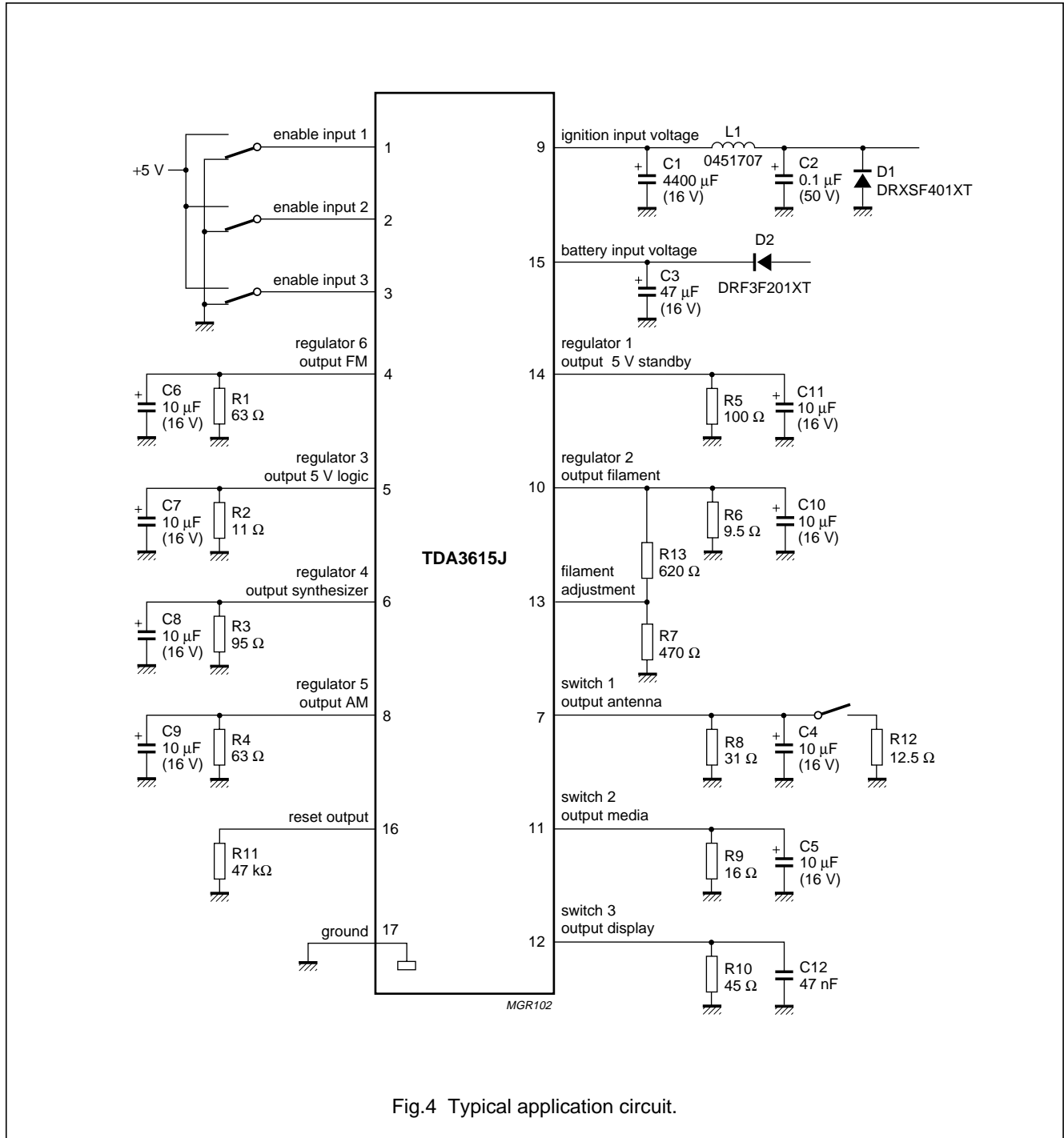

Fig.4 Typical application circuit.

Multiple voltage regulator

TDA3615J

Application information

NOISE

Table 2 Noise figures

REGULATOR	NOISE FIGURE (μV) ⁽¹⁾		
	$C_o = 10 \mu\text{F}$	$C_o = 47 \mu\text{F}$	$C_o = 100 \mu\text{F}$
1	175	145	100
2	125	98	85
3	180	150	125
4	290	260	190
5	290	260	190
6	290	260	190

Note

1. Measured at a bandwidth of 1 MHz.

The regulator outputs for regulators 2 to 6 are designed in such a way that the noise is very low and the stability is very good. The noise output voltages are depending on the output capacitors. Table 2 describes the influence of the output capacitors on the output noise.

STABILITY

The regulators are made stable with the external connected output capacitors.

With almost any output capacitor, stability can be guaranteed (see Figs 5, 6 and 7).

When only an electrolytic capacitor is used, the temperature behaviour of this output capacitor can cause oscillations at extreme low temperature. The next 2 examples show how an output capacitor value is selected. Oscillation problems can be avoided by adding a 47 nF capacitor in parallel with the electrolytic capacitor.

Example 1 (regulator 1)

Regulator 1 is made stable with an electrolytic output capacitor of 10 μF (ESR = 3.1 Ω). At -30°C the capacitor value is decreased to 3 μF and the ESR is increased to 22 Ω . The regulator will remain stable at -30°C (see Fig.5).

Example 2 (regulator 5)

Regulator 5 is made stable with a 2.2 μF electrolytic capacitor (ESR = 8 Ω). At -30°C the capacitor value is decreased to 0.8 μF and the ESR is increased to 56 Ω . Using Fig.6, the regulator will be instable at -30°C .

Even when only a small MKT capacitor of 47 nF is used as output capacitor, regulator 5 will remain stable over all temperatures.

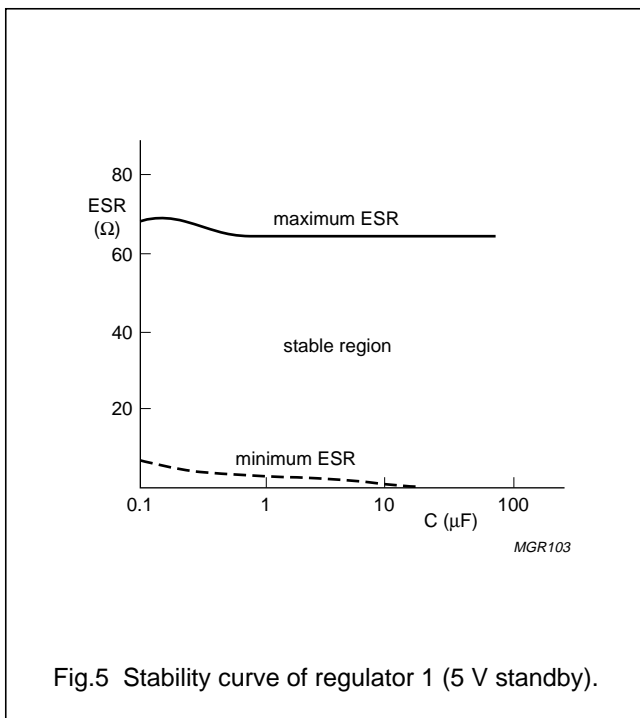

Fig.5 Stability curve of regulator 1 (5 V standby).

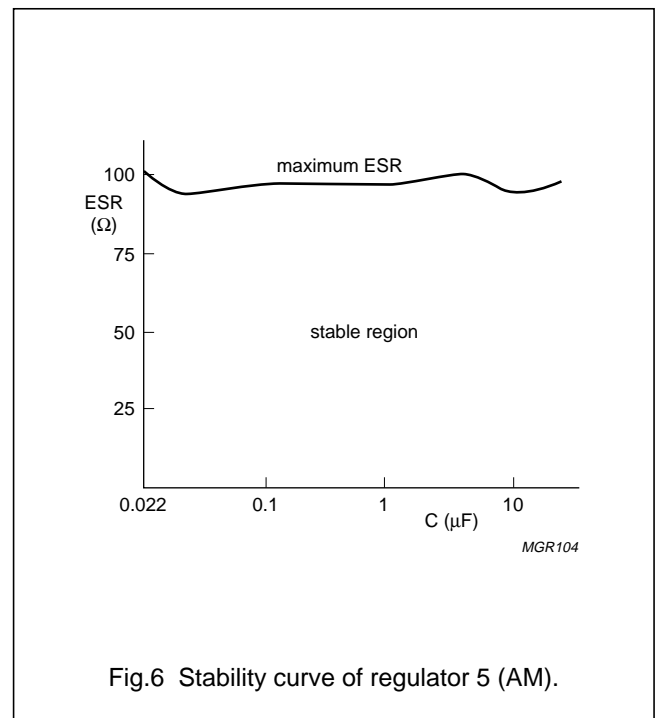
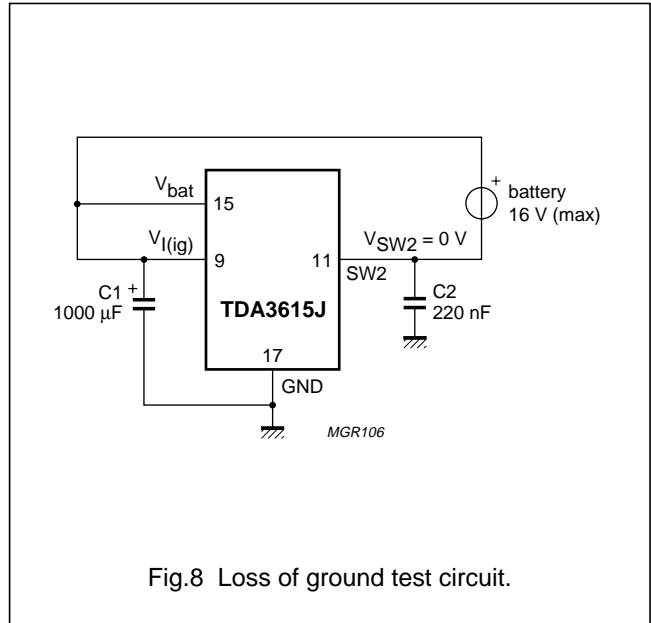
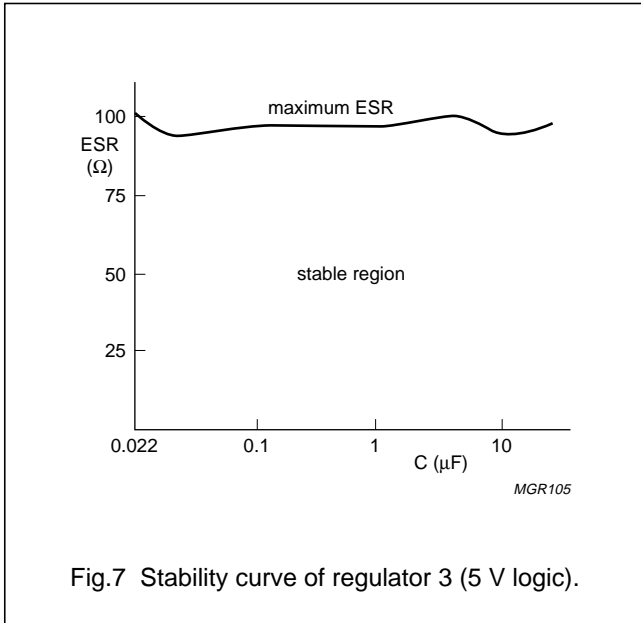

Fig.6 Stability curve of regulator 5 (AM).

Multiple voltage regulator

TDA3615J



LOSS OF GROUND PROTECTION

Two power switches (media and antenna) are protected for loss of ground. The loss of ground situation is depicted in Fig.8. The ground terminal of the battery is connected to the output of the media switch. Two problems occur:

1. At first connection a high charge current will flow through C1 to the ground terminal (pin 17) of the TDA3615J and out of the switch output (pin 11). The media and antenna switches are protected to limit this current.
1. When the switch is enabled, a short-circuit current will flow out of the power switch output (pin 11) because the output of the switch is shortened below substrate potential.

A special protection is built-in to avoid the media and antenna switches from being damaged during a loss of ground condition.

In practice, this condition can occur when the ground terminal of the total application is connected to the switch output due to a bad wiring.

CAPACITIVE LOADS ON POWER SWITCHES

Power switches can deliver a large current to the connected loads. When a supply voltage ripple is applied, large load currents will flow when capacitive loads are used in parallel with normal loads.

When the output of a power switch is forced above $V_{I(ig)}$ an internal protection is activated to switch off the switch as long as the fault is present.

The display switch in particular is sensitive to capacitive loads.

We therefore strongly advise:

- Use only a 47 nF output capacitor on the display switch
- Use a 10 μF capacitor on the outputs of the antenna and media switch.

On the outputs of regulators 2 to 6 a capacitor of 47 nF can be used; larger values are possible but not necessary to guarantee stability (see Figs 5, 6 and 7).

Multiple voltage regulator

TDA3615J

PACKAGE OUTLINE

DBS17P: plastic DIL-bent-SIL power package; 17 leads (lead length 12 mm)

SOT243-1

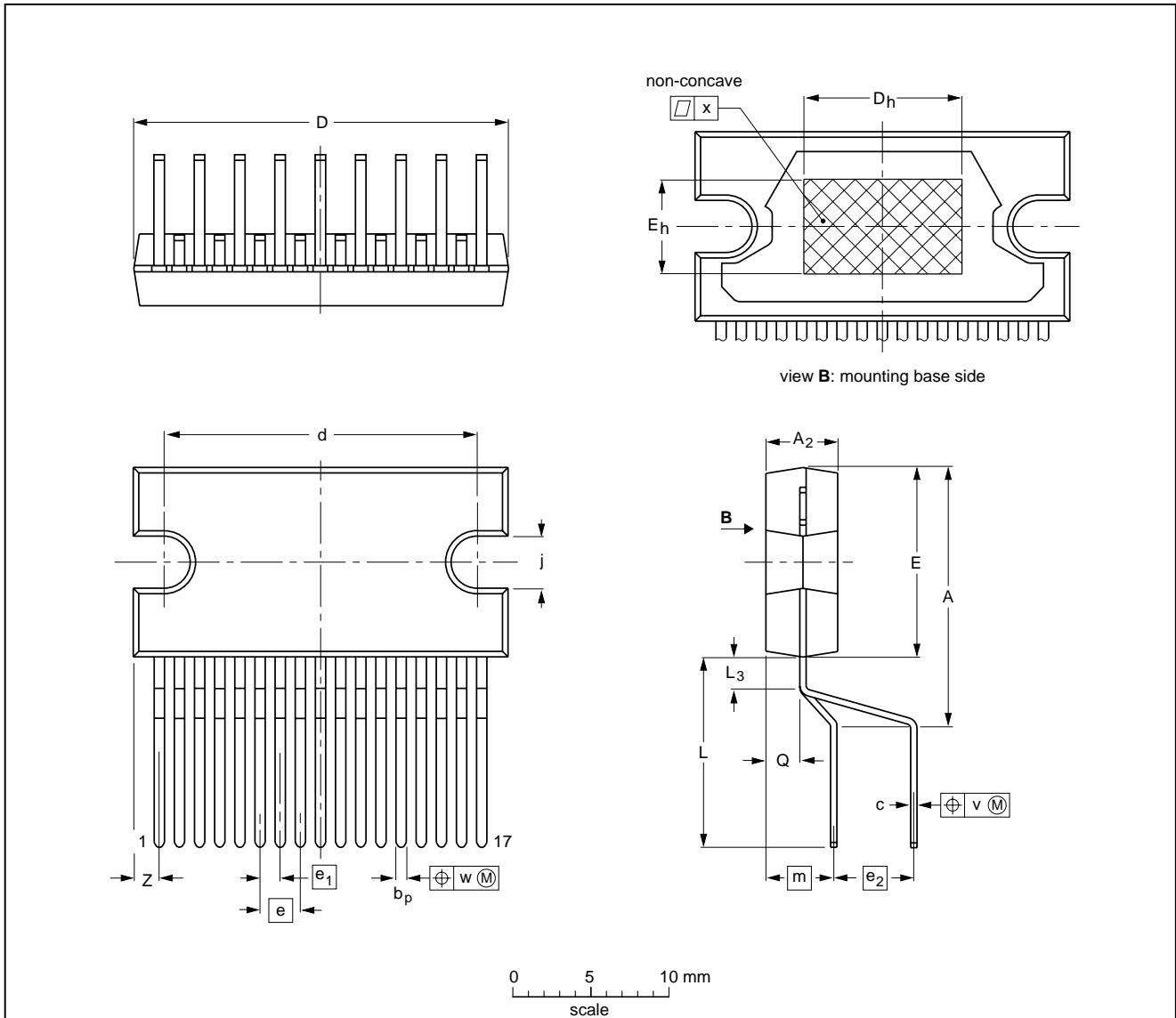

DIMENSIONS (mm are the original dimensions)

UNIT	A	A ₂	b _p	c	D ⁽¹⁾	d	D _h	E ⁽¹⁾	e	e ₁	e ₂	E _h	j	L	L ₃	m	Q	v	w	x	Z ⁽¹⁾
mm	17.0 15.5	4.6 4.2	0.75 0.60	0.48 0.38	24.0 23.6	20.0 19.6	10	12.2 11.8	2.54	1.27	5.08	6	3.4 3.1	12.4 11.0	2.4 1.6	4.3	2.1 1.8	0.8	0.4	0.03	2.00 1.45

Note

1. Plastic or metal protrusions of 0.25 mm maximum per side are not included.

OUTLINE VERSION	REFERENCES				EUROPEAN PROJECTION	ISSUE DATE
	IEC	JEDEC	EIAJ			
SOT243-1						95-03-11 97-12-16

Multiple voltage regulator

TDA3615J

SOLDERING

Introduction

There is no soldering method that is ideal for all IC packages. Wave soldering is often preferred when through-hole and surface mounted components are mixed on one printed-circuit board. However, wave soldering is not always suitable for surface mounted ICs, or for printed-circuits with high population densities. In these situations reflow soldering is often used.

This text gives a very brief insight to a complex technology. A more in-depth account of soldering ICs can be found in our "Data Handbook IC26; Integrated Circuit Packages" (order code 9398 652 90011).

Soldering by dipping or by wave

The maximum permissible temperature of the solder is 260 °C; solder at this temperature must not be in contact with the joint for more than 5 seconds. The total contact time of successive solder waves must not exceed 5 seconds.

The device may be mounted up to the seating plane, but the temperature of the plastic body must not exceed the specified maximum storage temperature ($T_{stg\ max}$). If the printed-circuit board has been pre-heated, forced cooling may be necessary immediately after soldering to keep the temperature within the permissible limit.

Repairing soldered joints

Apply a low voltage soldering iron (less than 24 V) to the lead(s) of the package, below the seating plane or not more than 2 mm above it. If the temperature of the soldering iron bit is less than 300 °C it may remain in contact for up to 10 seconds. If the bit temperature is between 300 and 400 °C, contact may be up to 5 seconds.

DEFINITIONS

Data sheet status	
Objective specification	This data sheet contains target or goal specifications for product development.
Preliminary specification	This data sheet contains preliminary data; supplementary data may be published later.
Product specification	This data sheet contains final product specifications.
Limiting values	
Limiting values given are in accordance with the Absolute Maximum Rating System (IEC 134). Stress above one or more of the limiting values may cause permanent damage to the device. These are stress ratings only and operation of the device at these or at any other conditions above those given in the Characteristics sections of the specification is not implied. Exposure to limiting values for extended periods may affect device reliability.	
Application information	
Where application information is given, it is advisory and does not form part of the specification.	

LIFE SUPPORT APPLICATIONS

These products are not designed for use in life support appliances, devices, or systems where malfunction of these products can reasonably be expected to result in personal injury. Philips customers using or selling these products for use in such applications do so at their own risk and agree to fully indemnify Philips for any damages resulting from such improper use or sale.

Philips Semiconductors – a worldwide company

Argentina: see South America

Australia: 34 Waterloo Road, NORTH RYDE, NSW 2113, Tel. +61 2 9805 4455, Fax. +61 2 9805 4466

Austria: Computerstr. 6, A-1101 WIEN, P.O. Box 213, Tel. +43 160 1010, Fax. +43 160 101 1210

Belarus: Hotel Minsk Business Center, Bld. 3, r. 1211, Volodarski Str. 6, 220050 MINSK, Tel. +375 172 200 733, Fax. +375 172 200 773

Belgium: see The Netherlands

Brazil: see South America

Bulgaria: Philips Bulgaria Ltd., Energoproject, 15th floor, 51 James Bourchier Blvd., 1407 SOFIA, Tel. +359 2 689 211, Fax. +359 2 689 102

Canada: PHILIPS SEMICONDUCTORS/COMPONENTS, Tel. +1 800 234 7381

China/Hong Kong: 501 Hong Kong Industrial Technology Centre, 72 Tat Chee Avenue, Kowloon Tong, HONG KONG, Tel. +852 2319 7888, Fax. +852 2319 7700

Colombia: see South America

Czech Republic: see Austria

Denmark: Prags Boulevard 80, PB 1919, DK-2300 COPENHAGEN S, Tel. +45 32 88 2636, Fax. +45 31 57 0044

Finland: Sinikalliontie 3, FIN-02630 ESPOO, Tel. +358 9 615800, Fax. +358 9 61580920

France: 51 Rue Carnot, BP317, 92156 SURESNES Cedex, Tel. +33 1 40 99 6161, Fax. +33 1 40 99 6427

Germany: Hammerbrookstraße 69, D-20097 HAMBURG, Tel. +49 40 23 53 60, Fax. +49 40 23 536 300

Greece: No. 15, 25th March Street, GR 17778 TAVROS/ATHENS, Tel. +30 1 4894 339/239, Fax. +30 1 4814 240

Hungary: see Austria

India: Philips INDIA Ltd, Band Box Building, 2nd floor, 254-D, Dr. Annie Besant Road, Worli, MUMBAI 400 025, Tel. +91 22 493 8541, Fax. +91 22 493 0966

Indonesia: PT Philips Development Corporation, Semiconductors Division, Gedung Philips, Jl. Buncit Raya Kav.99-100, JAKARTA 12510, Tel. +62 21 794 0040 ext. 2501, Fax. +62 21 794 0080

Ireland: Newstead, Clonskeagh, DUBLIN 14, Tel. +353 1 7640 000, Fax. +353 1 7640 200

Israel: RAPAC Electronics, 7 Kehilat Saloniki St, PO Box 18053, TEL AVIV 61180, Tel. +972 3 645 0444, Fax. +972 3 649 1007

Italy: PHILIPS SEMICONDUCTORS, Piazza IV Novembre 3, 20124 MILANO, Tel. +39 2 6752 2531, Fax. +39 2 6752 2557

Japan: Philips Bldg 13-37, Kohnan 2-chome, Minato-ku, TOKYO 108-8507, Tel. +81 3 3740 5130, Fax. +81 3 3740 5077

Korea: Philips House, 260-199 Itaewon-dong, Yongsan-ku, SEOUL, Tel. +82 2 709 1412, Fax. +82 2 709 1415

Malaysia: No. 76 Jalan Universiti, 46200 PETALING JAYA, SELANGOR, Tel. +60 3 750 5214, Fax. +60 3 757 4880

Mexico: 5900 Gateway East, Suite 200, EL PASO, TEXAS 79905, Tel. +9-5 800 234 7381

Middle East: see Italy

Netherlands: Postbus 90050, 5600 PB EINDHOVEN, Bldg. VB, Tel. +31 40 27 82785, Fax. +31 40 27 88399

New Zealand: 2 Wagener Place, C.P.O. Box 1041, AUCKLAND, Tel. +64 9 849 4160, Fax. +64 9 849 7811

Norway: Box 1, Manglerud 0612, OSLO, Tel. +47 22 74 8000, Fax. +47 22 74 8341

Pakistan: see Singapore

Philippines: Philips Semiconductors Philippines Inc., 106 Valero St. Salcedo Village, P.O. Box 2108 MCC, MAKATI, Metro MANILA, Tel. +63 2 816 6380, Fax. +63 2 817 3474

Poland: Ul. Lukiska 10, PL 04-123 WARSZAWA, Tel. +48 22 612 2831, Fax. +48 22 612 2327

Portugal: see Spain

Romania: see Italy

Russia: Philips Russia, Ul. Usatcheva 35A, 119048 MOSCOW, Tel. +7 095 755 6918, Fax. +7 095 755 6919

Singapore: Lorong 1, Toa Payoh, SINGAPORE 319762, Tel. +65 350 2538, Fax. +65 251 6500

Slovakia: see Austria

Slovenia: see Italy

South Africa: S.A. PHILIPS Pty Ltd., 195-215 Main Road Martindale, 2092 JOHANNESBURG, P.O. Box 7430 Johannesburg 2000, Tel. +27 11 470 5911, Fax. +27 11 470 5494

South America: Al. Vicente Pinzon, 173, 6th floor, 04547-130 SÃO PAULO, SP, Brazil, Tel. +55 11 821 2333, Fax. +55 11 821 2382

Spain: Balmes 22, 08007 BARCELONA, Tel. +34 93 301 6312, Fax. +34 93 301 4107

Sweden: Kottbygatan 7, Akalla, S-16485 STOCKHOLM, Tel. +46 8 5985 2000, Fax. +46 8 5985 2745

Switzerland: Allmendstrasse 140, CH-8027 ZÜRICH, Tel. +41 1 488 2741 Fax. +41 1 488 3263

Taiwan: Philips Semiconductors, 6F, No. 96, Chien Kuo N. Rd., Sec. 1, TAIPEI, Taiwan Tel. +886 2 2134 2865, Fax. +886 2 2134 2874

Thailand: PHILIPS ELECTRONICS (THAILAND) Ltd., 209/2 Sanpavuth-Bangna Road Prakanong, BANGKOK 10260, Tel. +66 2 745 4090, Fax. +66 2 398 0793

Turkey: Talatpasa Cad. No. 5, 80640 GÜLTEPE/ISTANBUL, Tel. +90 212 279 2770, Fax. +90 212 282 6707

Ukraine: PHILIPS UKRAINE, 4 Patrice Lumumba str., Building B, Floor 7, 252042 KIEV, Tel. +380 44 264 2776, Fax. +380 44 268 0461

United Kingdom: Philips Semiconductors Ltd., 276 Bath Road, Hayes, MIDDLESEX UB3 5BX, Tel. +44 181 730 5000, Fax. +44 181 754 8421

United States: 811 East Arques Avenue, SUNNYVALE, CA 94088-3409, Tel. +1 800 234 7381

Uruguay: see South America

Vietnam: see Singapore

Yugoslavia: PHILIPS, Trg N. Pasica 5/v, 11000 BEOGRAD, Tel. +381 11 625 344, Fax. +381 11 635 777

For all other countries apply to: Philips Semiconductors, International Marketing & Sales Communications, Building BE-p, P.O. Box 218, 5600 MD EINDHOVEN, The Netherlands, Fax. +31 40 27 24825

Internet: <http://www.semiconductors.philips.com>

© Philips Electronics N.V. 1998

SCA60

All rights are reserved. Reproduction in whole or in part is prohibited without the prior written consent of the copyright owner.

The information presented in this document does not form part of any quotation or contract, is believed to be accurate and reliable and may be changed without notice. No liability will be accepted by the publisher for any consequence of its use. Publication thereof does not convey nor imply any license under patent- or other industrial or intellectual property rights.

Printed in The Netherlands

545102/1200/01/pp16

Date of release: 1998 Jun 23

Document order number: 9397 750 03721

Let's make things better.

**Philips
Semiconductors**



PHILIPS