

DATA SHEET

TDA3868T

Quasi-split sound processor for all standards

Preliminary specification
File under Integrated Circuits, IC02

January 1992

Quasi-split sound processor for all standards

TDA3868T

FEATURES

- Quasi-split sound processor for all standards e. g. B/G (FM sound) and L (AM sound)
- Reduction of spurious video signals by tracking function and AFC for the vision carrier reference circuit; (indispensable for NICAM)
- AF2 signal automatically muted (at B/G) by input signal level
- AM signal processing for L standard and audio switching over
- Stereo-matrix correction
- AM output level typically 500 mV at $m = 0.54$ (+2.5 dB in comparison to TDA3858)

GENERAL DESCRIPTION

Separate symmetrical IF inputs for FM and AM sound.

Gain controlled wideband IF amplifier and input select switch.

AGC generation due to peak-sync for FM or mean signal level for AM.

Reference amplifier to regenerate the vision carrier.

Limiting amplifier optimized for AM suppression of the regenerated vision carrier signal and 90° phase shifter.

Intercarrier mixer for FM sound, output with low-pass filter.

Separate signal processing for 5.5 and 5.74 MHz intercarriers.

Wide supply voltage range, only 300 mW power dissipation at 5 V.

QUICK REFERENCE DATA

SYMBOL	PARAMETER	MIN.	TYP.	MAX.	UNIT
V_P	supply voltage (pin 24)	4.5	5	8.8	V
Data at $V_P = 5$ V					
I_P	supply current (pin 24)	–	60	72	mA
V_{iIF}	IF input sensitivity (–3 dB)	–	70	100	μ V
V_o	audio output signal for FM standard B/G (RMS value)	–	1	–	V
	audio output signal for AM standard L (RMS value)	–	0.5	–	V
THD	total harmonic distortion for FM	–	0.5	–	%
	for AM	–	1	–	%
S/N (W)	weighted signal-to-noise ratio for FM	–	68	–	dB
	for FM with 6 kHz sinus vision modulation	–	56	–	dB
	for AM	–	56	–	dB

ORDERING AND PACKAGE INFORMATION

EXTENDED TYPE NUMBER	PACKAGE			
	PINS	PIN POSITION	MATERIAL	CODE
TDA3868T	28	mini-pack	plastic	SOT136A ⁽¹⁾

Note

1. SOT136-1; 1996 November 25.

Quasi-split sound processor for all standards

TDA3868T

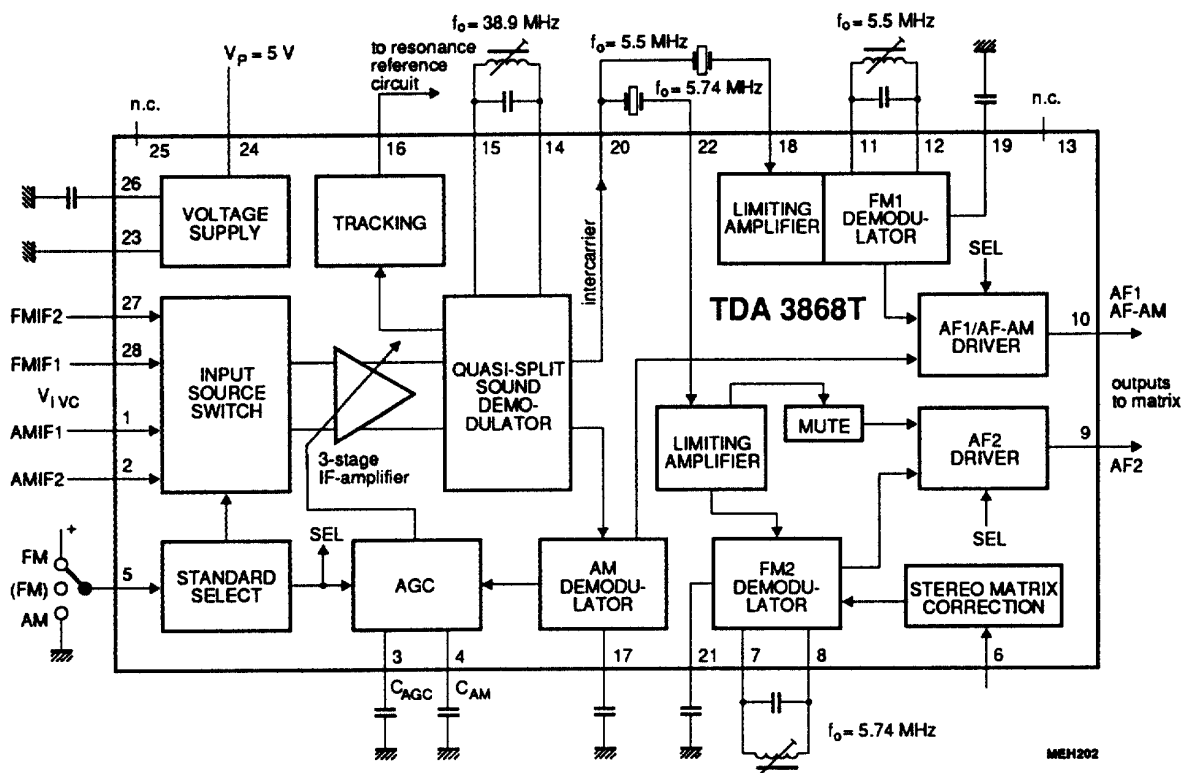

Fig.1 Block diagram (B/G and L standards).

Quasi-split sound processor for all standards

TDA3868T

PINNING

SYMBOL	PIN	DESCRIPTION
AMIF1	1	AM IF difference input 1 for L standard (32.4 MHz)
AMIF2	2	AM IF difference input 2 for L standard (32.4 MHz)
C _{AGC}	3	charge capacitor for AGC (FM and AM)
C _{AM}	4	charge capacitor for AM AGC
MODE	5	3-state input for standard select
MATR	6	input for stereo matrix correction
FM2R1	7	reference circuit for FM2 (5.74 MHz)
FM2R2	8	reference circuit for FM2 (5.74 MHz)
AF2	9	AF2 output (AF out of 5.74 MHz)
AF1	10	AF1 output (AF out of 5.5 MHz or AM)
FM1R1	11	reference circuit for FM1 (5.5 MHz)
FM1R2	12	reference circuit for FM1 (5.5 MHz)
n.c.	13	not connected
VC-R1	14	reference circuit for the vision carrier (38.9 MHz)
VC-R2	15	reference circuit for the vision carrier (38.9 MHz)
TRACK	16	DC output level for tracking
C _{AFAM}	17	DC-decoupling capacitor for AM demodulator (AF AM)
FM1I	18	intercarrier input for FM1 (5.5 MHz)
C _{AF1}	19	DC-decoupling capacitor for FM1 demodulator (AF1)
ICO	20	intercarrier output signal (5.5/5.74 MHz)
C _{AF2}	21	DC-decoupling capacitor for FM2 demodulator (AF2)
FM2I	22	intercarrier input for FM2 (5.74 MHz)
GND	23	ground (0 V)
V _P	24	+5 to +8 V supply voltage
n.c.	25	not connected
C _{ref}	26	charge capacitor for reference voltage
FMIF1	27	IF difference input 1 (B/G standard, 38.9 MHz)
FMIF2	28	IF difference input 2 (B/G standard, 38.9 MHz)

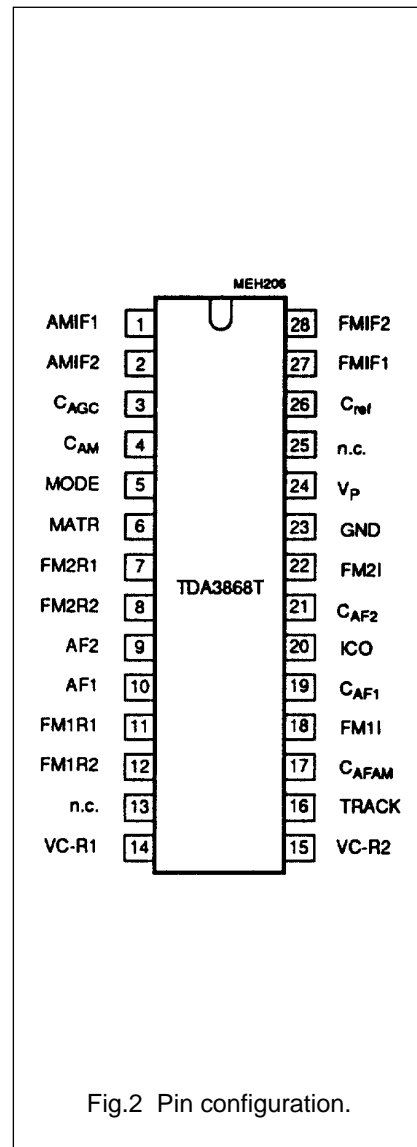

Fig.2 Pin configuration.

Quasi-split sound processor for all standards

TDA3868T

FUNCTIONAL DESCRIPTION

The quasi-split sound processor is for all standards. Dependent on the voltage on pin 5 either FM mode (B/G) or AM mode (L) is selected.

B/G standard (FM mode): Pins 27 and 28 are active, AGC detector uses peak sync level. Sound carrier SC1 (5.5 MHz) provides AF1, sound carrier SC2 (5.74 MHz) provides AF2. With no sound carrier SC2 on pin 22, AF2 output is muted (in mid-position of the standard select switch FM mode without muting of AF2 is selected). The mute circuit prevents false signal recognition in the stereo decoder at high IF signal levels when no second sound carrier exists (mono) and an AF signal is present in the identification signal frequency range.

With 1 mV on pin 22, under measurement conditions, AF2 is switched on (see limiting amplifier). Weak input signals on pins 27 and 28 generate noise on pin 22, which is present in the intercarrier signal and passes through the 5.74 MHz filter. Noise on pin 22 inhibits muting. No misinterpretation due to white noise occurs in the stereo decoder; when non-correlated noise masks the identification signal frequencies, which may be present in sustained tone signals. The stereo decoder remains switched to mono.

The series capacitor C_S in 38.9 MHz resonant circuit provides a notch at the sound carrier frequency in order to provide more attenuation for the sound carrier in the vision carrier reference channel. The ratio of parallel/series capacitor depends on the ratio of VC/SC frequency and has to be adapted to other TV transmission standards if necessary, according

$$\text{to } C_S = C_P (f_{VC}/f_{SC})^2 - \dot{C}_P.$$

The result is an improved "intercarrier buzz" (up to 10 dB improvement in sound channel 2 with 250 kHz video modulation for B/G stereo) or suppression of 350 kHz video modulated beat frequency in the digitally-modulated NICAM subcarrier. The picture carrier for quadrature demodulation in the intercarrier mixer is not exactly 90 degrees due to the shift variation in the integrated phase shift network. The tuning of the LC reference circuit to provide optimal video suppression at the intercarrier output is not the same as that to provide optimal intercarrier buzz suppression. In order to optimize the AF signal performance, a fine tuning for the optimal S/N at the sound channel 2 (from 5.74 MHz) may be performed with a 250 kHz square wave video modulation.

Measurements at the demodulators: For all signal-to-noise measurements the generator must meet the following specifications;

phase modulation errors < 0.5 degree for B/W-jumps intercarrier signal-to-noise ratio as measured with "TV-demodulator AMF2" (weighted S/N) must be > 60 dB at 6 kHz sine wave modulation of the B/W-signal.

Signal-to-noise ratios are measured with $\Delta f = \pm 50$ kHz deviation and $f_m = 1$ kHz; with a deviation of ± 27 kHz the S/N ratio is deteriorated by 5.3 dB.

L standard (AM mode): Pins 1 and 2 are active, AGC detector uses mean signal level. The audio signal from the AM demodulator is output on AF1 with AF2 output muted.

Quasi-split sound processor for all standards

TDA3868T

LIMITING VALUES

In accordance with the Absolute Maximum System (IEC 134).

SYMBOL	PARAMETER	MIN.	MAX.	UNIT
V_P	supply voltages (pin 24)	–	8.8	V
V_I	voltage (pins 1, 2, 5, 9, 10, 18, 20, 22, 27 and 28)	0	V_P	V
P_{tot}	total power dissipation	0	635	mW
T_{stg}	storage temperature range	–25	150	°C
T_{amb}	operating ambient temperature range	0	70	°C
V_{ESD}	electrostatic handling ⁽¹⁾			
	all pins except 1, 2, 27 and 28	±500	–	V
	pins 1, 2, 27 and 28	+400	–	V
	pins 1, 2, 27 and 28	–500	–	V

Note

1. Equivalent to discharging a 200 pF capacitor through a 0 Ω series resistor.

Quasi-split sound processor for all standards

TDA3868T

CHARACTERISTICS

$V_P = 5\text{ V}$ and $T_{amb} = 25\text{ °C}$, measurements taken in Fig.3 with $f_{VC} = 38.9\text{ MHz}$, $f_{SC1} = 33.4\text{ MHz}$ and $f_{SC2} = 33.158\text{ MHz}$. Vision carrier (VC) modulated with different video signals, modulation depth 100 % (proportional to 10 % residual carrier).

Vision carrier amplitude (RMS value) $V_{iVC} = 10\text{ mV}$; vision to sound carrier ratios are VC/SC1 = 13 dB and VC/SC2 = 20 dB. Sound carriers (SC1, SC2) modulated with $f = 1\text{ kHz}$ and deviation $\Delta f = \pm 50\text{ kHz}$ unless otherwise specified.

SYMBOL	PARAMETER	CONDITIONS	MIN.	TYP.	MAX.	UNIT
V_P	supply voltage.range (pin 24)		4.5	5	8.8	V
I_P	supply current (pin 24)	$V_P = 5\text{ V}$	48	60	72	mA
IF input not activated (pins 1-2 or 27-28)						
R_I	input resistance		–	–	100	Ω
V_I	DC input voltage (pins 1-2 or 31-32)	LOW internal set	–	–	0.1	V
$\alpha_{1,2-27,28}$	crosstalk attenuation of IF input switch	note 1	50	56	–	dB
IF source control (pin 5)						
V_5	input voltage in order to obtain standards B/G (FM) with automatic muting	pin 5 connected	2.8	–	V_{P1}	V
		pin 5 open-circuit	–	2.8	–	V
	B/G (FM) without muting	pin 5 connected or alternative measure: 22 k Ω to GND	1.3	–	2.3	V
	L (AM sound)	pin 5 connected	0	–	0.8	V
I_5	input current	$V_5 = V_P$	–	–	100	μA
		$V_5 = 0$	–	–	–300	μA
IF amplifier (pins 27-28 or 1-2)						
R_I	input resistance		2.75	2.2	2.65	k Ω
C_I	input capacitance		1.0	1.5	2.2	pF
V_I	DC potential, voltage (pins 1, 2, 27, 28)		–	1.75	–	V
V_i IF	maximum input signal (RMS value)	$V_o = +1\text{ dB}$	70	100	–	mV
	input signal sensitivity B/G standard (RMS value, pins 27-28)	–3 dB intercarrier signal reduction on pin 20	–	70	100	μV
	input signal sensitivity L standard (RMS value, pins 1-2)	–3 dB intercarrier signal reduction on pin 10	–	70	100	μV
ΔG_V	IF gain control range		60	63	–	dB
B	IF bandwidth	–3 dB	50	70	–	MHz
V_3	voltage range for gain control (pin 3)	$G_{min}-G_{max}$	1.7	–	2.6	V
Resonance amplifier (pins 14-15)						
V_o	vision carrier amplitude (peak-to-peak value)	$f_o = 38.9\text{ MHz}$	–	270	–	mV
R_{14-15}	operating resistance		–	4	–	k Ω
L	inductance	Fig.3 and 5	–	0.247	–	μH
C	capacitance	$C_S = 27\text{ pF}$	–	68	–	pF

Quasi-split sound processor for all standards

TDA3868T

SYMBOL	PARAMETER	CONDITIONS	MIN.	TYP.	MAX.	UNIT
Q_L	Q-factor of resonant circuit	$Q_o = 90$	–	40	–	
$V_{14, 15}$	DC voltage (pins 14 and 15)		–	V_{p-1}	–	V
Intercarrier mixer output (pin 20)						
V_o	output signal for 5.5 MHz (RMS value)		71	95	125	mV
	output signal for 5.74 MHz (RMS value)		32	43	56	mV
B	IF bandwidth	–1 dB	–	8.5	–	MHz
		–3 dB	–	10	–	MHz
V_{VID}/V_{20}	residual video AM on intercarrier	note 2	–	3	10	%
V_{VC}	residual vision carrier (RMS value)	1st/2nd harmonic; (38.9/77.8 MHz)	–	0.5	1	mV
R_{20}	output resistance (emitter follower)	1 mA emitter current	–	30	–	Ω
I_o	allowable AC output current (pin 20)		–	–	± 0.7	mA
I_{20}	allowable DC output current		–	–	–2	mA
V_{20}	DC voltage		–	1.75	–	V
Limiting amplifiers (pins 18 and 22)						
V_i	minimum input signal (RMS value)	–3 dB AF signal	–	300	450	μ V
	maximum input signal (RMS value)		200	–	–	mV
$R_{18, 22}$	input resistance		–	560	–	Ω
$V_{18, 22}$	DC voltage		–	0	–	V
V_i	level detector threshold for no muting (RMS value, pin 22)	only 5.74 MHz channel	–	1	–	mV
ΔV_i	hysteresis of level detector		–	5	–	dB
Tracking automatic frequency control (AFC) of the vision carrier reference circuit.						
V_o	tracking output voltage range (pin 16)	note 3	$V_{P1-3.3}$	–	V_{P1-1}	V
F_{TR}	tracking reducing factor for black picture		–	9	–	
	white test picture		–	4	–	
	50 % grey picture		–	6	–	
S	AFC steepness (open loop) for black picture		–	–8	–	mV/kHz
	white test picture		–	–3	–	mV/kHz
	50 % grey picture		–	–5.5	–	mV/kHz

Quasi-split sound processor for all standards

TDA3868T

SYMBOL	PARAMETER	CONDITIONS	MIN.	TYP.	MAX.	UNIT
FM1 and FM2 demodulators						
Measurements with FM IF input signals of 5.5 MHz and 5.74 MHz with $V_{i\text{IF}}(\text{rms}) = 10\text{ mV}$ ($f_{\text{mod}} = 1\text{ kHz}$, deviation $\Delta f = \pm 50\text{ kHz}$) at pins 18 and 22 without ceramic filters, $R_S = 50\ \Omega$. De-emphasis $50\ \mu\text{s}$ and $V_S = V_P$ (B/G standard). Q_L -factor = 11 for resonant circuits at pins 7-8 and 11-12.						
V_{IC}	intercarrier signals (RMS values, pins 7-8 and 11-12)		–	100	–	mV
V_{DC}	DC voltage (pins 7, 8, 11 and 12)		–	1.8	–	V
V_o	AF output signals (RMS values, pins 9 and 10)		0.75	0.95	1.20	V
ΔV_o	difference of AF signals between channels (pins 9 and 10)	pin 6 open-circuit; note 4	–	–	1	dB
$R_{9,10}$	output resistance		–	100	–	Ω
$V_{9,10}$	DC voltage		–	2.1	–	V
$I_{9,10}$	allowed AC current of emitter output (peak value)	note 5	–	–	± 1.5	mA
$I_{9,10}$	maximum allowed DC output current		–	–	–2	mA
THD	total harmonic distortion		–	0.5	1.0	%
V_o	AF output signal (RMS value)	THD = 1.5 %	1.25	–	–	V
α_{AM}	AM suppression	1 kHz, $m = 0.3$	48	54	–	dB
S/N(W)	weighted signal-to-noise ratio	CCIR 468-3	64	68	–	dB
B	AF bandwidth	–3 dB	0.02	–	100	kHz
α_{CR}	crosstalk attenuation (pins 9-10)		60	70	–	dB
V_6	adjusting voltage for AF2 signal (pin 6)	note 6	0	–	5	V
ΔG_{AF2}	minimum gain range	due to V_6	–1.5	–	1.0	dB
	typical gain range	due to V_6	–2.5	–	1.5	dB
$V_{19,21}$	DC voltage (pins 19 and 21)		–	1.7	–	V
AM mode , input signal at pins 1-2		SC = 32.4 MHz; $f_{\text{mod}} = 1\text{ kHz}$, $m = 0.54$; $V_{i\text{AM}} = 10\text{ mV rms}$				
V_o	AF output signal on pin 10 (RMS value)		400	500	600	mV
R_{10}	output resistance (pin 10)		–	100	–	Ω
I_o	maximum AC output current (peak value)	note 5	–	–	± 1.5	mA
I_{10}	maximum DC output current		–	–	–2	mA
V_{10}	DC voltage		–	2.1	–	V
THD	total harmonic distortion	Fig.4	–	1	2	%
S/N(W)	weighted signal-to-noise ratio	CCIR 468-3	50	56	–	dB
B	AF bandwidth	–3 dB	0.02	–	100	kHz
V_{17}	DC voltage (pin 17)		–	2	–	V

Quasi-split sound processor for all standards

TDA3868T

SYMBOL	PARAMETER	CONDITIONS	MIN.	TYP.	MAX.	UNIT
Audio frequency performance for FM operation in B/G standard ($V_5 = V_P$) unless otherwise specified.						
Measurements on AF outputs (pins 9 and 10)						
V_o	signal attenuation of AF signal switches					
	mute: AF2 on pin 9	$V_5 = 0$	70	–	–	dB
	AM mode: not required signal AF1 on pin 10 (from FM)	5.5 MHz on pin 18; $V_5 = 0$; $V_i = 10$ mV	70	–	–	dB
	FM mode: not required signal AF1 on pin 10 (from AM)	signal for L standard (pins 1-2); $V_5 = V_P$	70	–	–	dB
$dV_{9,10}$	DC level deviation (pins 9 and 10)	when switching to FM or AM sound or Mute	–	5	25	mV
S/N(W)	weighted signal-to-noise ratio on output pin 10	CCIR 468-3 de-emphasis 50 μ s				
	black picture	$f_i = 5.5$ MHz	59	63	–	dB
	2T/20T pulses with white bar	$f_i = 5.5$ MHz	57	61	–	dB
	6 kHz sine wave, B/W-modulated	$f_i = 5.5$ MHz	52	56	–	dB
	250 kHz square wave B/W-modulated	$f_i = 5.5$ MHz	50	56	–	dB
	on output pin 9					
	black picture	$f_i = 5.742$ MHz	57	61	–	dB
	2T/20T pulses with white bar	$f_i = 5.742$ MHz	55	59	–	dB
	6 kHz sine wave, B/W-modulated	$f_i = 5.742$ MHz	50	54	–	dB
	250 kHz square wave B/W-modulated	$f_i = 5.742$ MHz	50	56	–	dB
RR	ripple rejection	all standards; $f_R = 70$ Hz; $V_R = 200$ mV (p-p)	30	40	–	dB

Notes

- Crosstalk attenuation of IF input switch, measured at $R_{14-15} = 470 \Omega$ (instead of LC circuit); input signal $V_i = 20$ mV rms (pins 27–28). AGC voltage V_3 set to a value to achieve $V_o = 20$ mV rms (pins 14–15). After switching ($V_5 = 0$ V) measure attenuation. IF coupling with OFWG3203 and OFWL9350 (Siemens).
- Spurious intercarrier AM: $m = (A-B)/A$ (wherein A = signal at sync; B = signal with 100 % picture modulation.)
- Automatic frequency control (AFC) of the vision carrier reference circuit (pins 14 and 15) for reducing spurious video signals in the stereo/dual sound modes. The factor of reducing F_{TR} at a deviation Δf_{VC} specifies the ratio of spurious signals with/without tracking function.
- AF2 signal can be adjusted by V_6
- For larger current: $R_L > 2.2$ k Ω (pin 9 or 10 to GND) in order to increase the bias current of the output emitter follower.
- If not used, pin 6 should not be connected.

Quasi-split sound processor for all standards

TDA3868T

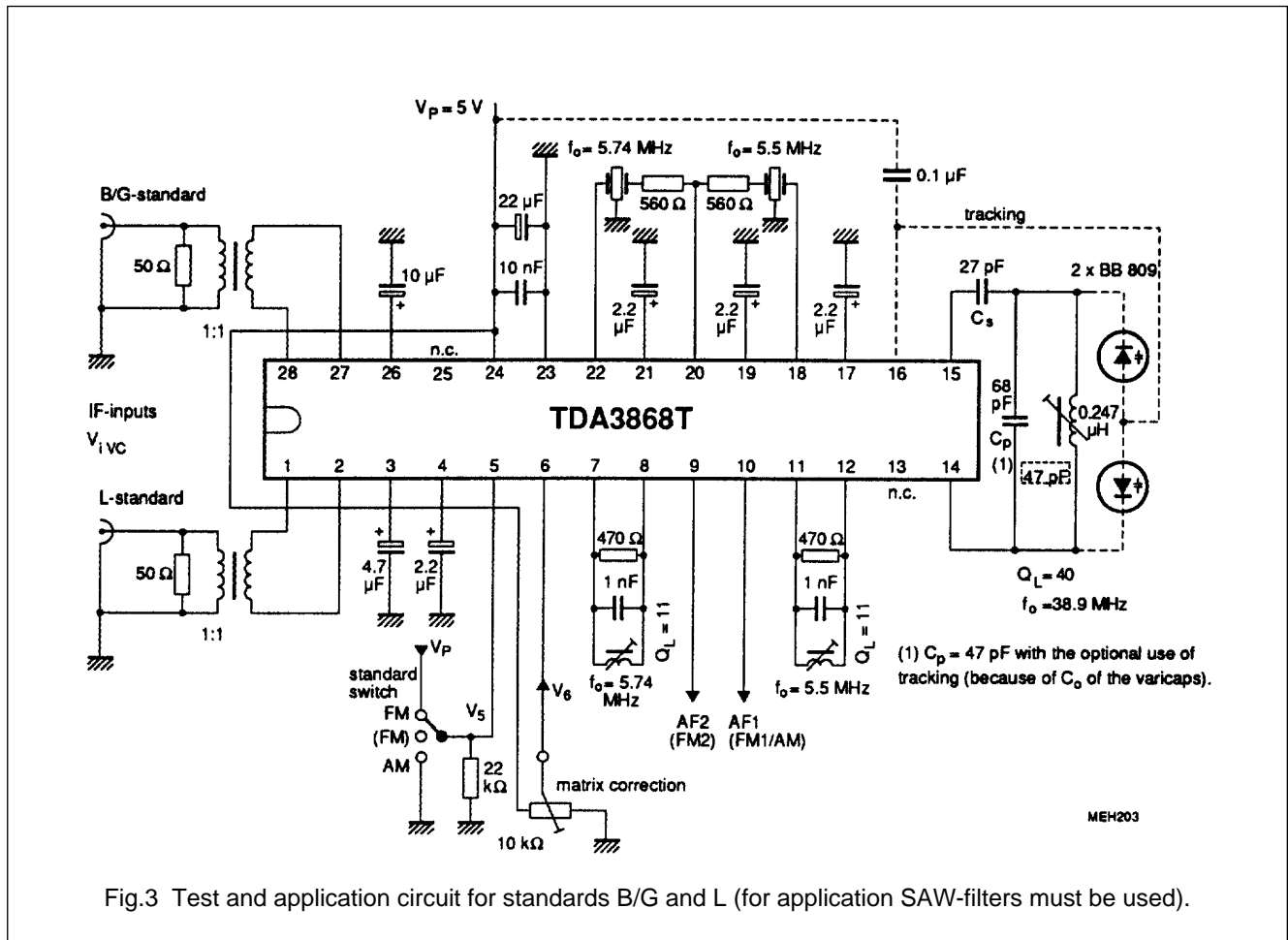

Fig.3 Test and application circuit for standards B/G and L (for application SAW-filters must be used).

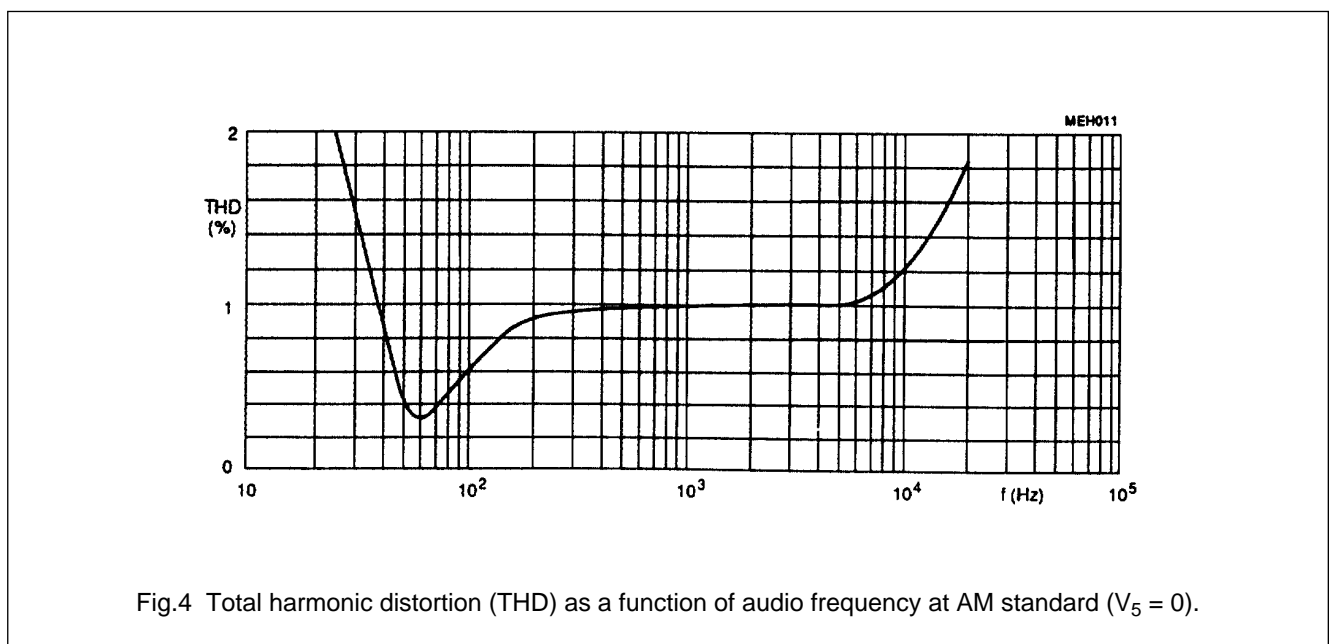
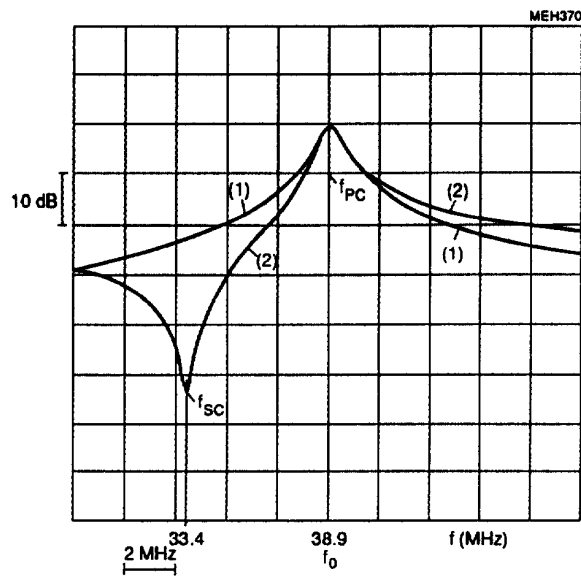

Fig.4 Total harmonic distortion (THD) as a function of audio frequency at AM standard ($V_5 = 0$).

Quasi-split sound processor for all standards

TDA3868T

APPLICATION INFORMATION



- (1) simple resonance circuit (without C_S)
- (2) resonance circuit with $C_S = 27$ pF
- $C_S = C_P (f_{VC} / f_{SC})^2 - C_P$
- $C_S = 27$ pF (Fig.3)

Fig.5 Frequency response of the 38.9 MHz reference circuit.

Quasi-split sound processor for all standards

TDA3868T

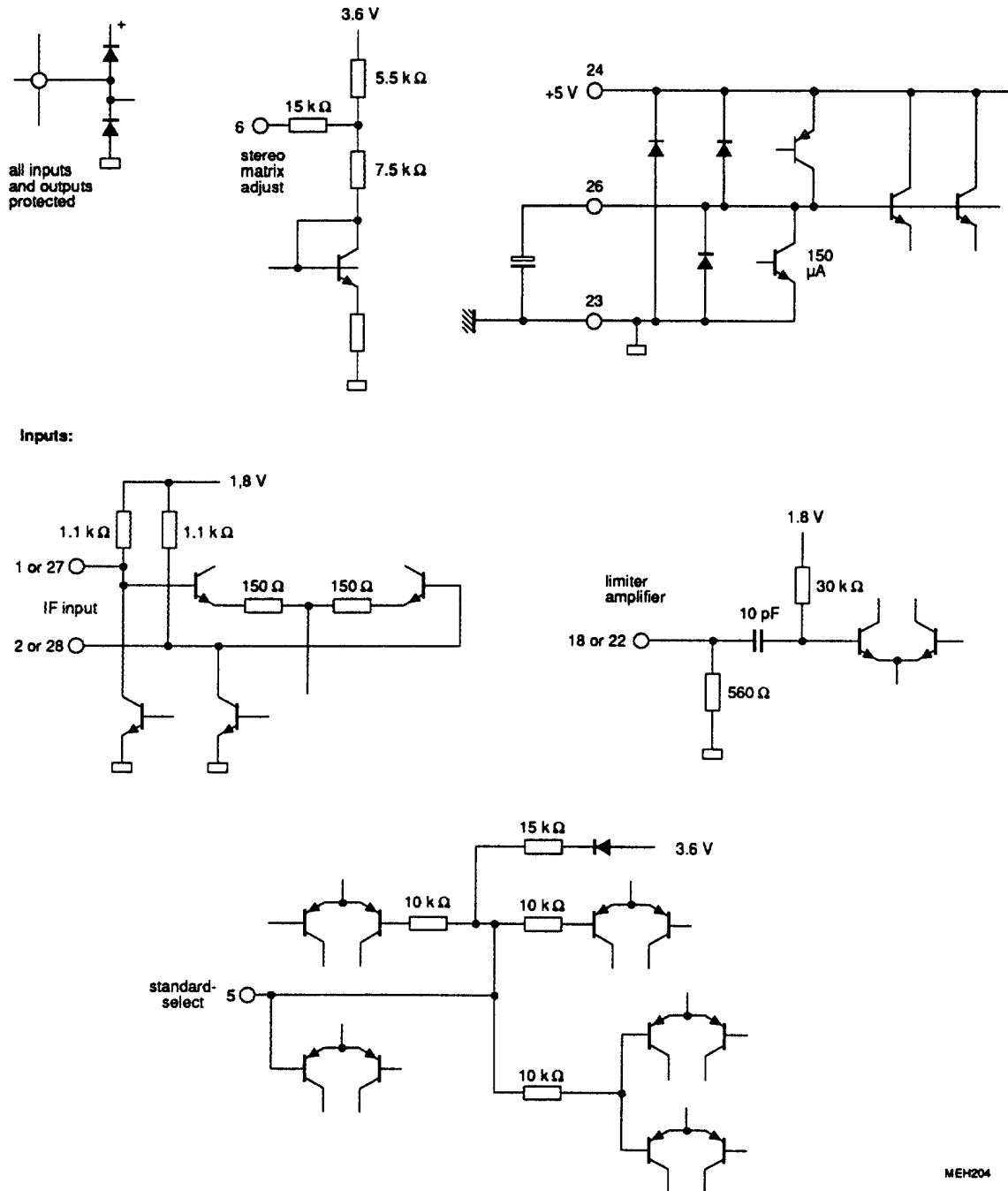
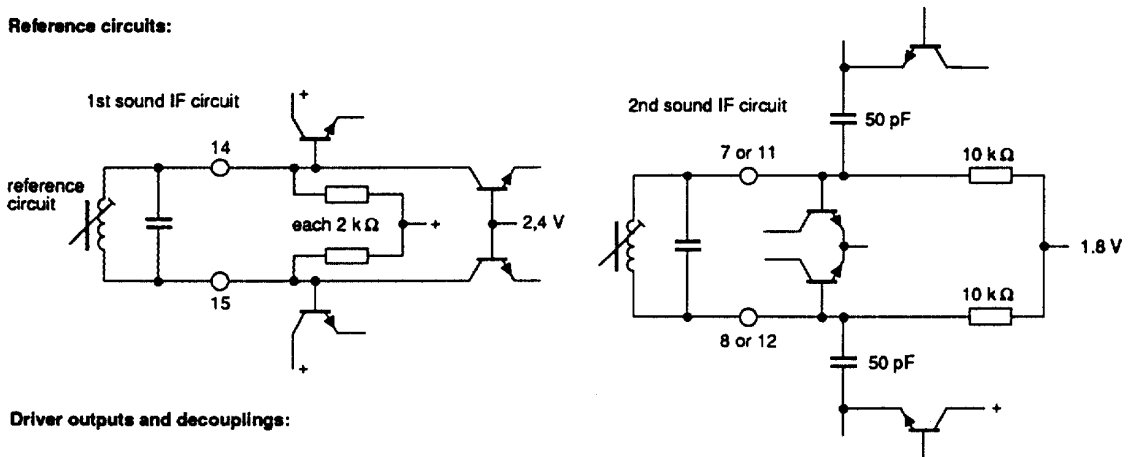

Fig.6 Internal circuits; (continued in Fig.7).

Quasi-split sound processor for all standards

TDA3868T

Reference circuits:



Driver outputs and decouplings:

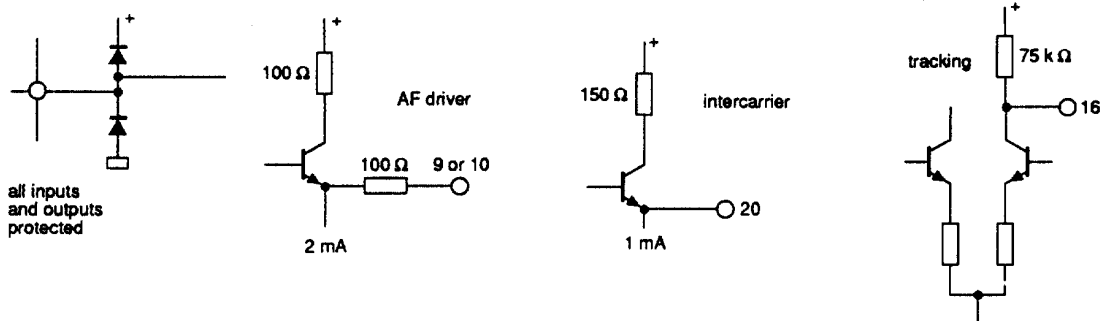

Capacitor pins:

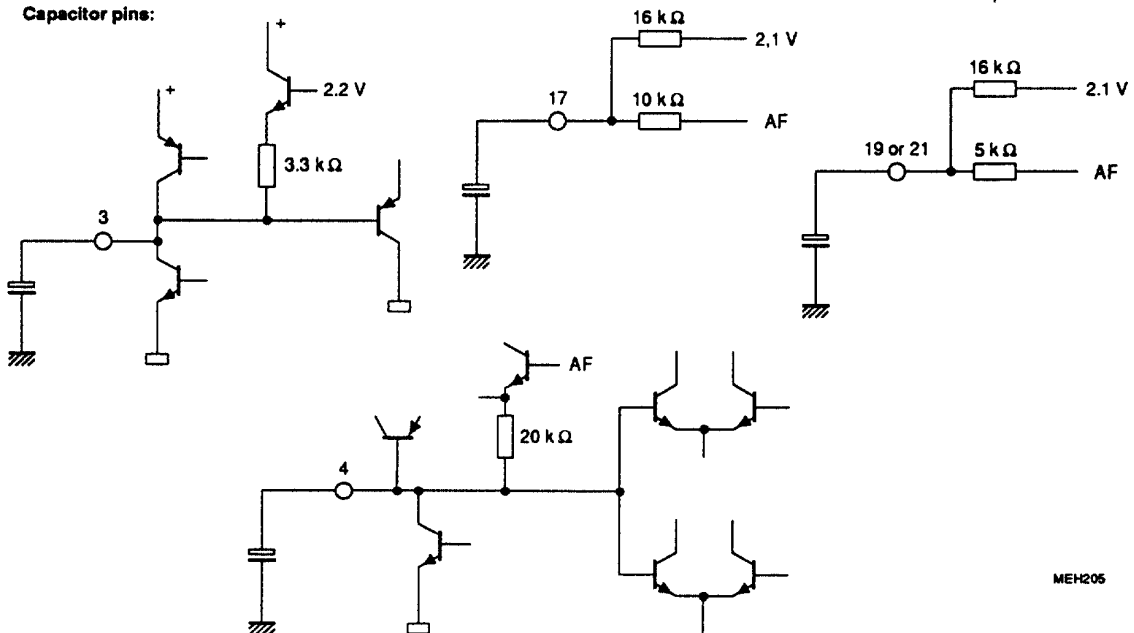

MEH205

Fig.7 Internal circuits; (continued from Fig.6).

Quasi-split sound processor for all standards

TDA3868T

PACKAGE OUTLINE

SO28: plastic small outline package; 28 leads; body width 7.5 mm

SOT136-1

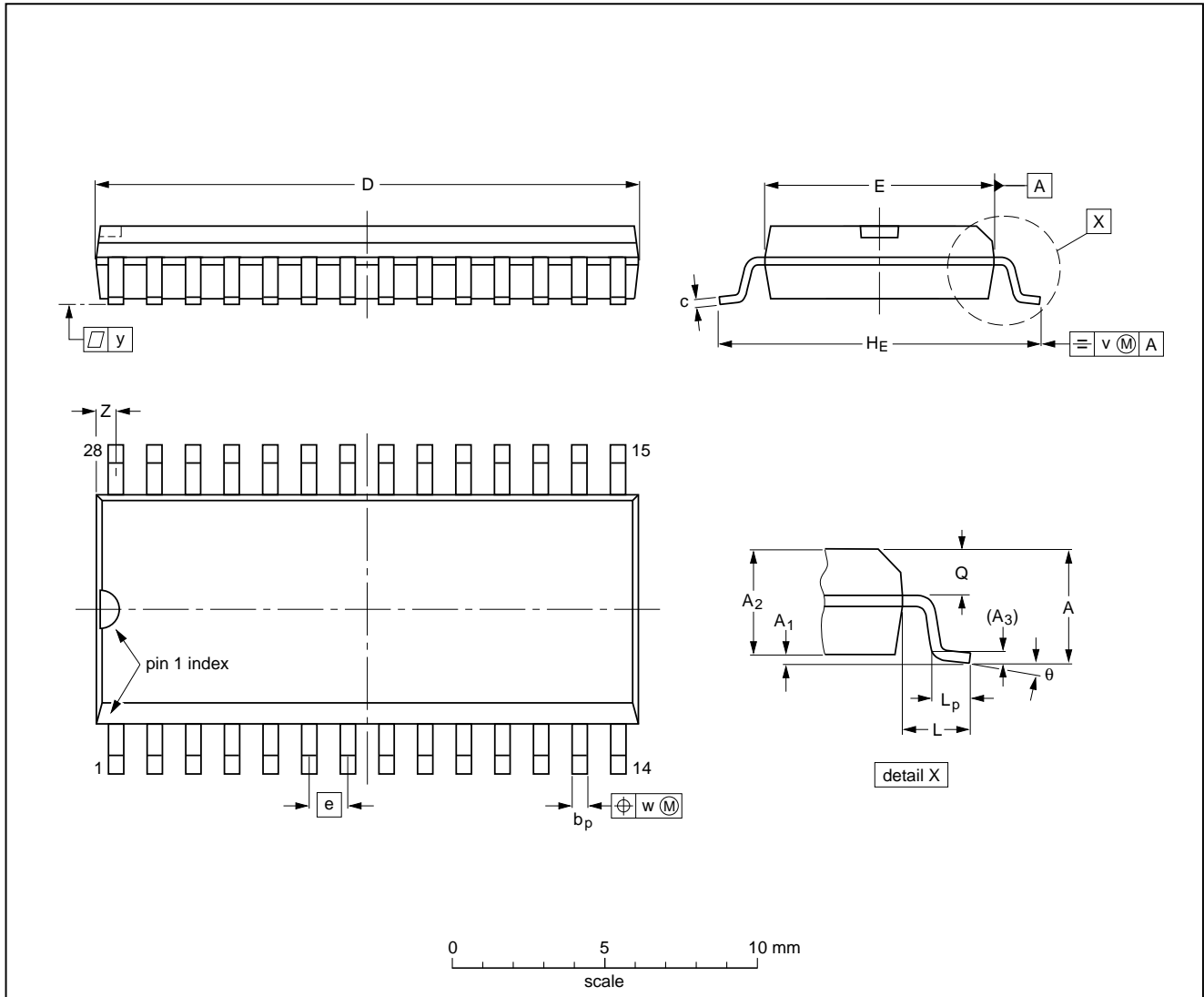

DIMENSIONS (inch dimensions are derived from the original mm dimensions)

UNIT	A max.	A ₁	A ₂	A ₃	b _p	c	D ⁽¹⁾	E ⁽¹⁾	e	H _E	L	L _p	Q	v	w	y	Z ⁽¹⁾	θ
mm	2.65	0.30 0.10	2.45 2.25	0.25	0.49 0.36	0.32 0.23	18.1 17.7	7.6 7.4	1.27	10.65 10.00	1.4	1.1 0.4	1.1 1.0	0.25	0.25	0.1	0.9 0.4	8° 0°
inches	0.10	0.012 0.004	0.096 0.089	0.01	0.019 0.014	0.013 0.009	0.71 0.69	0.30 0.29	0.050	0.42 0.39	0.055	0.043 0.016	0.043 0.039	0.01	0.01	0.004	0.035 0.016	

Note

1. Plastic or metal protrusions of 0.15 mm maximum per side are not included.

OUTLINE VERSION	REFERENCES			EUROPEAN PROJECTION	ISSUE DATE
	IEC	JEDEC	EIAJ		
SOT136-1	075E06	MS-013AE			91-08-13 95-01-24

Quasi-split sound processor for all standards

TDA3868T

SOLDERING

Introduction

There is no soldering method that is ideal for all IC packages. Wave soldering is often preferred when through-hole and surface mounted components are mixed on one printed-circuit board. However, wave soldering is not always suitable for surface mounted ICs, or for printed-circuits with high population densities. In these situations reflow soldering is often used.

This text gives a very brief insight to a complex technology. A more in-depth account of soldering ICs can be found in our "*IC Package Databook*" (order code 9398 652 90011).

Reflow soldering

Reflow soldering techniques are suitable for all SO packages.

Reflow soldering requires solder paste (a suspension of fine solder particles, flux and binding agent) to be applied to the printed-circuit board by screen printing, stencilling or pressure-syringe dispensing before package placement.

Several techniques exist for reflowing; for example, thermal conduction by heated belt. Dwell times vary between 50 and 300 seconds depending on heating method. Typical reflow temperatures range from 215 to 250 °C.

Preheating is necessary to dry the paste and evaporate the binding agent. Preheating duration: 45 minutes at 45 °C.

Wave soldering

Wave soldering techniques can be used for all SO packages if the following conditions are observed:

- A double-wave (a turbulent wave with high upward pressure followed by a smooth laminar wave) soldering technique should be used.
- The longitudinal axis of the package footprint must be parallel to the solder flow.
- The package footprint must incorporate solder thieves at the downstream end.

During placement and before soldering, the package must be fixed with a droplet of adhesive. The adhesive can be applied by screen printing, pin transfer or syringe dispensing. The package can be soldered after the adhesive is cured.

Maximum permissible solder temperature is 260 °C, and maximum duration of package immersion in solder is 10 seconds, if cooled to less than 150 °C within 6 seconds. Typical dwell time is 4 seconds at 250 °C.

A mildly-activated flux will eliminate the need for removal of corrosive residues in most applications.

Repairing soldered joints

Fix the component by first soldering two diagonally-opposite end leads. Use only a low voltage soldering iron (less than 24 V) applied to the flat part of the lead. Contact time must be limited to 10 seconds at up to 300 °C. When using a dedicated tool, all other leads can be soldered in one operation within 2 to 5 seconds between 270 and 320 °C.

 Quasi-split sound processor for all standards

TDA3868T

DEFINITIONS

Data sheet status	
Objective specification	This data sheet contains target or goal specifications for product development.
Preliminary specification	This data sheet contains preliminary data; supplementary data may be published later.
Product specification	This data sheet contains final product specifications.
Limiting values	
Limiting values given are in accordance with the Absolute Maximum Rating System (IEC 134). Stress above one or more of the limiting values may cause permanent damage to the device. These are stress ratings only and operation of the device at these or at any other conditions above those given in the Characteristics sections of the specification is not implied. Exposure to limiting values for extended periods may affect device reliability.	
Application information	
Where application information is given, it is advisory and does not form part of the specification.	

LIFE SUPPORT APPLICATIONS

These products are not designed for use in life support appliances, devices, or systems where malfunction of these products can reasonably be expected to result in personal injury. Philips customers using or selling these products for use in such applications do so at their own risk and agree to fully indemnify Philips for any damages resulting from such improper use or sale.