

SINGLE CHIP STEREO CASSETTE PLAYBACK SYSTEM

ADVANCE DATA

- WIDE OPERATING SUPPLY VOLTAGE (1.8V to 7V)
- INPUT COUPLING WITHOUT CAPACITORS
- BUILT-IN DC STEREO VOLUME CONTROL
- BUILT-IN RIPPLE FILTERS
- LOW QUIESCENT CURRENT
- NO EXTERNAL BOUCHEROT CELL
- MAX OUTPUT CURRENT 70mA PEAK

DESCRIPTION

The TDA7273 is a monolithic integrated circuit designed for portable cassette players market. It comprises preamplifiers, DC volume control, and headphone drivers.

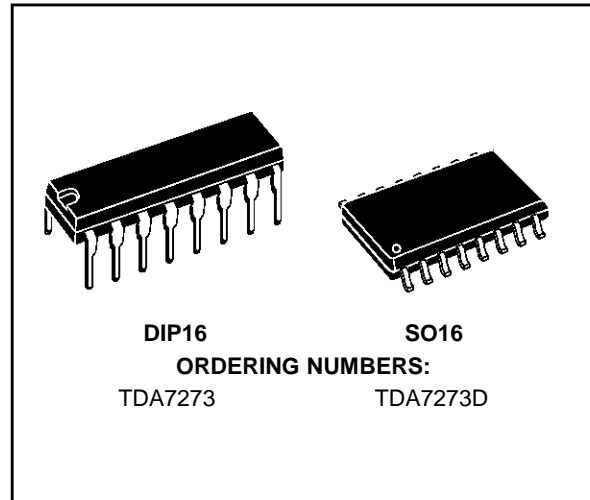

BLOCK DIAGRAM

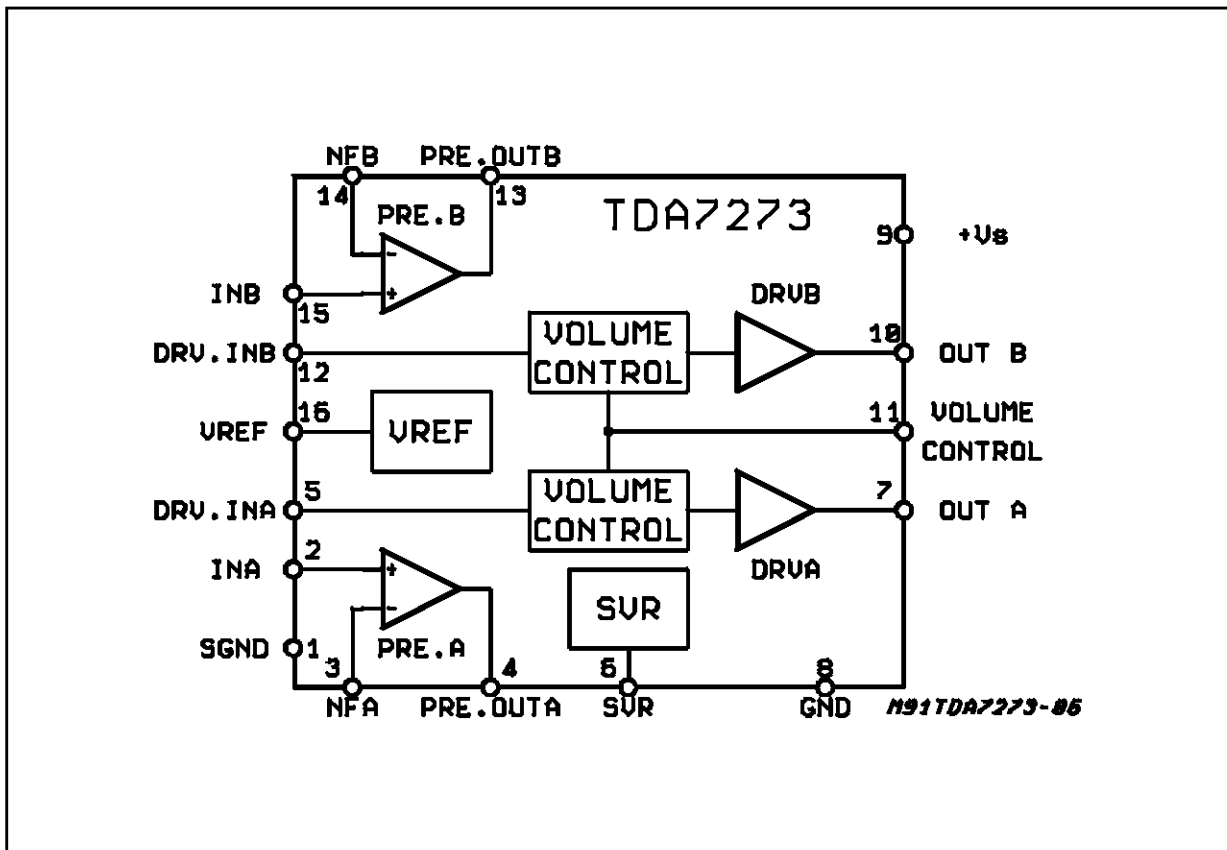

TDA7273

ABSOLUTE MAXIMUM RATINGS

Symbol	Parameter	Test Conditions	Unit
V_S	Supply Voltage	9	V
I_o	Output Current (max)	70	mA
T_{op}	Operating Temperature Range	-20 to 70	°C
T_{stg}, T_j	Storage & Junction Temperature Range	-40 to +150	°C

THERMAL DATA

Symbol	Description	DIP-16	SO-16	Unit
$R_{thj-amb}$	Thermal Resistance Junction-ambient	Max 100	200	°C/W

DC CHARACTERISTICS: $T_{amb} = 25^{\circ}\text{C}$; $V_S = 3\text{V}$; $R_L = 10\text{K}\Omega$ (Preamplifier), $R_L = 32\Omega$ (Headphone); $V_{IN} = 0$; $V_{OL} \text{ control} = V_{ref}$

Terminal No	1	2	3	4	5	6	7	8	9	10	11	12	13	14	15	16
Terminal Voltage (V)	0	1.5	1.5	1.5	1.5	2.7	1.5	0	3	1.5	1.5	1.5	1.5	1.5	1.5	1.5

TEST CIRCUIT

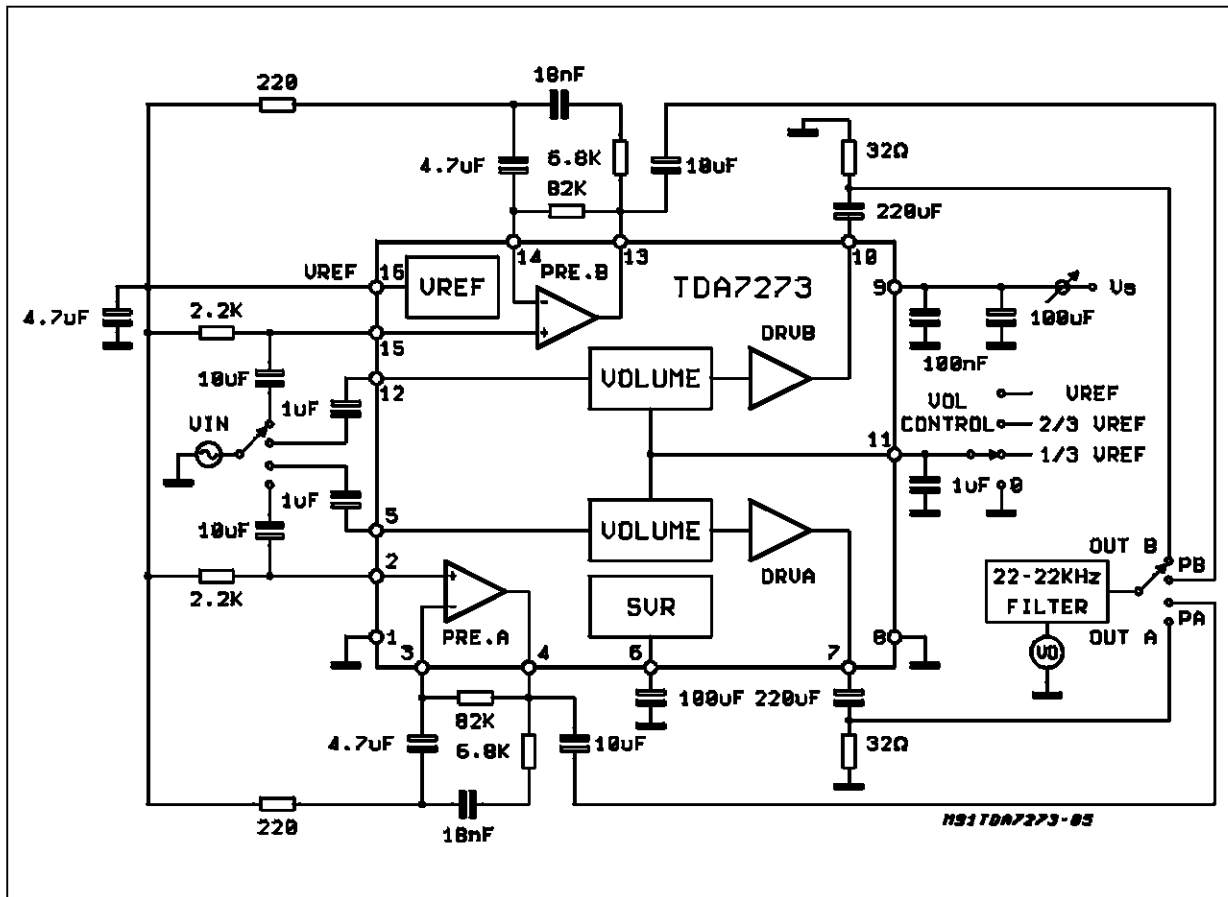

PIN CONNECTION (Top view)

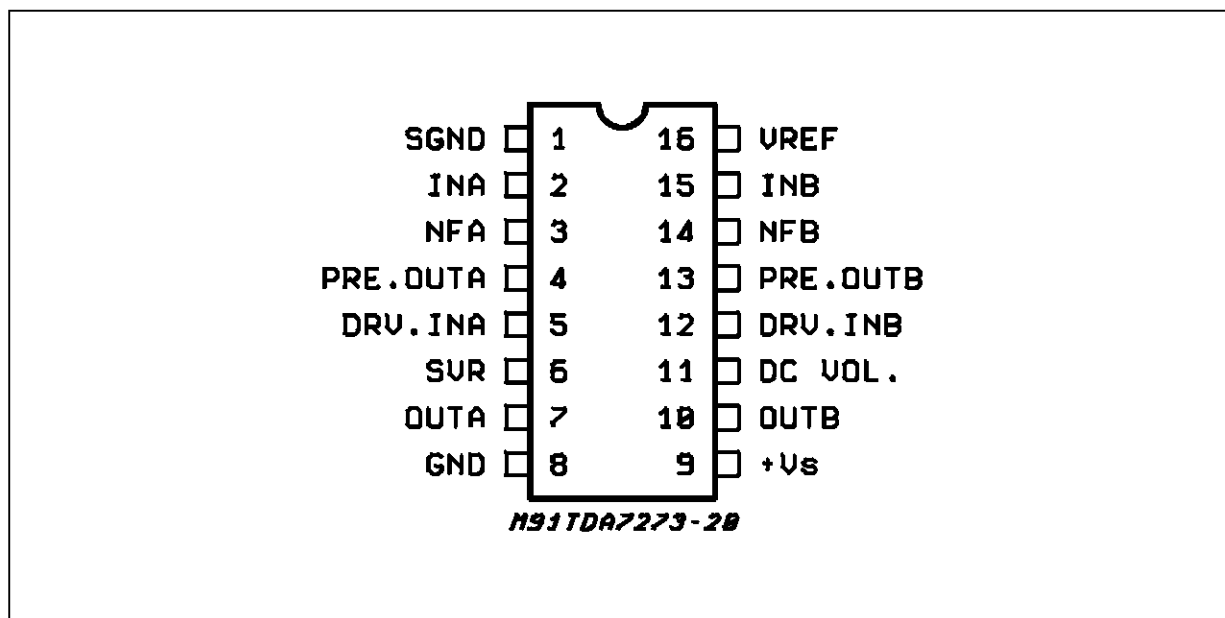

ELECTRICAL CHARACTERISTICS ($T_{amb} = 25^{\circ}\text{C}$, $V_S = 3\text{V}$, $f = 1\text{KHz}$, $R_L = 32\Omega$ Vol. control = $2/3V_{ref}$ unless otherwise specified)

Symbol	Parameter	Test Condition	Min.	Typ.	Max.	Unit
V_S	Supply Voltage		1.8		7	V
I_d	Quiescent Current			14	20	mA
V_{ref}	Reference Voltage		1.3	1.49	1.7	V

PREAMPLIFIER SECTION

G_{VO}	Open Loop Gain			70		dB
G_V	Close Loop Gain		30	33	35	dB
V_o	Output Voltage	THD = 1%	600	850		mV
I_b	Bias Current			3		μA
THD	Total Harmonic Distortion	$V_o = 330\text{mVrms}$		0.05	0.25	%
C_t	Cross Talk	$R_g = 2.2\text{K}\Omega$; $V_o = 330\text{mVrms}$		74		dB
E_N	Output Noise	$R_g = 2.2\text{K}\Omega$; BW = 22Hz to 22KHz		100		μV
SVR	Ripple Rejection	$R_g = 2.2\text{K}\Omega$ $V_R = 100\text{mVrms}$ $f = 100\text{Hz}$; $C_{SVR} = 100\mu\text{F}$	40	50		dB

HEADPHONE DRIVER

$V_{o(DC)}$	DC Output Voltage			1.50		V
P_o	Output Power	THD = 10%;	15	30		mW
P_o	Transient Output Power	THD = 10% $R_L = 16\Omega$		50		mW
G_V	Close Loop Gain	$P_o = 5\text{mW}$	28	31	34	dB
THD	Total Harmonic Distortion	$P_o = 5\text{mW}$		0.2	1	%
C_t	Cross Talk	$R_g = 10\text{K}\Omega$; $P_o = 5\text{mW}$	40	50		dB
SVR	Ripple Rejection	$V_r = 100\text{mVrms}$, $f = 100\text{Hz}$ Vol. control = $1/3V_{ref}$ $C_{SVR} = 100\mu\text{F}$; $R_g = 600\Omega$		47		dB
	Volume Control Range		66	75		dB

TDA7273

Figure 1: Application Circuit

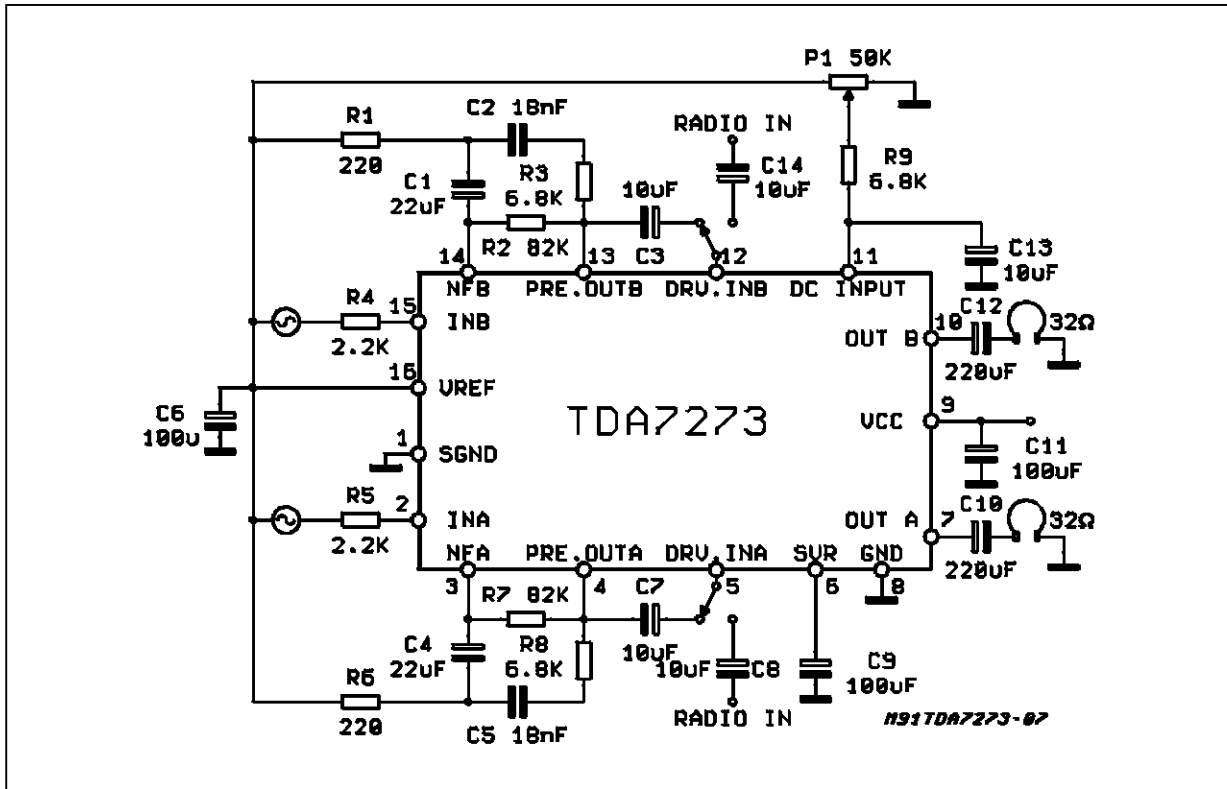

Figure 2: P.C. Board and Component Layout of the Circuit of Figure 1 (1:1 scale)

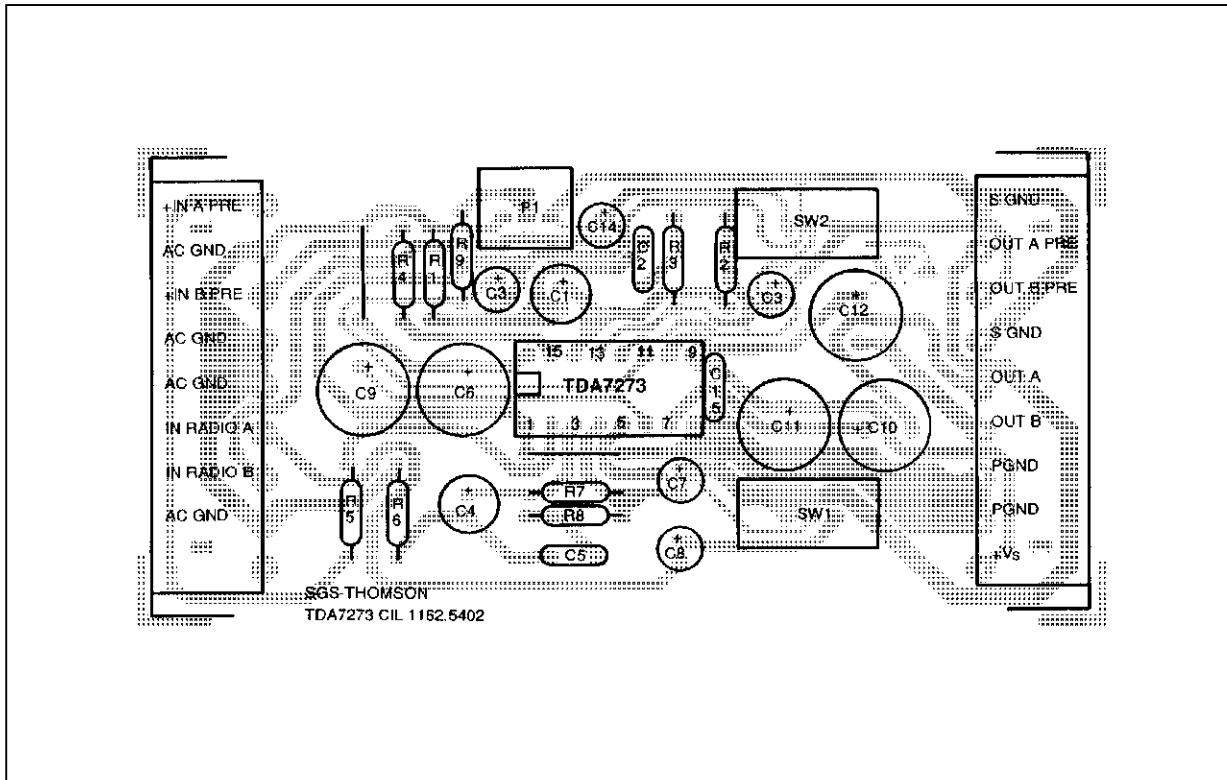

Figure 3: Supply Current vs. Supply Voltage (Preamplifier + Driver)

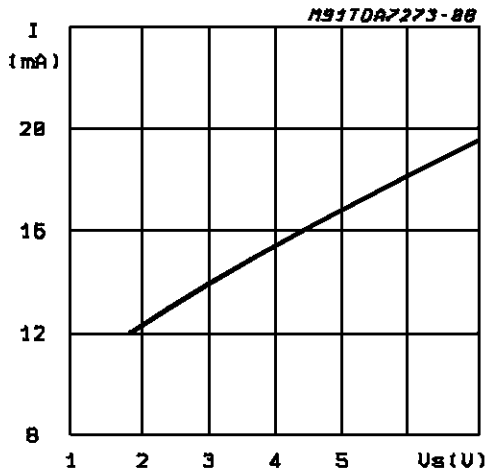

Figure 4: V_{ref} vs. Supply Voltage (pin 16)

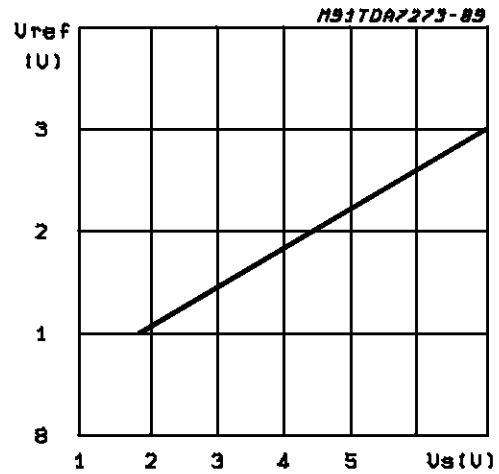

Figure 5: Closed Loop Gain vs. Frequency ($V_S = 3V$) (PREAMPLIFIER)

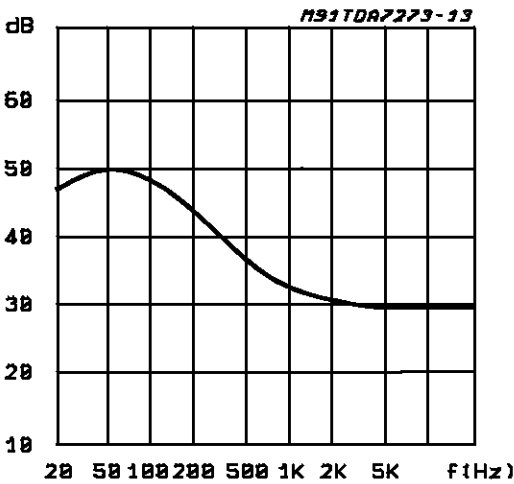

Figure 6: THD vs. Frequency ($V_S = 3V$, $V_O = 330mV_{rms}$, $R_L = 10K\Omega$) (PREAMPLIFIER)

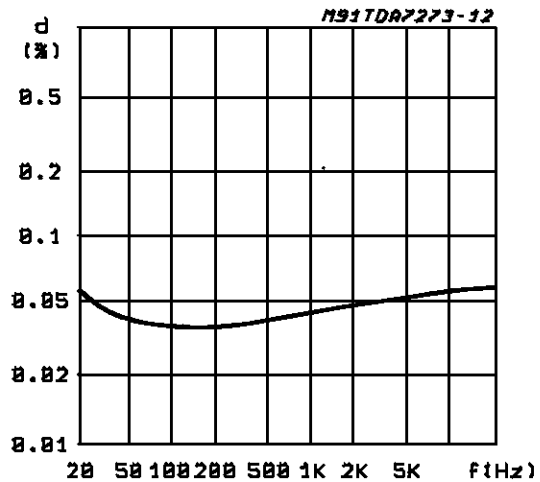

Figure 7: SVR vs. Frequency (PREAMPLIFIER)

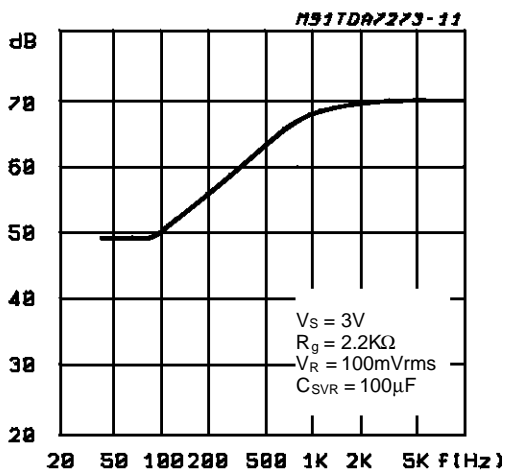

Figure 8: Quiescent Output Voltage vs. Supply Voltage (DRIVER)

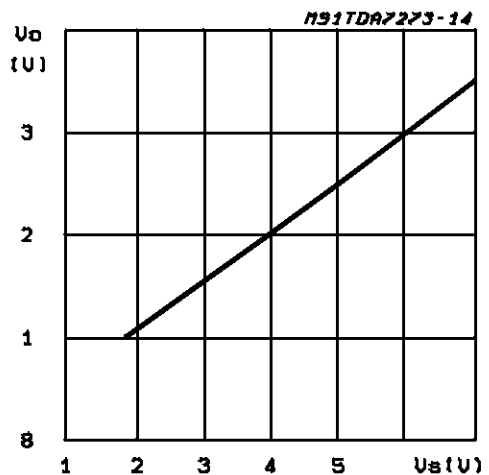

Figure 9: Closed Loop Gain vs Frequency ($V_S = 3V, R_L = 32\Omega$) (DRIVER)

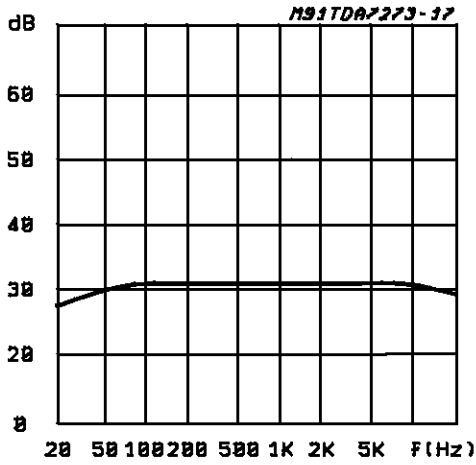

Figure 10: Output Power vs. Supply Voltage ($V_{ol} = 2/3V_{ref}, R_L = 32\Omega, THD = 10\%, f = 1KHz$) (DRIVER)

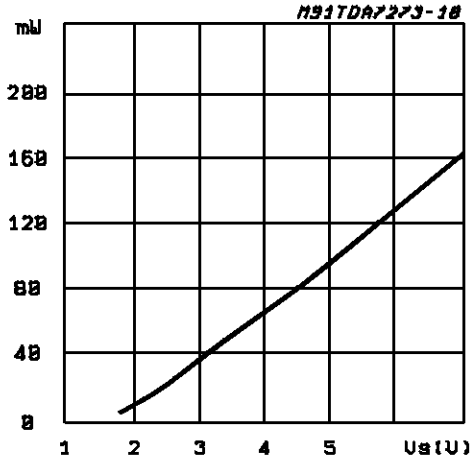

Figure 11: THD vs. Output Power ($V_o = 2/3V_{ref}, V_S = 3V, R_L = 32\Omega, f = 1KHz$) (DRIVER)

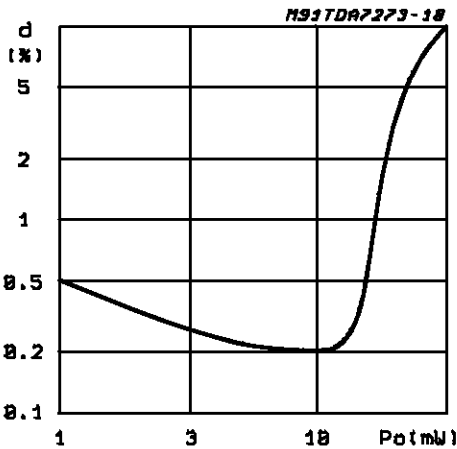

Figure 12: THD vs. Frequency ($P_o = 5mW, V_S = 3V, R_L = 32\Omega$) (DRIVER)

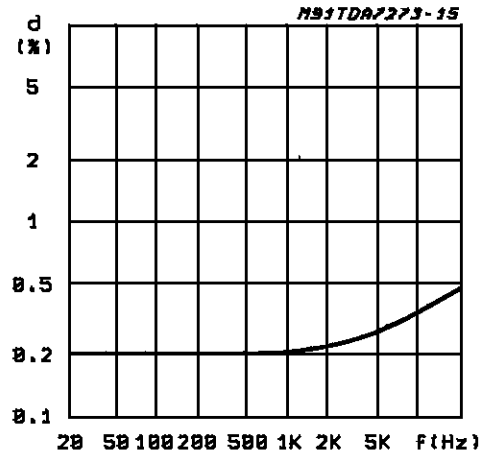

Figure 13: SVR vs. Frequency ($V_S = 3V, R_L = 32\Omega, V_r = 100V_{rms}, R_g = 600\Omega, C_{SVR} = 100mV$) (DRIVER)

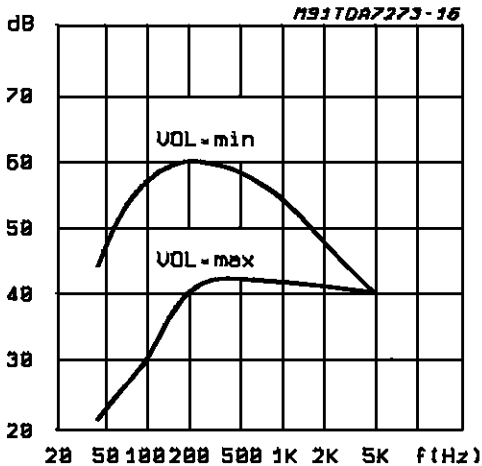
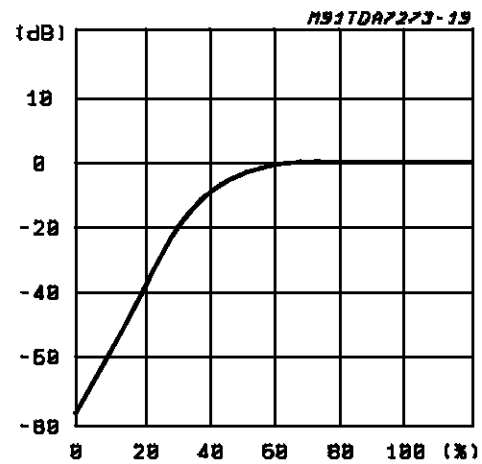
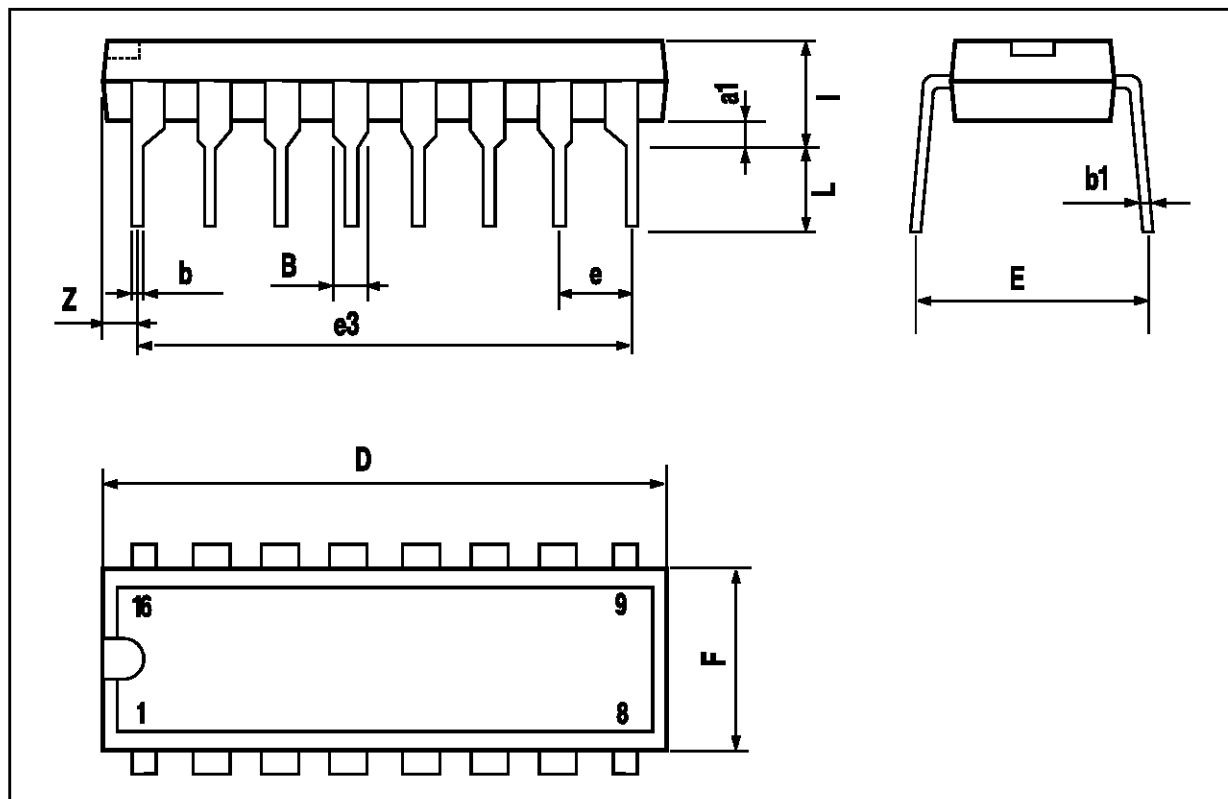

Figure 14: Volume Control ($0dB = 10mW, V_S = 3V, R_{vol} = 50K\Omega, R_L = 32\Omega, f = 1KHz$) vs. Volume Setting (DRIVER)



DIP16 PACKAGE MECHANICAL DATA

DIM.	mm			inch		
	MIN.	TYP.	MAX.	MIN.	TYP.	MAX.
a1	0.51			0.020		
B	0.77		1.65	0.030		0.065
b		0.5			0.020	
b1		0.25			0.010	
D			20			0.787
E		8.5			0.335	
e		2.54			0.100	
e3		17.78			0.700	
F			7.1			0.280
I			5.1			0.201
L		3.3			0.130	
Z			1.27			0.050



SO16 PACKAGE MECHANICAL DATA

DIM.	mm			inch		
	MIN.	TYP.	MAX.	MIN.	TYP.	MAX.
A			2.65			0.104
a1	0.1		0.2	0.004		0.012
a2			2.45			0.096
b	0.35		0.49	0.014		0.019
b1	0.23		0.32	0.009		0.013
C		0.5			0.020	
c1	45° (typ.)					
D	10.1		10.5	0.398		0.413
E	10.0		10.65	0.394		0.419
e		1.27			0.050	
e3		8.89			0.350	
F	7.4		7.6	0.291		0.299
L	0.5		1.27	0.020		0.050
M			0.75			0.030
S	8° (max.)					

