

**MOTOR SPEED REGULATOR**

ADVANCE DATA

- EXCELLENT VERSATILITY IN USE
- HIGH OUTPUT CURRENT (up to 1.5 A)
- LOW QUIESCENT CURRENT
- LOW REFERENCE VOLTAGE (1.32 V)
- EXCELLENT PARAMETERS STABILITY VERSUS AMBIENT TEMPERATURE
- START/STOP FUNCTION (TTL levels)
- DUMP PROTECTION

**DESCRIPTION**

The TDA7275A is a linear integrated circuit in mini-dip plastic package. It is intended for use as speed regulator for DC motors of record players, tape and cassette recorders.

The dump protection make it particularly suitable for car radio applications.

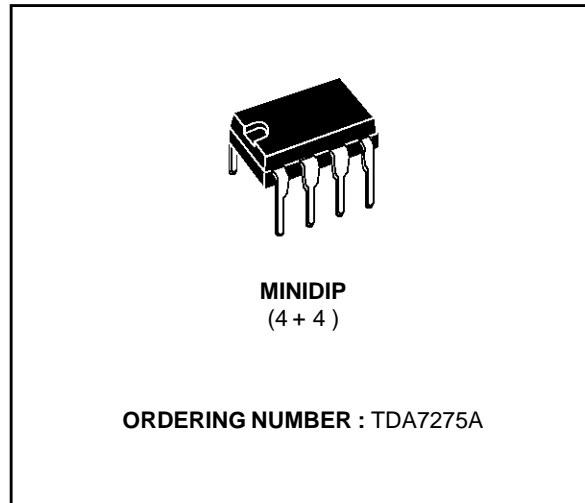

**PIN CONNECTION (top view)**

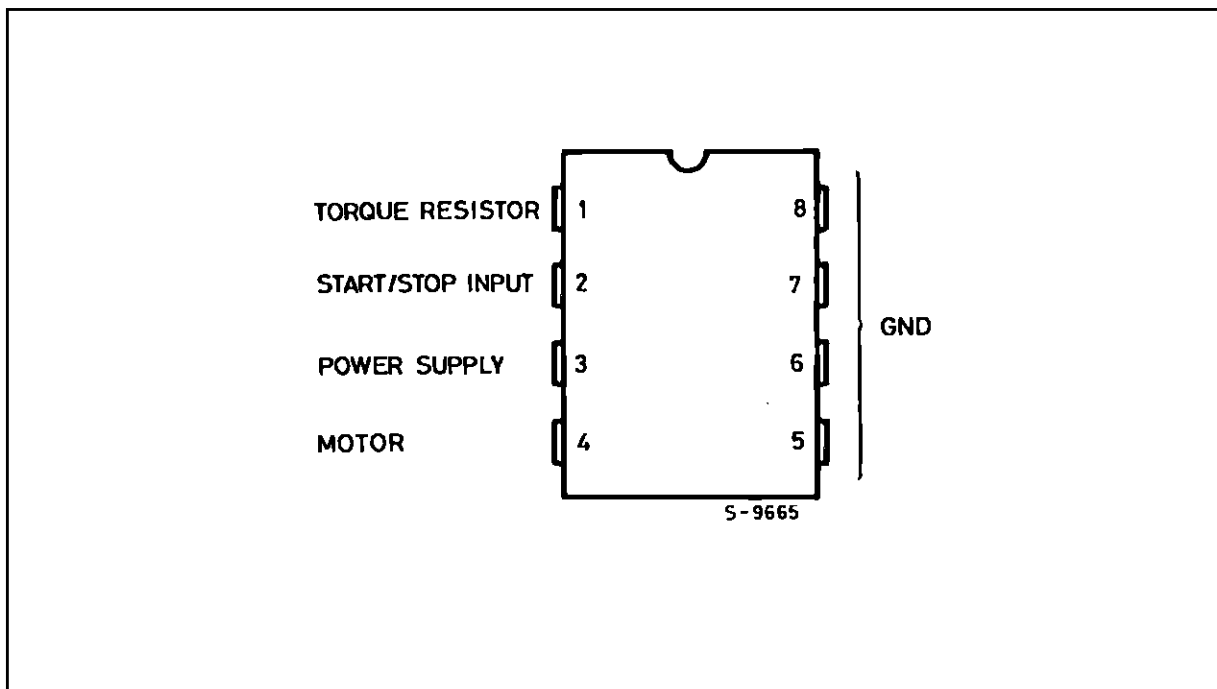

**SCHEMATIC DIAGRAM**

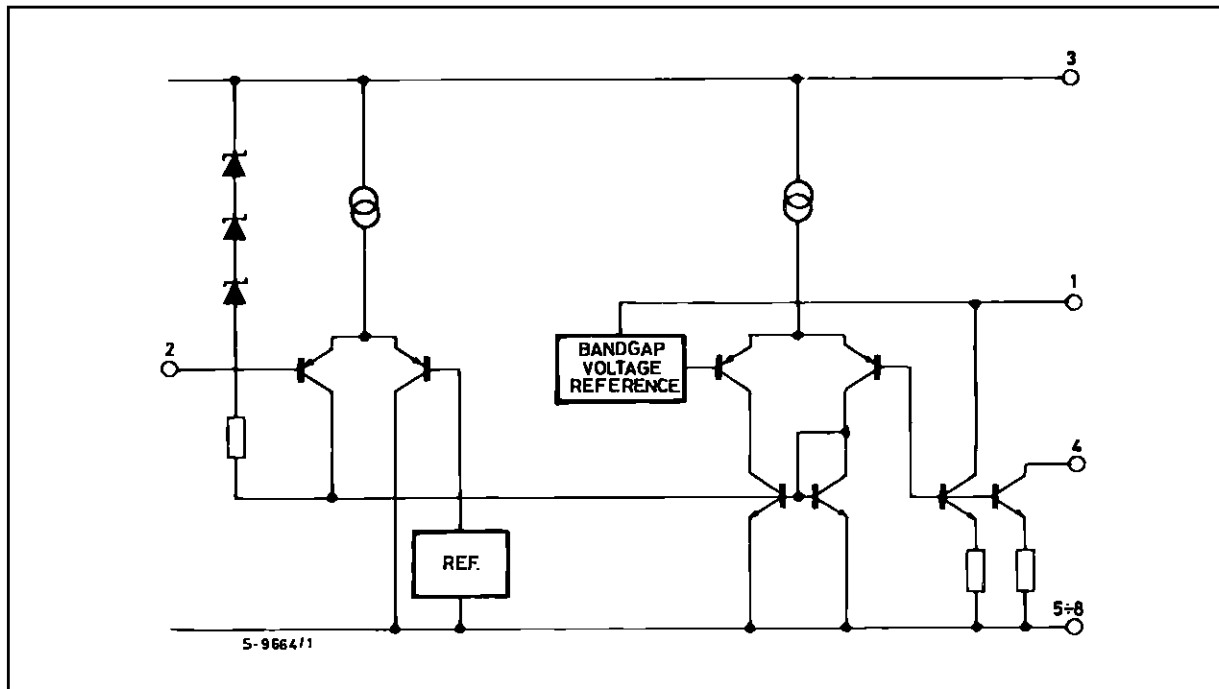

**ABSOLUTE MAXIMUM RATINGS**

Symbol	Parameter	Value	Unit
$V_S$	Supply Voltage	19	V
$V_S$	Peak Supply Voltage (for 50ms)	45	V
$I_M$	Maximum Output Current	1.5	A
$T_{op}$	Operating Temperature Range	-30 to +85	°C
$P_{tot}$	Power Dissipation at $T_{amb} = 70^\circ\text{C}$	1	W
	at $T_{pins} = 70^\circ\text{C}$	4	W

**THERMAL DATA**

Symbol	Parameter	Value	Unit
$R_{th\ j-amb}$	Thermal Resistance Junction-ambient	80	°C/W
$R_{th\ j-pins}$	Max.	20	°C/W
	Thermal Resistance Junction -pins	Max.	

**ELECTRICAL CHARACTERISTICS** (Refer to test circuit,  $V_S = 12V$ ,  $T_{amb} = 25^\circ C$  unless otherwise specified, refer to test circuit)

Symbol	Parameter	Test Condition	Min.	Typ.	Max.	Unit
$V_S$	Supply Voltage Range		8		18	V
$V_{ref}$	Reference Voltage	$I_M = 0.1A$	1.05	1.22	1.35	V
$I_q + I_d$	Total Quiescent Current	$I_M = 0.1mA$		2		mA
$I_d$	Quiescent Current	$I_M = 0.1mA$		1		mA
$I_{ms}$	Starting Motor Current	$\frac{\Delta V_{ref}}{V_{ref}} = -50\%$	1			A
$V_4$	Saturation Voltage	$I_M = 0.5A$		1.7	2	V
$K = I_M/I_T$	Reflection coefficient	$I_M = 0.1A$	18	20	22	–
$\frac{\Delta K/\Delta V_S}{K}$		$I_M = 0.1A$ $V_S = 8 \text{ to } 16V$		0.5		%/V
$\frac{\Delta K/\Delta I_M}{K}$		$I_M = 25 \text{ to } 200mA$		–0.05		%/mA
$\frac{\Delta K/\Delta T}{K}$		$I_M = 0.1A$ $T_{op} = -30 \text{ to } +85^\circ C$		0.02		%/°C
$\frac{\Delta V_{ref}/\Delta V_S}{V_{ref}}$	Line Regulation	$I_M = 0.1A$ $V_S = 8 \text{ to } 16V$		0.04		%/V
$\frac{\Delta V_{ref}/\Delta I_M}{V_{ref}}$	Load Regulation	$I_M = 25 \text{ to } 200mA$		–0.01		%/mA
$\frac{\Delta V_{ref}/\Delta T}{V_{ref}}$	Temperature Coefficient	$I_M = 0.1A$ $T_{op} = -30 \text{ to } +85^\circ C$		0.02		%/°C
$V_2$	Motor "Stop" (Acc. Following data or grounded)			1		V
$I_2$	Motor "Stop"	$V_2 = 1V$		–0.05		mA
$V_2$	Motor "Run" (Acc. Following data or open)			1.5		V
$I_2$	Motor "Run"	$V_2 = 1.5V$		–0.1		mA

# TDA7275A

Figure 1 : Test Circuit.

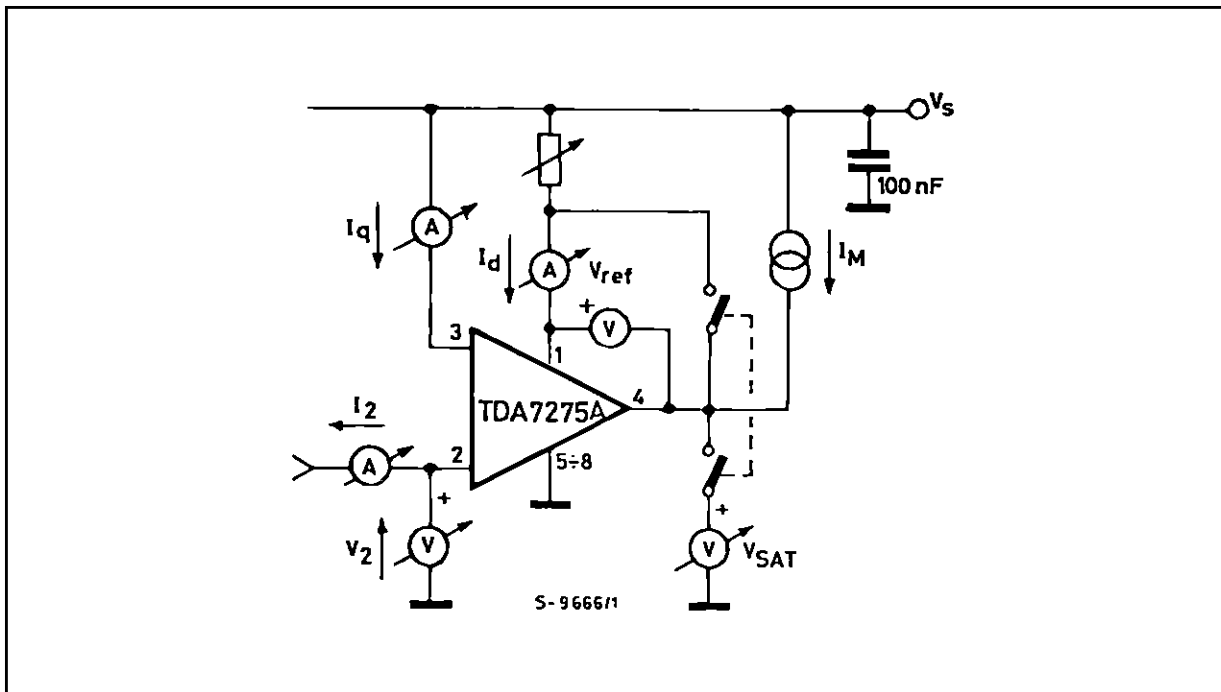
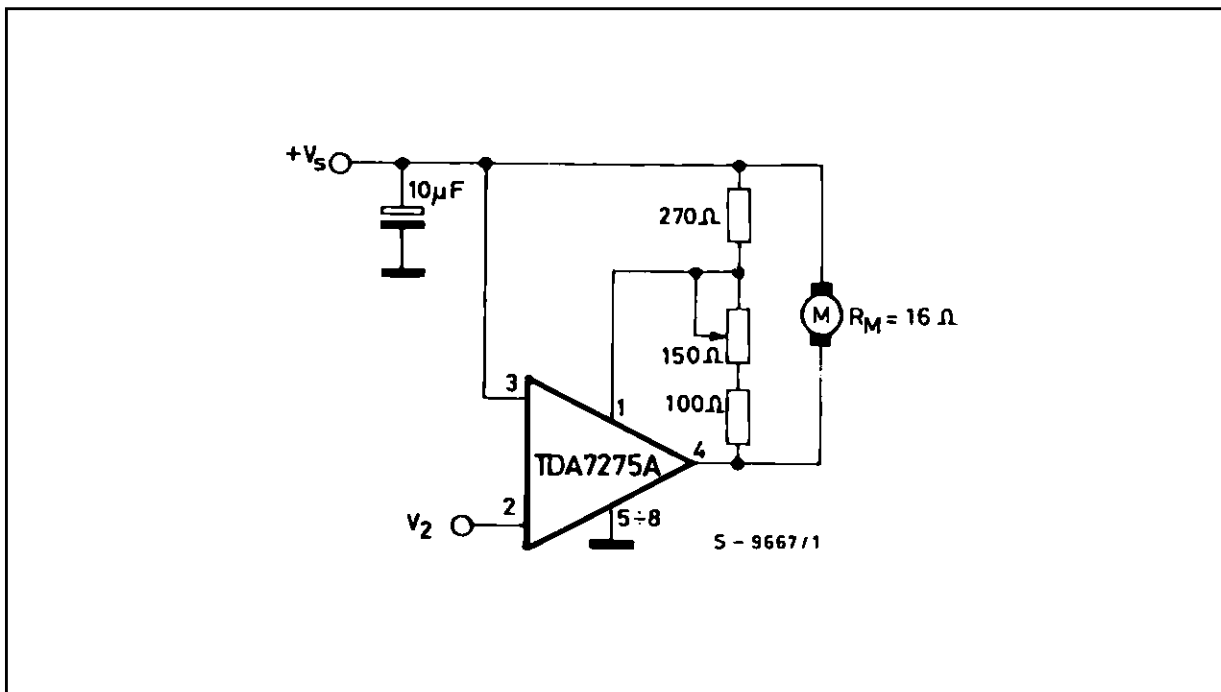
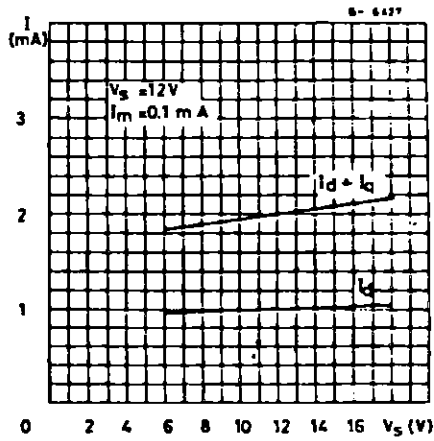

Figure 2 : Application Circuit.



- $R_{Ttyp.} = K_{typ.} R_{Mtyp.}$  if  $R_T > K_{min} R_{Mmin}$  instability may occur.
- A diode across the motor could be necessary with certain kind of motor.

**Figure 3 :** Quiescent Current vs. Supply voltage.



**Figure 4 :** Speed Variation vs. Supply Voltage.

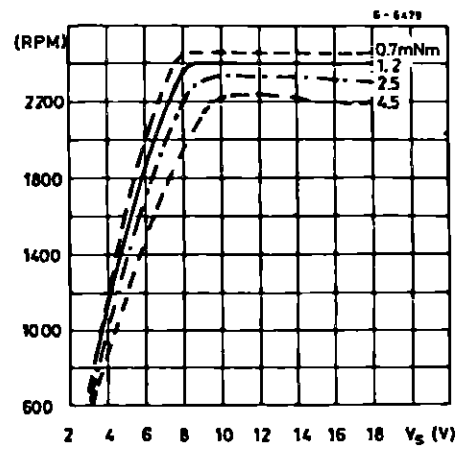

**Figure 5 :** Speed Variation vs. Torque ( $V_S = 12V$ ).

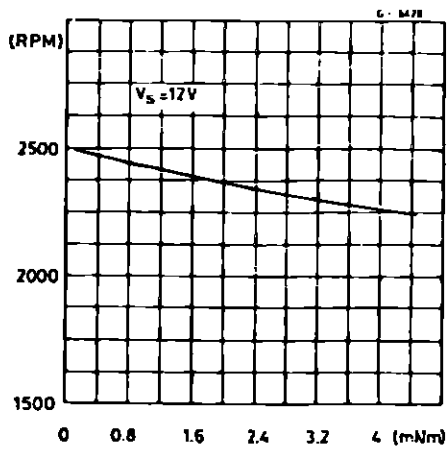

MINIDIP PACKAGE MECHANICAL DATA

DIM.	mm			inch		
	MIN.	TYP.	MAX.	MIN.	TYP.	MAX.
A		3.3			0.130	
a1	0.7			0.028		
B	1.39		1.65	0.055		0.065
B1	0.91		1.04	0.036		0.041
b		0.5			0.020	
b1	0.38		0.5	0.015		0.020
D			9.8			0.386
E		8.8			0.346	
e		2.54			0.100	
e3		7.62			0.300	
e4		7.62			0.300	
F			7.1			0.280
I			4.8			0.189
L		3.3			0.130	
Z	0.44		1.6	0.017		0.063

