

**RECORD/PLAYBACK CIRCUIT WITH ALC**

ADVANCE DATA

- WIDE OPERATING SUPPLY VOLTAGE (3V to 12V)
- VERY LOW INPUT NOISE ( $V_i = 1.2\mu\text{V}$ )
- INTERNAL COMPENSATION FOR HIGH GAIN APPLICATION (DOUBLE SPEED RECORDING)
- BUILT-IN ALC CIRCUITRY
- GOOD SVR
- DC CONTROLLED SWITCHES FOR MUTE OR EQUALIZATION SWITCHING FUNCTIONS

**DESCRIPTION**

The TDA7284 is a monolithic integrated circuit in a DIP/SO-14 designed for 6V, 9V and 12V AC/DC portable cassette equipment application.

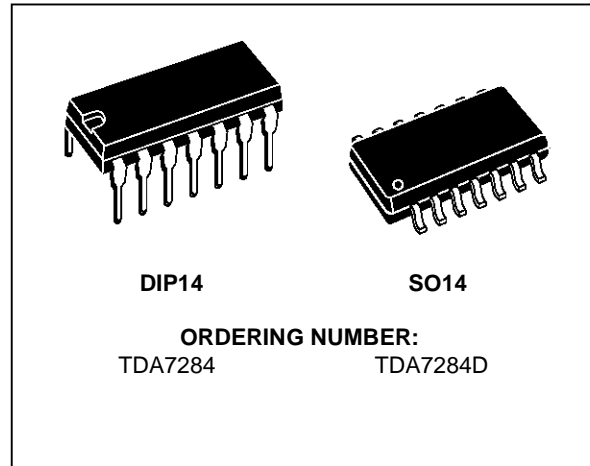

**BLOCK DIAGRAM**

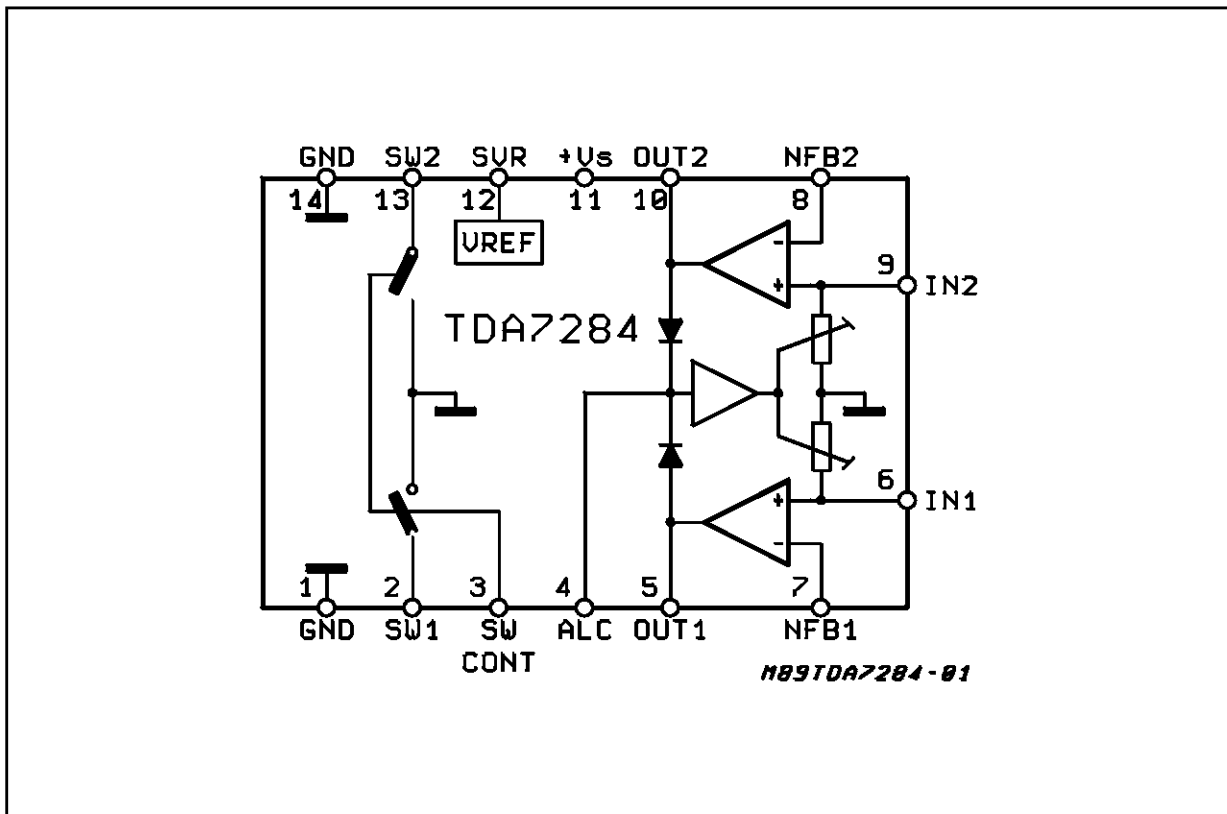

## TDA7284

### PIN CONNECTION (Top view)

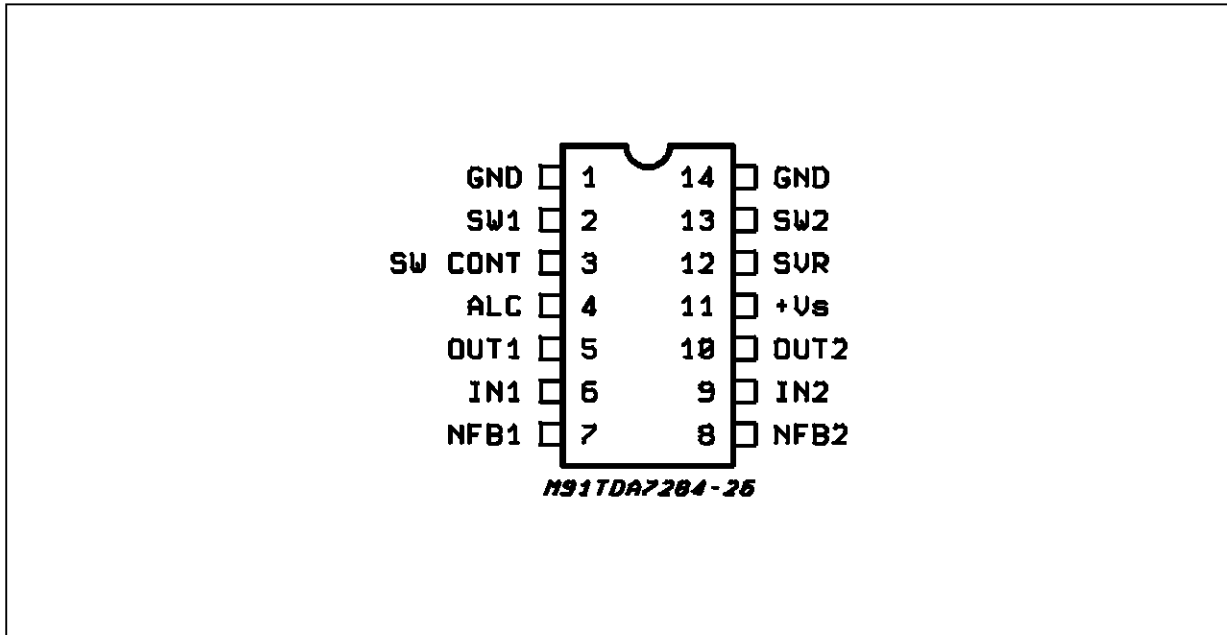

### ABSOLUTE MAXIMUM RATINGS

| Symbol         | Parameter                              | Value      | Unit |
|----------------|--|------------|------|
| $V_S$          | Supply Voltage                         | 14         | V    |
| $T_{OP}$       | Operating Temperature Range            | -20 to 70  | °C   |
| $T_{stg}, T_j$ | Storage and Junction Temperature Range | -40 to 150 | °C   |

### THERMAL DATA

| Symbol          | Description                         |     | S014 | DIP14 | Unit |
|-----------------|-------------------------------------|-----|------|-------|------|
| $R_{th\ j-amb}$ | Thermal Resistance Junction-ambient | Max | 200  | 120   | °C/W |

### DC CHARACTERISTICS ( $T_{amb} = 25^\circ$ ; $V_S = 6V$ ; $V_i = 0V$ ; $R_i = 10K\Omega$ ; ALC = OFF)

| Terminal No.         | 1 | 2 | 3 | 4 | 5   | 6 | 7   | 8   | 9 | 10  | 11 | 12  | 13 | 14 |
|----------------------|---|---|---|---|-----|---|-----|-----|---|-----|----|-----|----|----|
| Terminal Voltage (V) | 0 | 0 | 0 | 0 | 2.6 | 0 | 1.3 | 1.3 | 0 | 2.6 | 6  | 4.6 | 0  | 0  |

Figure 1: Test and Application Circuit

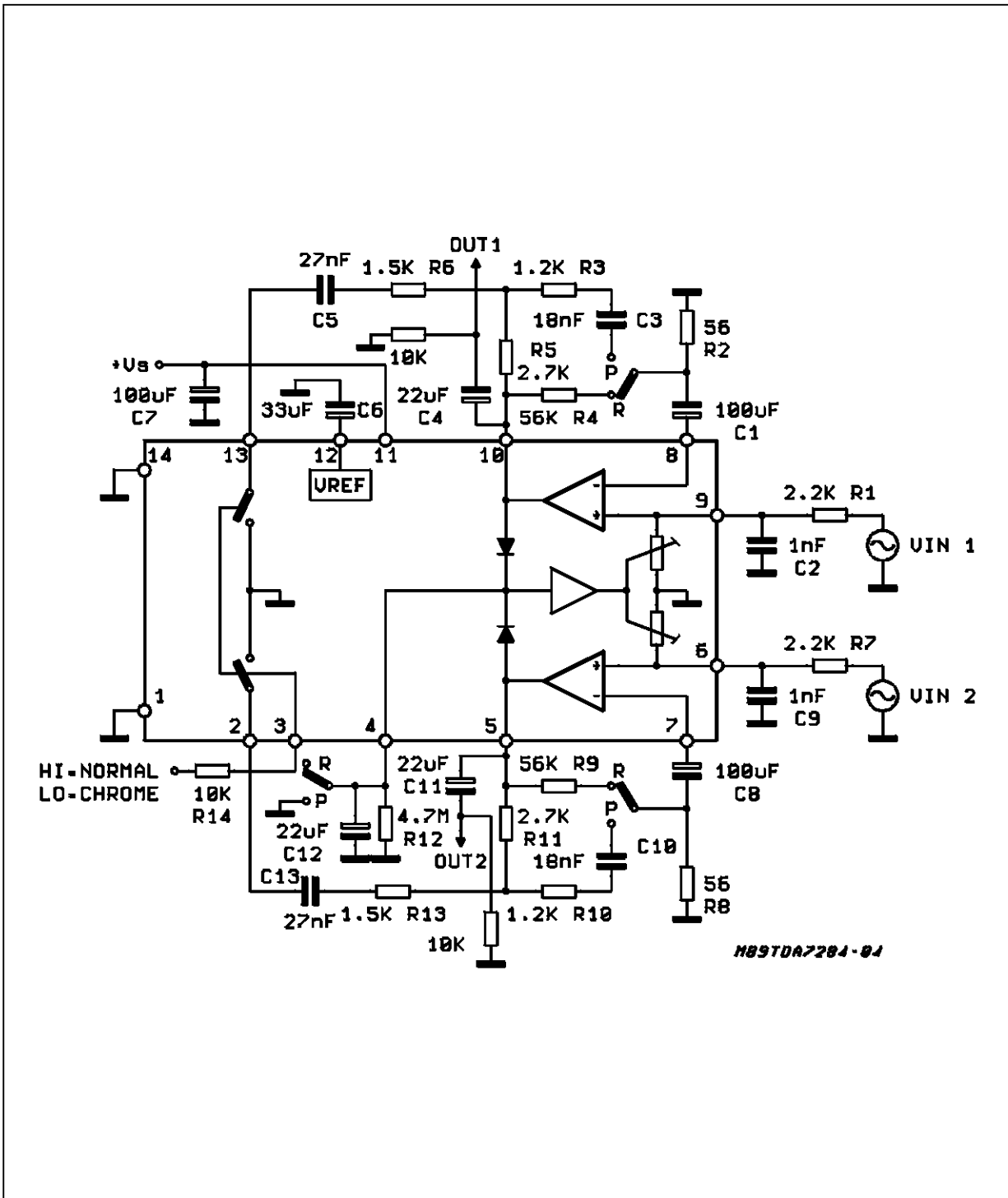
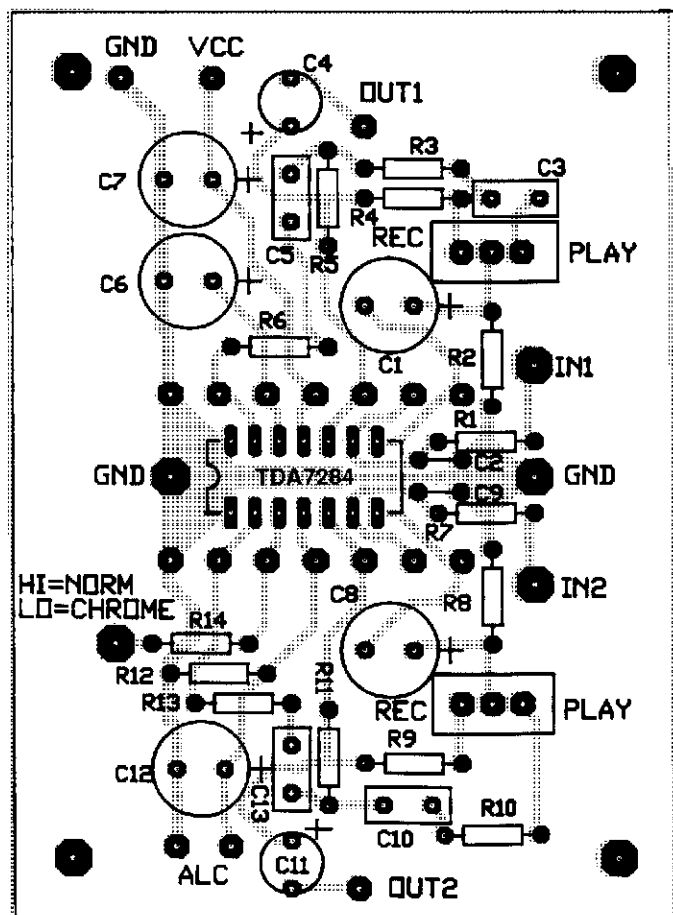

Figure 2: P.C. Board and Component Layout of the Circuit of Fig. 1 (1:1 scale).



**ELECTRICAL CHARACTERISTICS** ( $V_S = 6V$ ,  $T_{amb} = 25^\circ C$  unless otherwise specified refer to test circuit)

| Symbol | Parameter                 | Test Condition  | Min.       | Typ.       | Max.     | Unit                   |
|--------|---------------------------|---|------------|------------|----------|------------------------|
| $V_S$  | Supply Voltage            |   | 3          |            | 12       | V                      |
| $I_d$  | Quiescent Current         |   |            | 4.5        | 8        | mA                     |
| $E_n$  | Input Noise               | $R_g = 2.2K\Omega$<br>$BW = 22Hz$ to $22kHz$  |            | 1.2        |          | $\mu V$                |
| $R_I$  | Input Resistance          |   | 30         | 50         | 70       | $K\Omega$              |
| $G_O$  | Open Loop Gain            |   | 65         | 78         |          | dB                     |
| $V_O$  | Output Voltage            | THD $\leq 1\%$<br>ALC OFF<br>ALC ON   | 1.2<br>0.7 | 1.8<br>0.9 | 1.1      | $V_{rms}$<br>$V_{rms}$ |
| THD    | Total Harmonic Distortion | $V_O = 1V_{rms}$<br>ALC = ON $V_I = 100mV$  |            | 0.1<br>0.3 | 0.5<br>1 | %<br>%                 |
|        | ALC Range                 | $\Delta V_O = 3dB$  |            | 47         |          | dB                     |
| CB     | Channel Balance           | ALC ON  |            | 0          | 2        | dB                     |
| SVR    | Supply Voltage Rejection  | $f = 120Hz$ , $C_{SVR} = 33\mu F$<br>$V_R = 100mV$ , $R_g = 10K\Omega$<br>ALC = Off |            | 50         |          | dB                     |
| CS     | Cross-talk                | ALC OFF   |            | 70         |          | dB                     |
| Pin 3  | Turn Off Threshold        | $I_O = <1\mu A$   | 0.8        | 1.3        |          | V                      |
| Pin 3  | Turn On Threshold         |   |            | 1.7        | 2.25     | V                      |
| Pin 3  | Turn On Saturation        | $R_L = 10K\Omega$   |            | 0.1        | 0.2      | V                      |

**Figure 3:** Drain Current vs. Supply Voltage

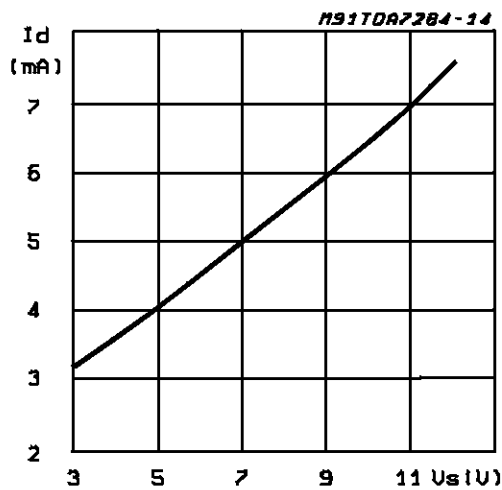

**Figure 4:** Recording Closed Loop Gain vs. Frequency

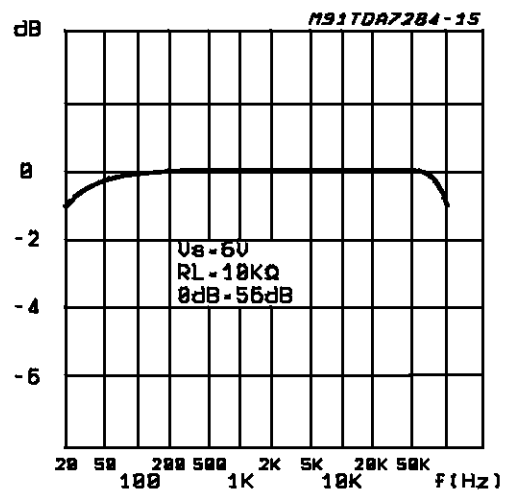

Figure 5: Playback Closed Loop Gain vs Frequency

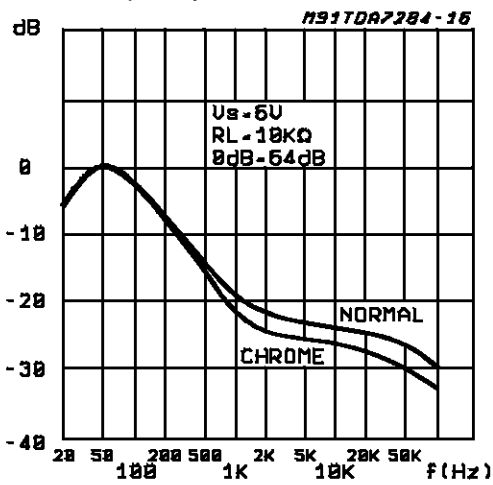

Figure 7: Output Voltage vs. Input Voltage

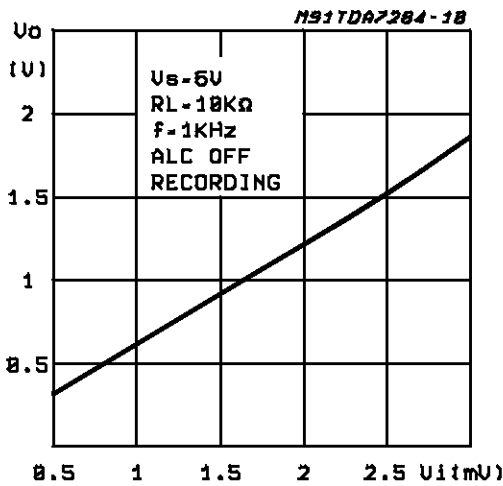

Figure 9: Output Voltage vs. Input Voltage

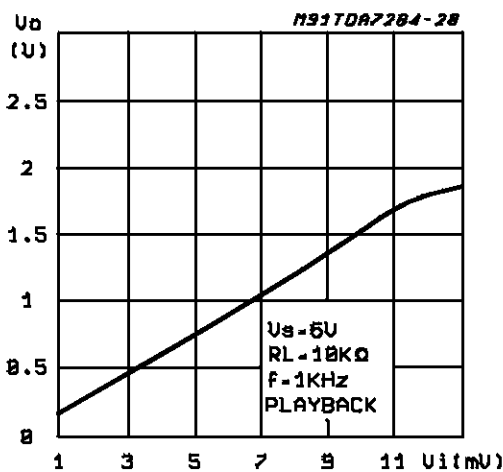

Figure 6: Normalized Output Voltage vs. Supply Voltage

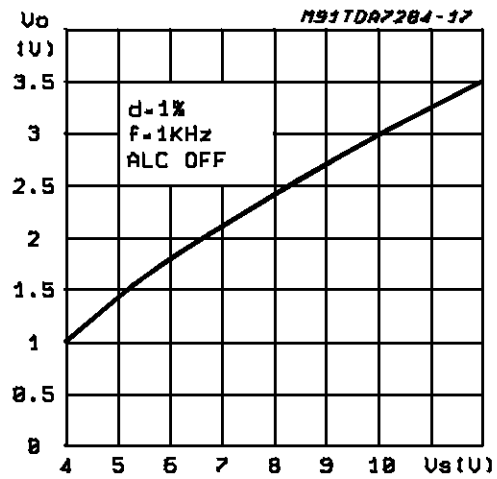

Figure 8: Output Voltage vs. Input Voltage

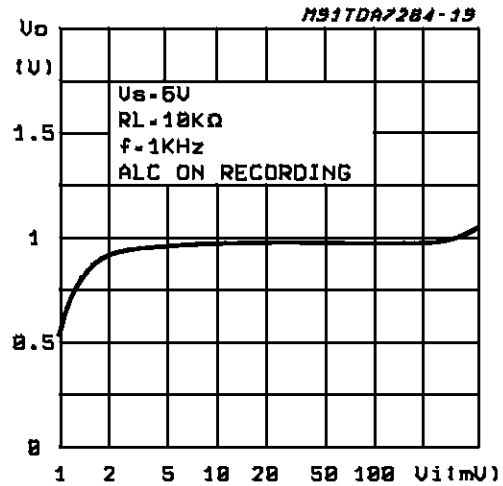

Figure 10: Distortion vs. Input Voltage

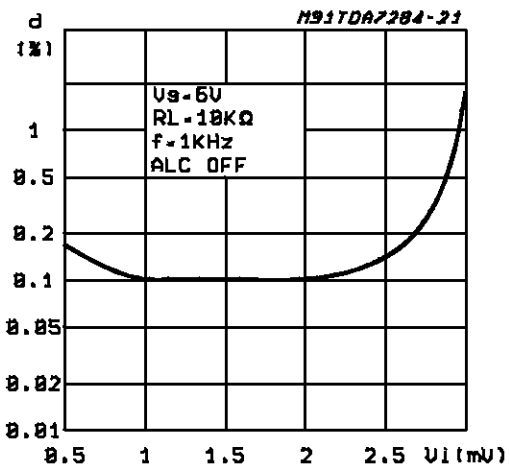

Figure 11: Distortion vs. Input Voltage

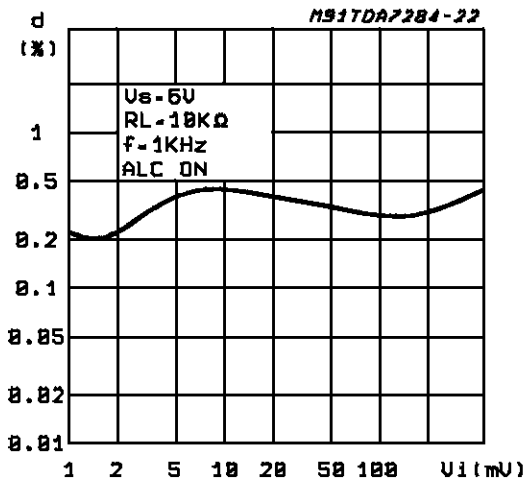

Figure 12: SVR vs. Frequency (ALC = Off)

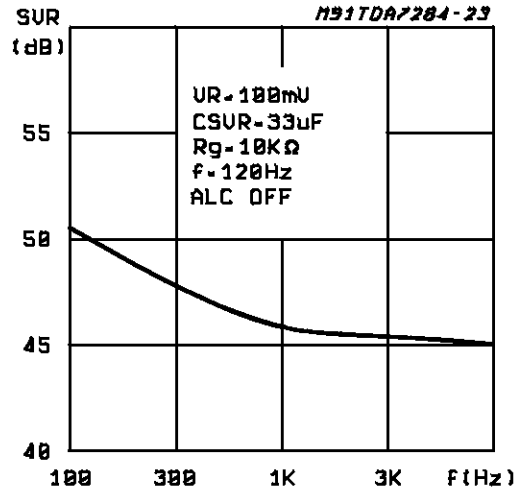

Figure 13: Crosstalk vs. Frequency (ALC = Off)

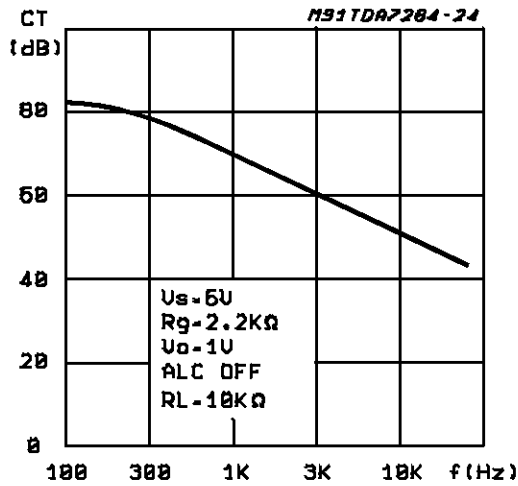
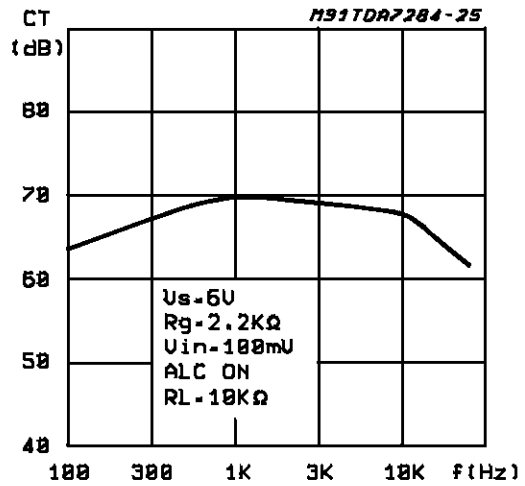

Figure 14: Crosstalk vs. Frequency (ALC = Off)



**CIRCUIT DESCRIPTION**

**OPERATIONAL AMPLIFIER**

The operational amplifier consists essentially of a very low noise input stage decoupled from the

single-ended output stage by means of an emitter follower (fig. 15 ).

The compensations provided in order to have high gain bandwidth product allowing the use for double speed recording application.

**Figure 15**

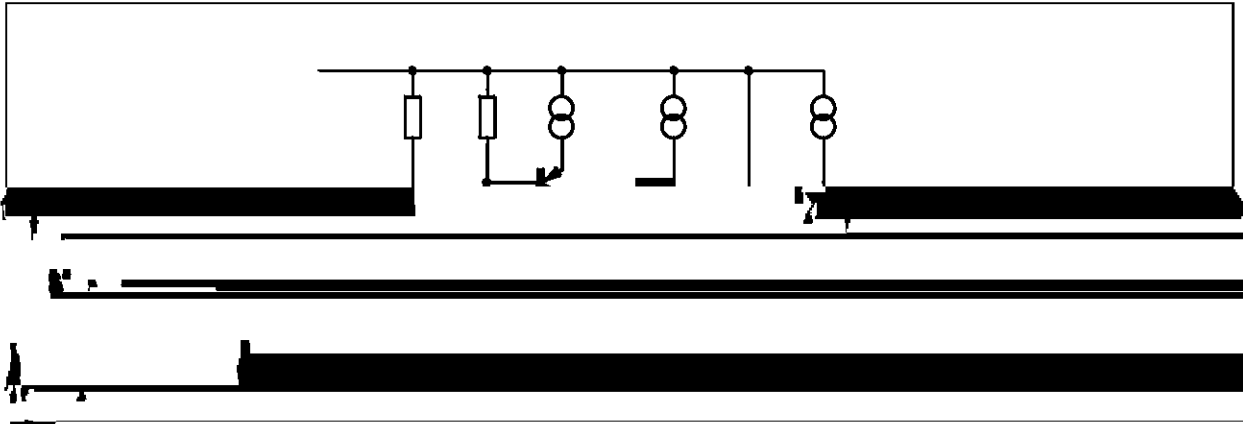

recorded at a level which prevents saturation of the tape and which optimizes the signal to noise ratio even there are notable variations in the input signal.

Before presenting the ALC circuit of TDA7284 it is worth describing the operation of the automatic level control as a system. A diagram showing the basis of operation is given in fig. 16.

**Figure 16:** Basic Diagram of the ALC stage

by means of a peak-to-peak detector) into a continuous voltage which drives the networks indicated by T and Rd.

The element T transforms the continuous voltage level into a signal capable of modifying the circuit conditions symbolized by variable resistor Rd.

The value assumed by the resistor Rd is a function of the output signal level Vo and is such that the voltage Vc at the input of the op amp is constant, even variations of Vi are present. Obviously if Vo is less than a certain value the system is not controlled.

In this case :

$$V_i = V_c = V_o / G_v$$

(Gv is the gain of the op-amp)

For the TDA7284 the value of Vo below which the system is not controlled is around 1 Vrms.

Let us now consider the speed of response of the system (when controlled) to positive and negative changes of the input signal i.e. the limiting time, the time for return to nominal level (1 Vrms) and the recovery time.

**Limiting time, and time for return to nominal level.**



**Figure 17: Limiting and Level Setting Time**

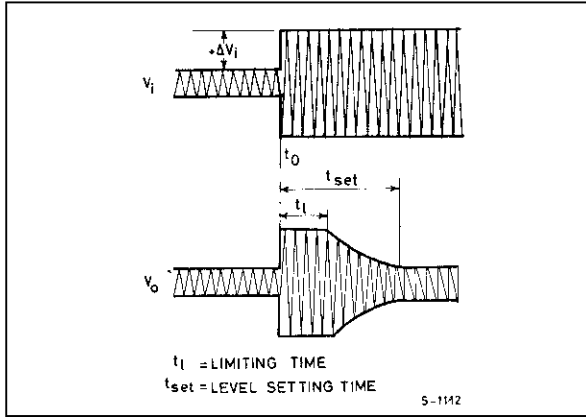

Usually such an increase drives the op-amp into saturation and the time for which it remains in this condition is called the limiting time ( $T_1$ ).

$T_1$  depends on the relationship between the external capacitances, the time constant  $T=R_1 \cdot C_1$ , the supply voltage and the signal variation.

The criteria for choosing the length of  $T_1$  are the result of several compromises. In particular if  $T_1$  is too long, there will be audible distortion during playback (during  $T_1$  the output is a square wave), and if it is too short, the sensation of increased level will be lost while dynamic compression phenomena and instability may occur.

The time for return to nominal level is defined as the total time between the instant  $T_0$  and the instant in which the output reassumes the nominal value. This time ( $T_s$ ) is roughly equal to  $5 \cdot T_1$ .

On the basis of tests carried out it has been found that a musical signal with high dynamic range

( $\Delta V_i = +40 \text{ dB}$ ) is to be recorded, the best value of  $T_s$  is between 200 and 300ms.

**Recovery time.**

let us now suppose that at the instant  $T_0$  the input signal decreases of  $\Delta V_i$  (fig. 18).

**Figure 18: Recovery Time**

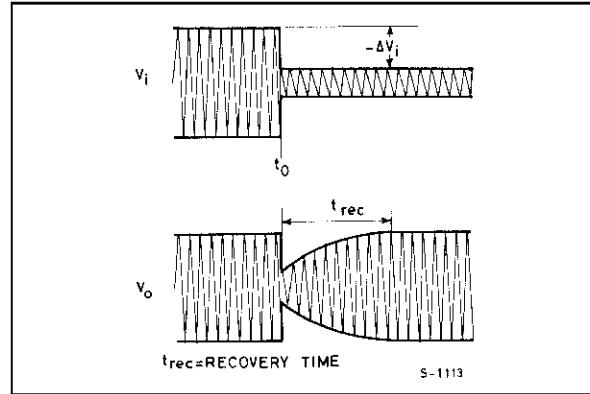

The recovery time ( $T_{rec}$ ) is defined as the time between the instant  $T_0$  and the instant in which the output signal returns to the nominal level.

This time depends essentially on the discharge time constant of  $R_2 \cdot C_2$  ( see fig. 16) and on the size of the step  $-\Delta V_i$ . In this case too, if this time is too long the signal to noise ratio on the tape deteriorates.

If it is too short the sensation of the low signal level is lost during playback.

**The ALC system of the TDA7284**

Fig. 16 becomes the following (fig. 19) where the

**Figure 19**

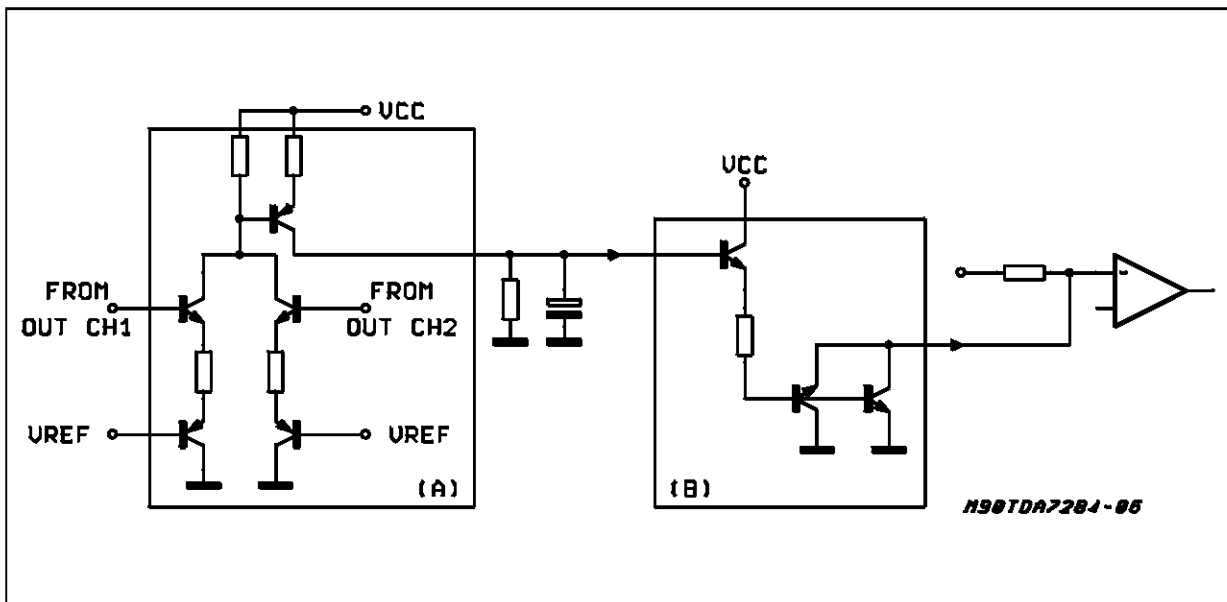

## TDA7284

peak-to-peak detector of fig. 16 is now inside the broken line 1 while the system which allows a dynamic resistance varying with the DC voltage level (i.e. inversely proportional to the op-amp output signal), is inside the broken line 2.

It should be noted that the generator resistance  $R_i$  has no influence on the controlled voltage value  $V_c$ , although its value should be between 1 and 47 Kohm.

The lower limit is determined by the minimum dynamic resistance of 10 ohm and therefore to have a control range of 40 dB for the input signal,  $R_i$  must be greater than 1.5 Kohm.

The upper limit results from the necessity to limit the attenuation of the signal by the input impedance of the op-amp.

### Switches

Two DC-controlled switches are also included in the chip (fig. 20)

Fig. 19 shows the typical application circuit of the TDA7284 utilizing the equalization switch for normal or chrome tape playback equalization. The advantage is the components can be placed near

Figure 20

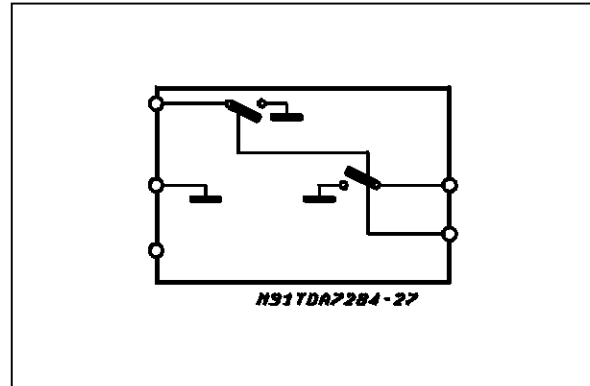

to the IC, while the tape selector switch can be at a remote location, hence reduce the chances of noise and oscillation due to components layout. Another advantage is that only one pole is needed for the tape selector switch as compared to the two poles needed by conventional circuits (one separate pole for each channel).

Fig. 22 shows the use of the switches to obtain the mute function.

Figure 21: Application Circuit with DC Switching of Normal/Chrome Tape Equalization

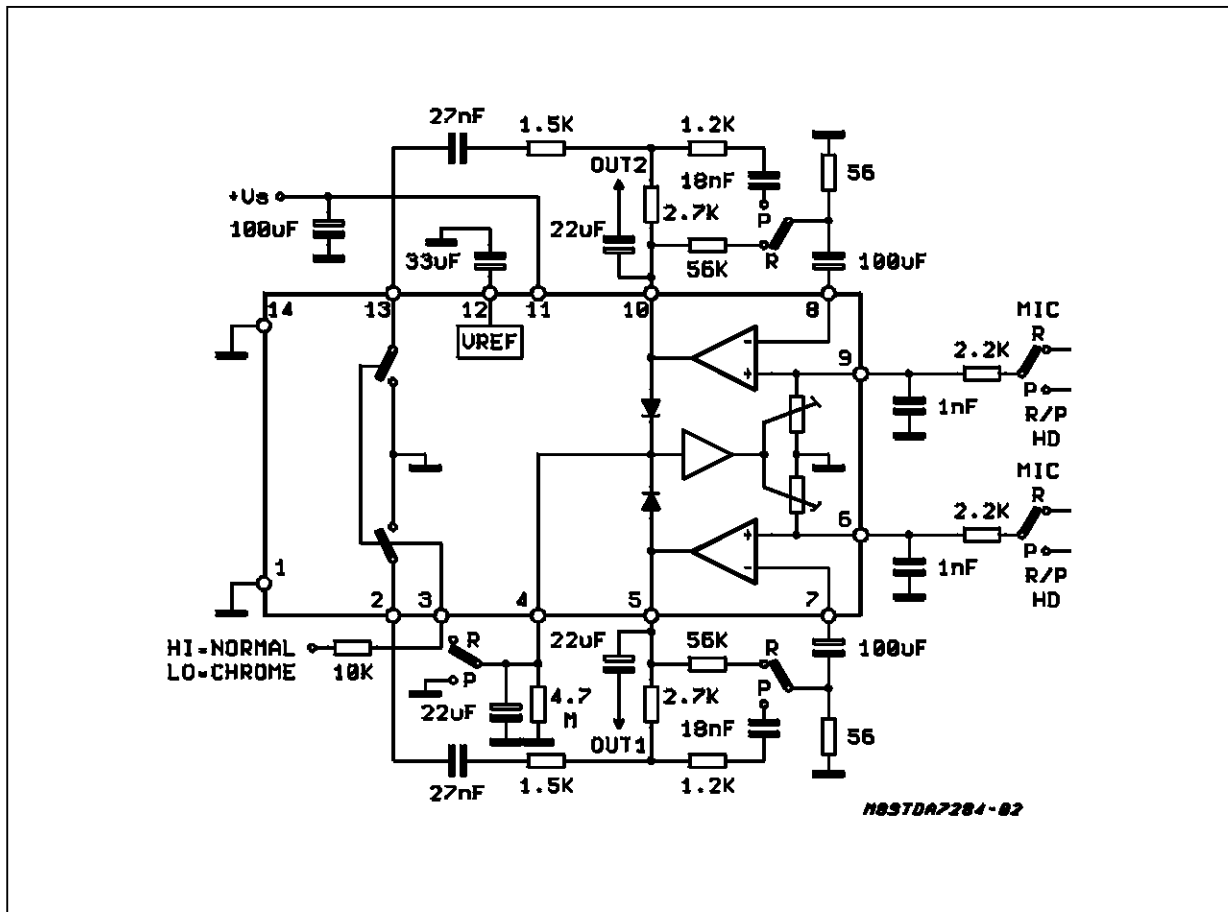
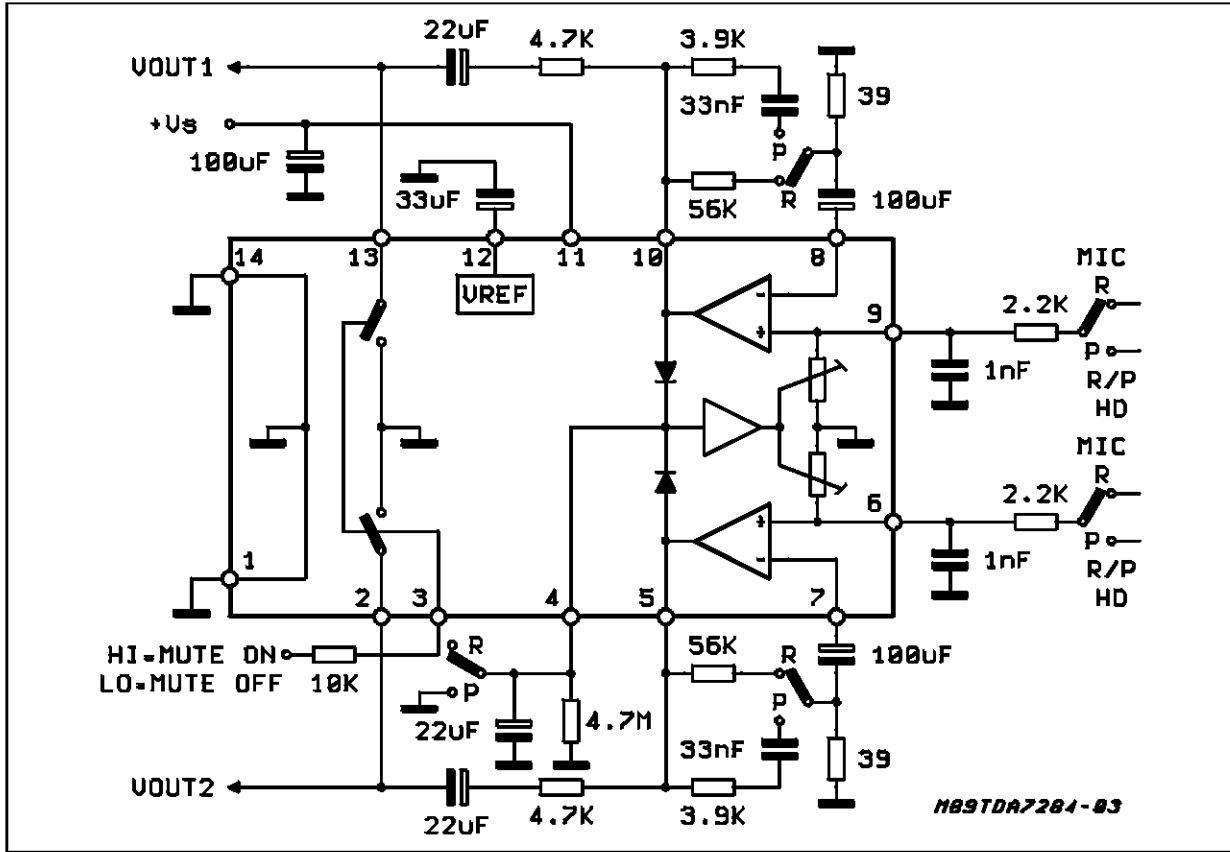

Figure 22: Application Circuit with Output Muting



**SVR**

A reference circuit is enclosed to provide a stable voltage and to supply a stable current to all cur-

rent mirrors.

SVR capacitor is also connected to this block for good ripple rejection.

# TDA7284

## DIP14 PACKAGE MECHANICAL DATA

| DIM. | mm   |       |      | inch  |       |       |
|------|------|-------|------|-------|-------|-------|
|      | MIN. | TYP.  | MAX. | MIN.  | TYP.  | MAX.  |
| a1   | 0.51 |       |      | 0.020 |       |       |
| B    | 1.39 |       | 1.65 | 0.055 |       | 0.065 |
| b    |      | 0.5   |      |       | 0.020 |       |
| b1   |      | 0.25  |      |       | 0.010 |       |
| D    |      |       | 20   |       |       | 0.787 |
| E    |      | 8.5   |      |       | 0.335 |       |
| e    |      | 2.54  |      |       | 0.100 |       |
| e3   |      | 15.24 |      |       | 0.600 |       |
| F    |      |       | 7.1  |       |       | 0.280 |
| I    |      |       | 5.1  |       |       | 0.201 |
| L    |      | 3.3   |      |       | 0.130 |       |
| Z    | 1.27 |       | 2.54 | 0.050 |       | 0.100 |

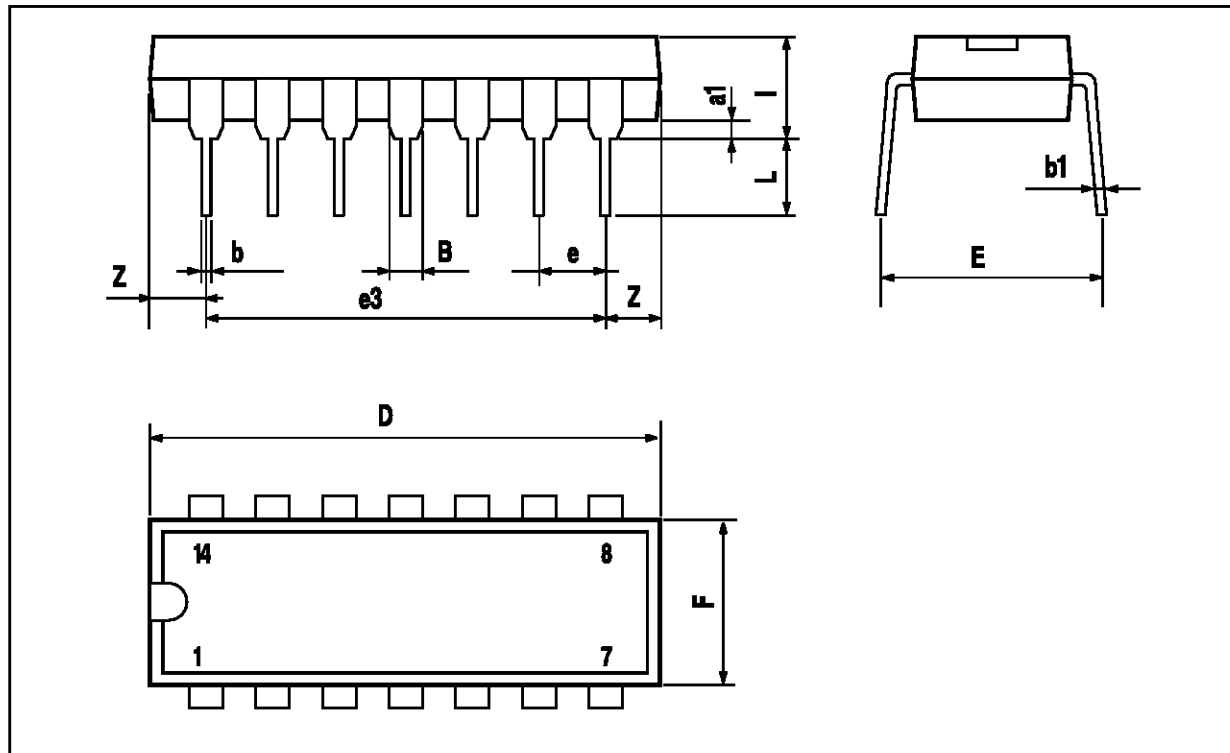

## SO14 PACKAGE MECHANICAL DATA

| DIM. | mm         |      |      | inch  |       |       |
|------|------------|------|------|-------|-------|-------|
|      | MIN.       | TYP. | MAX. | MIN.  | TYP.  | MAX.  |
| A    |            |      | 1.75 |       |       | 0.069 |
| a1   | 0.1        |      | 0.2  | 0.004 |       | 0.008 |
| a2   |            |      | 1.6  |       |       | 0.063 |
| b    | 0.35       |      | 0.46 | 0.014 |       | 0.018 |
| b1   | 0.19       |      | 0.25 | 0.007 |       | 0.010 |
| C    |            | 0.5  |      |       | 0.020 |       |
| c1   | 45° (typ.) |      |      |       |       |       |
| D    | 8.55       |      | 8.75 | 0.336 |       | 0.344 |
| E    | 5.8        |      | 6.2  | 0.228 |       | 0.244 |
| e    |            | 1.27 |      |       | 0.050 |       |
| e3   |            | 7.62 |      |       | 0.300 |       |
| F    | 3.8        |      | 4.0  | 0.15  |       | 0.157 |
| L    | 0.5        |      | 1.27 | 0.020 |       | 0.050 |
| M    |            |      | 0.68 |       |       | 0.027 |
| S    | 8° (max.)  |      |      |       |       |       |

