

**STEREO CASSETTE PLAYER AND  
MOTOR SPEED CONTROLLER**

ADVANCE DATA

- WIDE OPERATING SUPPLY VOLTAGE (1.8V to 6V)
- HIGH OUTPUT POWER (30mW/32Ω/3V)
- LOW DISTORTION DC VOLUME CONTROL
- NO BOUCHEROT CELL
- LOW QUIESCENT CURRENT (15mA)
- NO INPUT CAPACITORS FOR PREAMPLIFIERS
- LOW MOTOR REFERENCE VOLTAGE (200mV)

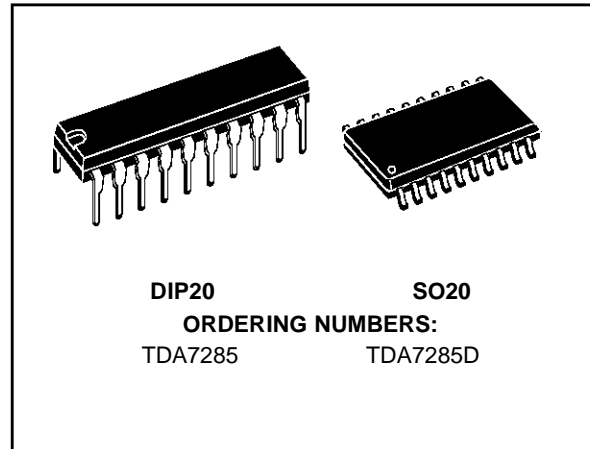

**DESCRIPTION**

The TDA7285 is a monolithic integrated circuit designed for the portable players market and assembled in a plastic DIP20 and SO20. The internal functions are: preamplifier, DC volume control, headphone driver and motor speed controller.

**BLOCK DIAGRAM**

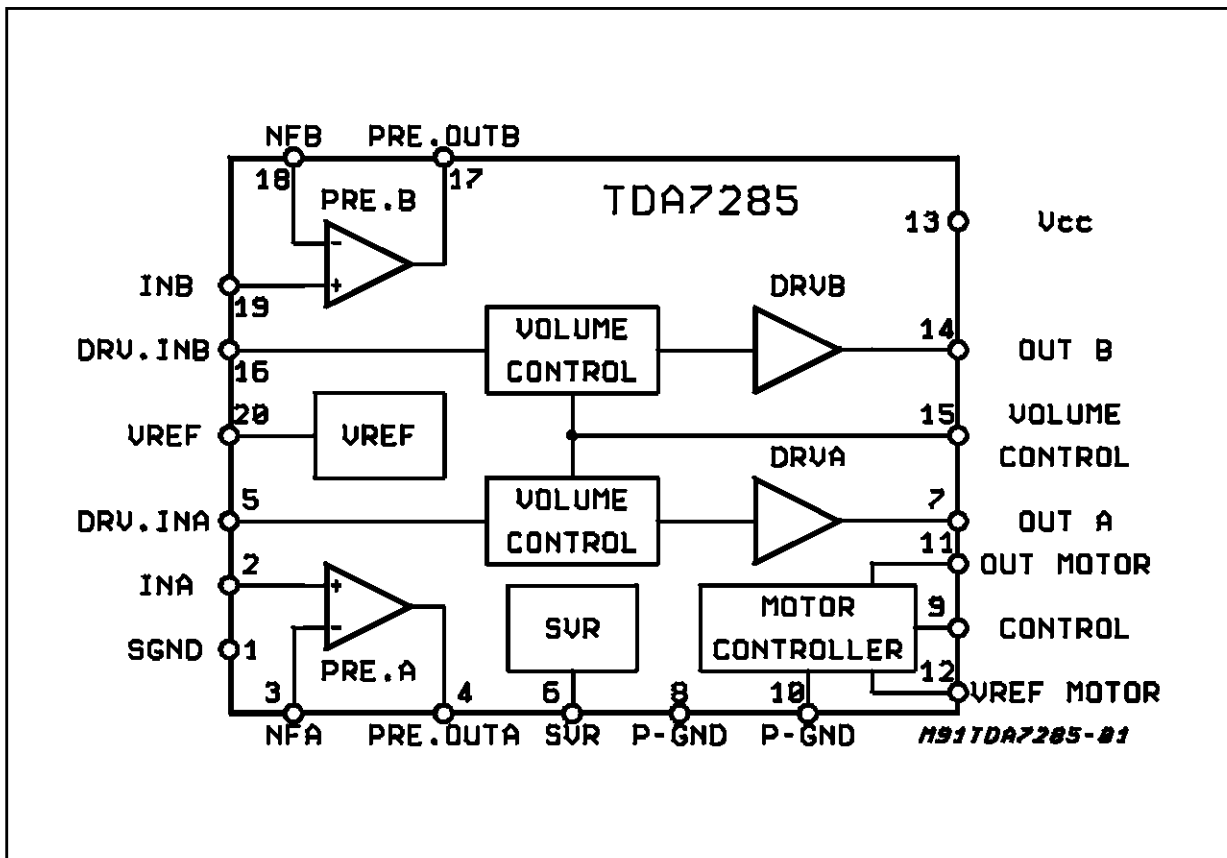

## TDA7285

### PIN CONNECTION (Top view)

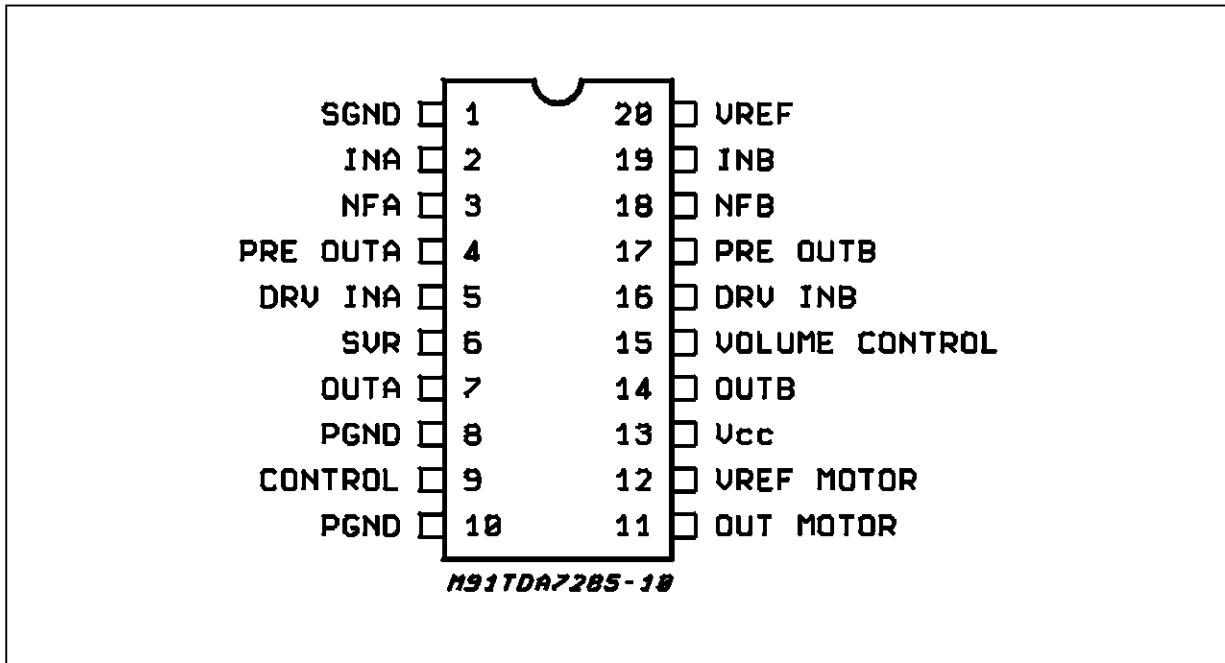

### ABSOLUTE MAXIMUM RATINGS

Symbol	Parameter	Value	Unit
$V_S$	Supply Voltage	8	V
$I_{Omax}$	Maximum Output Current	70	mA
$I_{m\ max}$	Maximum Motor Current	700	mA
$P_{tot}$	Total Power Dissipation $T_{amb} = 90^\circ\text{C}$	0.9	W
$T_{op}$	Operating Temperature	-20 to +70	$^\circ\text{C}$
$T_{stg}, T_j$	Storage and Junction Temperature	-40 to 150	$^\circ\text{C}$

### THERMAL DATA

Symbol	Description	SO20	DIP20	Unit
$R_{th\ j-amb}$	Thermal Resistance Junction-ambient	150	100	$^\circ\text{C/W}$

**DC CHARACTERISTICS** ( $T_{amb} = 25^\circ\text{C}$ ;  $V_S = 3\text{V}$ ;  $R_L = 32\Omega$  (Headphone) and  $R_L = 10\text{K}\Omega$  (Preamplifier);  $V_i = 0$ ; VOL. Control =  $V_{ref}$ ).

Terminal No	1	2	3	4	5	6	7	8	9	10	11	12	13	14	15	16	17	18	19	20
Term. Volt. (V)	0	1.5	1.5	1.5	1.5	2.7	1.4	0	2.8	0	1.6	3	3	1.4	1.5	1.5	1.5	1.5	1.5	1.5

**ELECTRICAL CHARACTERISTICS** ( $V_S = 3V$ ;  $R_L = 32\Omega$ , Vol. Control =  $2/3 V_{ref}$  (pin 20);  $T_{amb} = 25^\circ C$ ;  $f = 1KHz$ ; unless otherwise specified)

Symbol	Parameter	Test Condition	Min.	Typ.	Max.	Unit
$V_S$	Supply Range		1.8		6	V
$I_d$	Total Quiescent Drain Current			15	22	mA

#### PLAYBACK AMPLIFIER

$G_{vo}$	Open Loop Gain			70		dB
$G_v$	Close Loop Gain			33		dB
$V_O$	Output Voltage	THD = 1%	600	750		mV
THD	Total Harmonic Distortion	$V_O = 330mV_{rms}$		0.05	0.25	%
$I_b$	Bias Current			3		$\mu A$
$C_t$	Cross Talk	$R_S = 2.2K\Omega$ ; $V_O = 330mV_{rms}$		74		dB
$e_n$	Total Input Noise	$R_S = 2.2K\Omega$ ; $B = 22Hz$ to $22KHz$		1.2		$\mu V$
SVR1	Ripple Rejection	$R_S = 2.2K\Omega$ ; $V_r = 100mV_{rms}$ $f = 100Hz$ ; $C_{SVR} = 100\mu F$		50		dB

#### HEADPHONE DRIVER

$V_{DC}$	Output DC Voltage			1.4		V
$P_O$	Output Power	THD = 10%	20	30		mW
$P_{O1}$	Transient Output Power	THD = 10% $R_L = 16\Omega$		50		mW
$G_v$	Close Loop Gain	$P_O = 5mW$		31		dB
	Volume Control range		66	75		dB
THD	Total Harmonic Distortion	$P_O = 5mW$		0.3	1	%
$C_t$	Cross Talk	$P_O = 5mW$ ; $R_S = 10K\Omega$		50		dB
SVR2	Ripple Rejection	$R_S = 600\Omega$ ; $V_r = 100mV$ $f = 100Hz$ ; $C_{SVR} = 100\mu F$		47		dB

#### MOTOR SPEED CONTROL

$V_{ref}$	Motor Reference Voltage (pin 12)		0.18	0.20	0.22	V
K	Shunt Ratio	$I_m = 100mA$	45	50	55	-
$V_{sat}$	Residual Voltage	$I_m = 100mA$		0.13	0.30	V
$\frac{\Delta V_{ref}}{V_{ref}} / \Delta V_S$	Line Regulation	$I_m = 100mA$ ; $V_S = 1.8$ to $6V$		0.20	0.8	%/V
$\frac{\Delta K}{K} / \Delta V_S$	Voltage Characteristics of Shunt Ratio	$I_m = 100mA$ ; $V_S = 1.8$ to $6V$		0.80	3	%/V
$\frac{\Delta V_{ref}}{V_{ref}} / \Delta I_m$	Load Regulation	$I_m = 30$ to $200mA$		0.015	0.08	%/mA
$\frac{\Delta K}{K} / \Delta I_m$	Current Characteristics of Shunt Ratio	$I_m = 30$ to $200mA$		0.03	0.1	%/mA
$\frac{\Delta V_{ref}}{V_{ref}} / \Delta T_{amb}$	Temperature Characteristics of Reference Voltage	$I_m = 100mA$ $T_{amb} = -20$ to $+60^\circ C$		0.04		%/°C
$\frac{\Delta K}{K} / \Delta T_{amb}$	Temperature Characteristics of Shunt Ratio	$I_m = 100mA$ $T_{amb} = -20$ to $+60^\circ C$		0.02		%/°C

# TDA7285

Figure 1: Test and Application Circuit

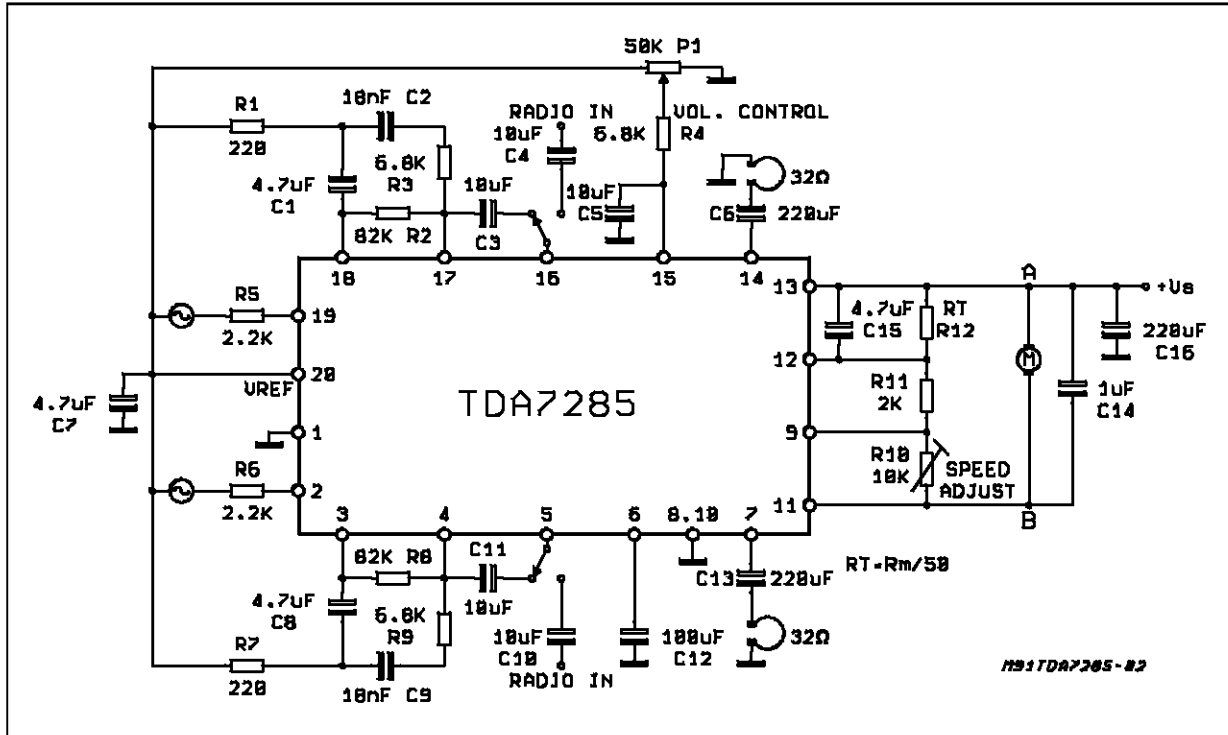
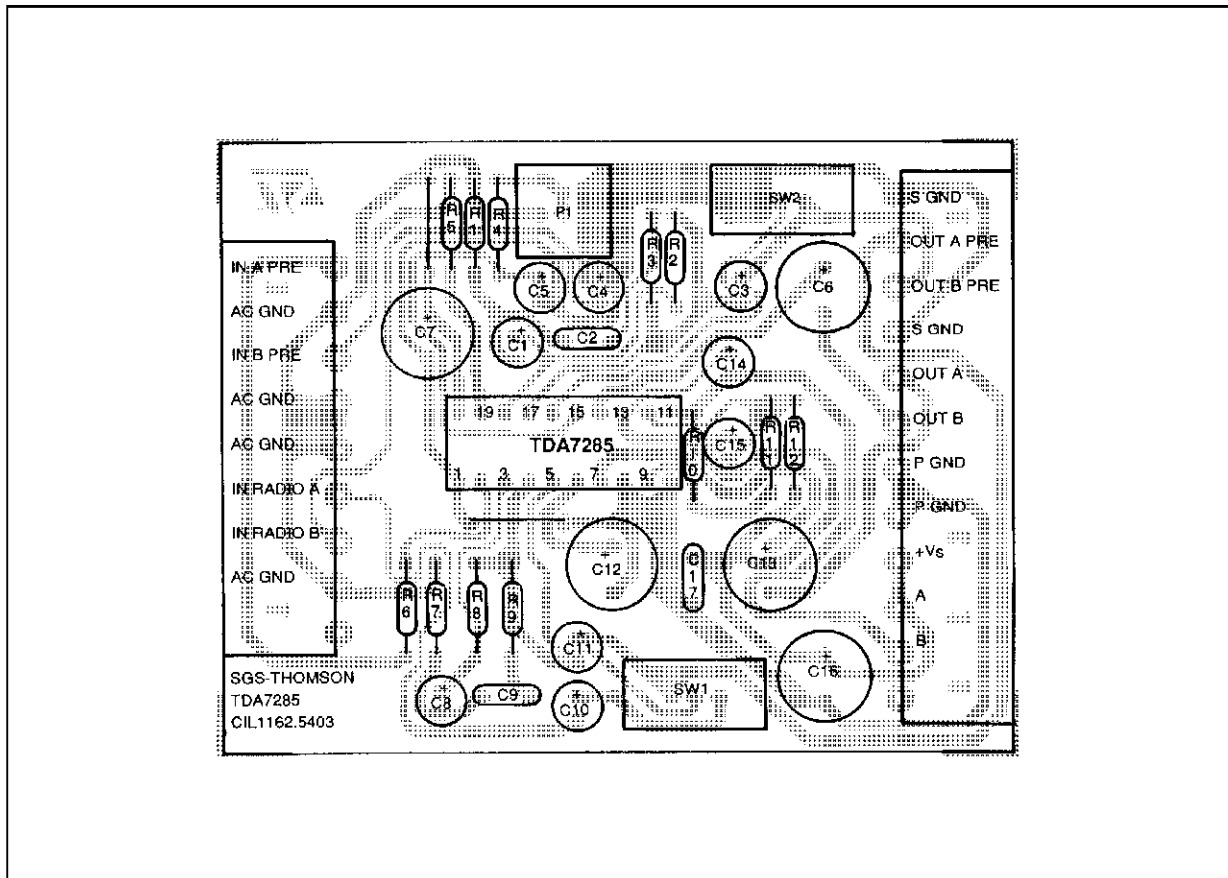
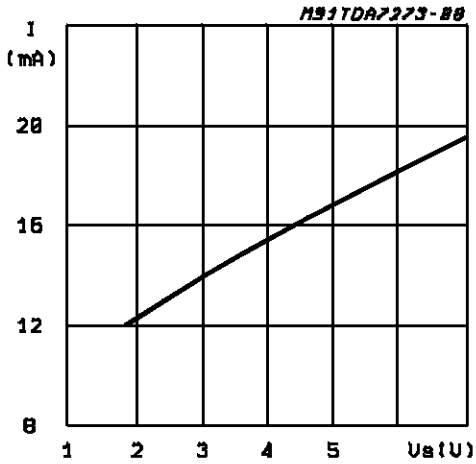

Figure 2: P.C. Board and Component Layout of the Circuit of Figure 2 (1:1 scale)



**Figure 3:** Quiescent Drain Current vs. Supply Voltage



**Figure 4:** Reference voltage  $V_{s/2}$  (pin 20) vs. Supply Voltage

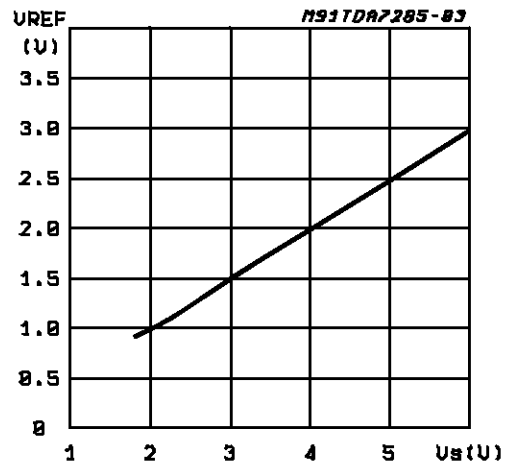

**Figure 5:** Closed Loop Gain vs. Frequency (PREAMPLIFIER)



**Figure 6:** Distortion vs. Frequency (PREAMPLIFIER)

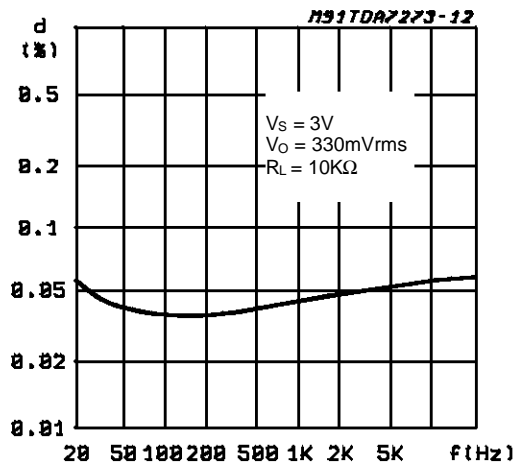

**Figure 7:** Supply Voltage Rejection vs. Frequency (PREAMPLIFIER)

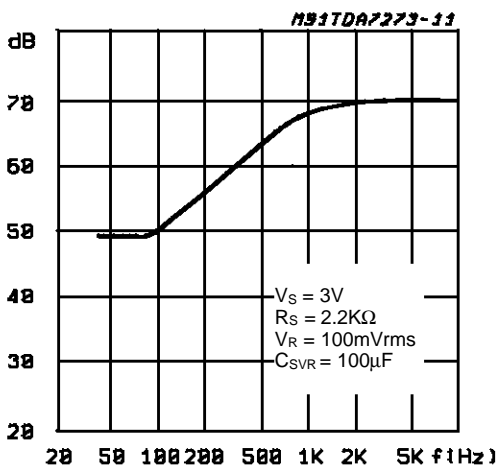

**Figure 8:** Quiescent Output Voltage vs. Supply Voltage (DRIVER)

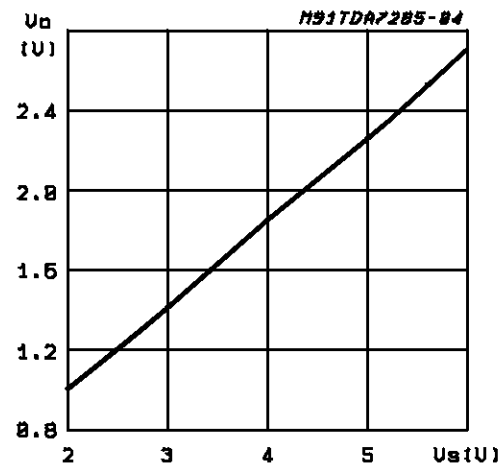

**Figure 9:** Closed Loop Gain vs. Frequency (DRIVER)

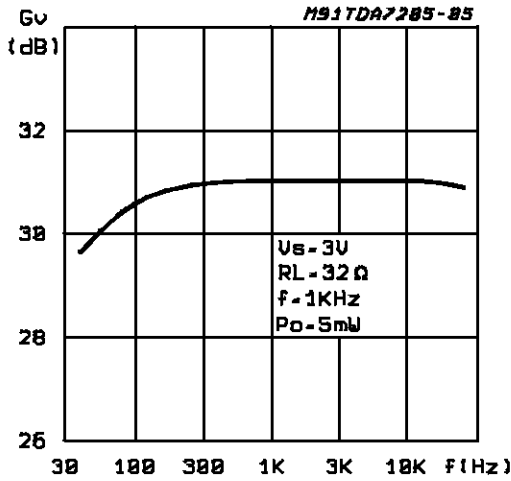

**Figure 10:** Output Power vs. Supply Voltage (DRIVER)

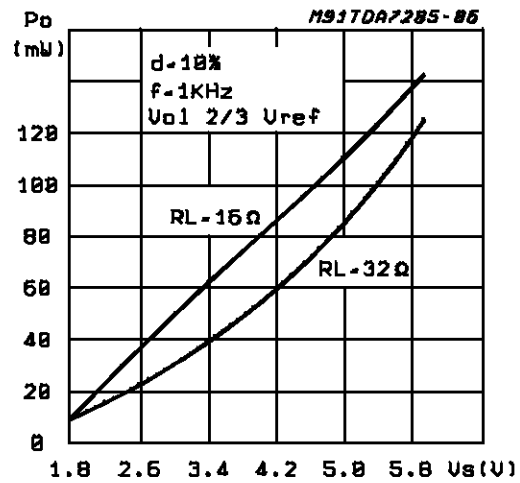

**Figure 11:** Distortion vs. Output Power (DRIVER)

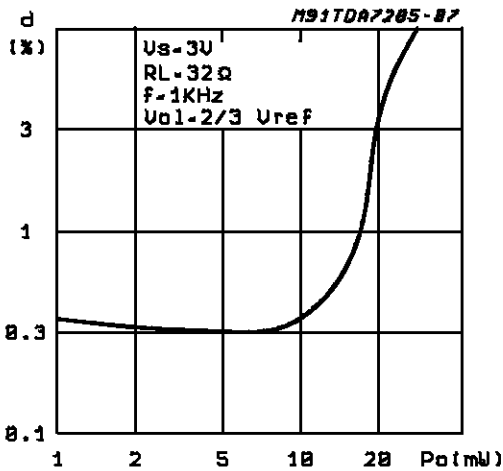

**Figure 12:** Distortion vs. Frequency (DRIVER)

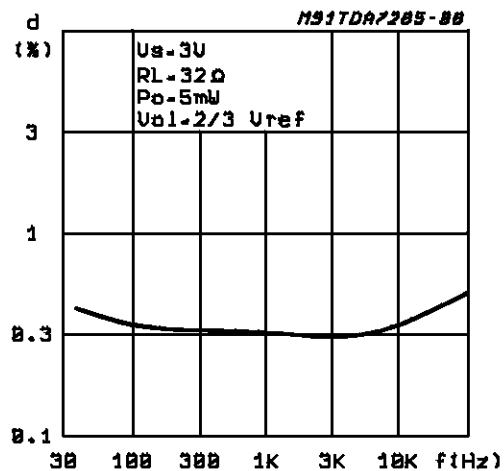

**Figure 13:** Supply Voltage Rejection vs. Frequency (DRIVER)

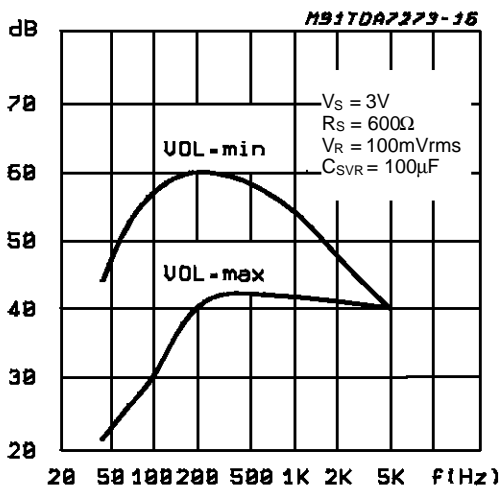

**Figure 14:** Volume Control (0dB = 10mW;  $V_S = 3V$ ;  $R_{VOL} = 50K\Omega$ ;  $R_L = 32\Omega$ ;  $f = 1KHz$ ) (DRIVER)

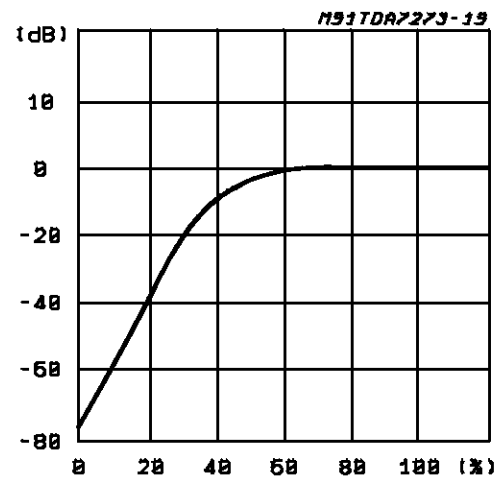

**Figure 15:** Reference Voltage (Pin 12) vs. Supply Voltage (MOTOR)

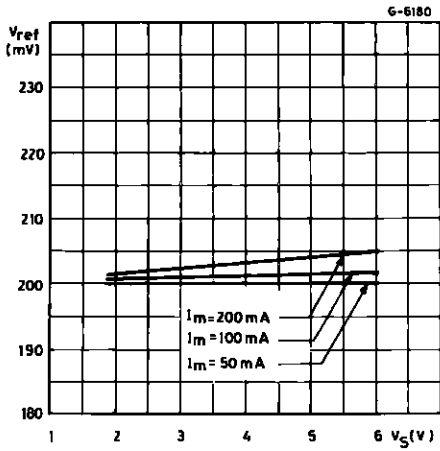

**Figure 16:** Shunt Ratio vs. Supply Voltage (MOTOR)

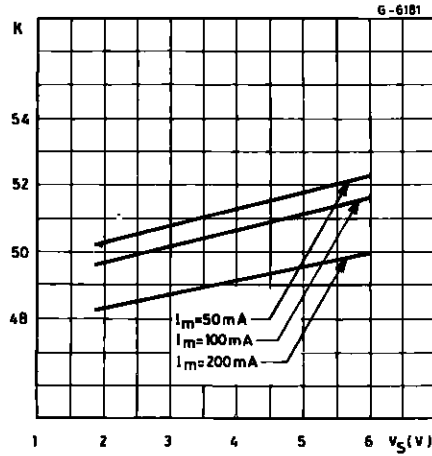

**Figure 17:** Shunt Ratio vs. Load Current (MOTOR)

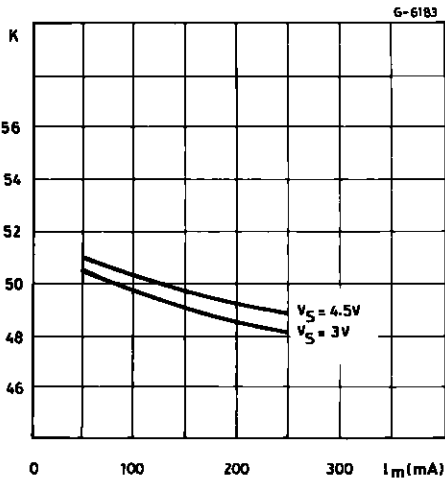

**Figure 18:** Saturation Voltage vs. Load Current (MOTOR)

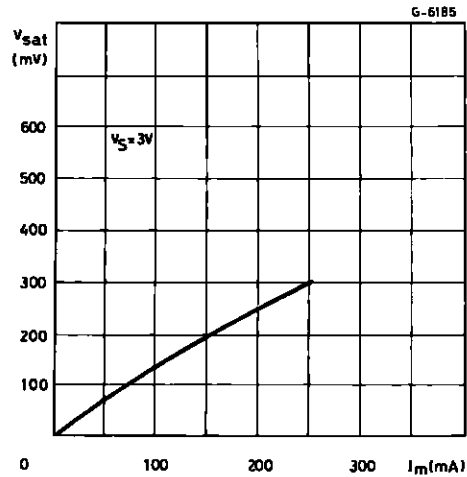

**Figure 19:** Speed Variations vs. Supply Voltage (MOTOR)

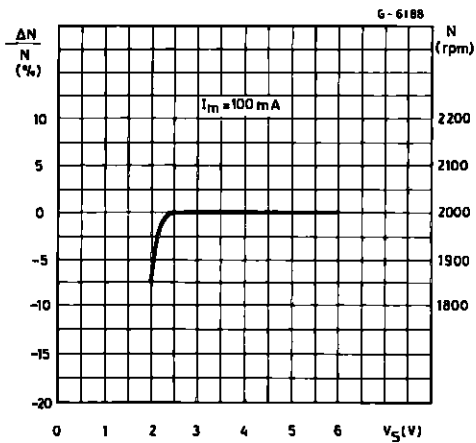

**Figure 20:** Speed Variations vs. Motor Current (MOTOR)

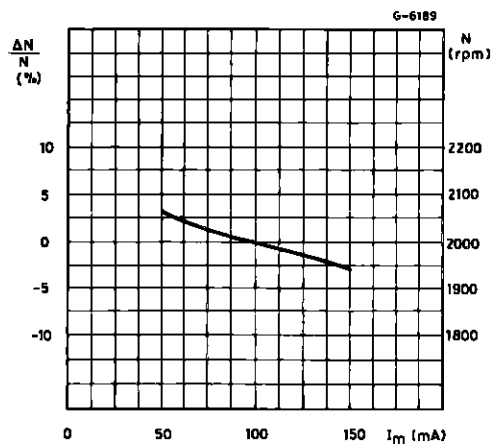





## SO20 PACKAGE MECHANICAL DATA

DIM.	mm			inch		
	MIN.	TYP.	MAX.	MIN.	TYP.	MAX.
A			2.65			0.104
a1	0.1		0.3	0.004		0.012
a2			2.45			0.096
b	0.35		0.49	0.014		0.019
b1	0.23		0.32	0.009		0.013
C		0.5			0.020	
c1	45 (typ.)					
D	12.6		13.0	0.496		0.512
E	10		10.65	0.394		0.419
e		1.27			0.050	
e3		11.43			0.450	
F	7.4		7.6	0.291		0.299
L	0.5		1.27	0.020		0.050
M			0.75			0.030
S	8 (max.)					

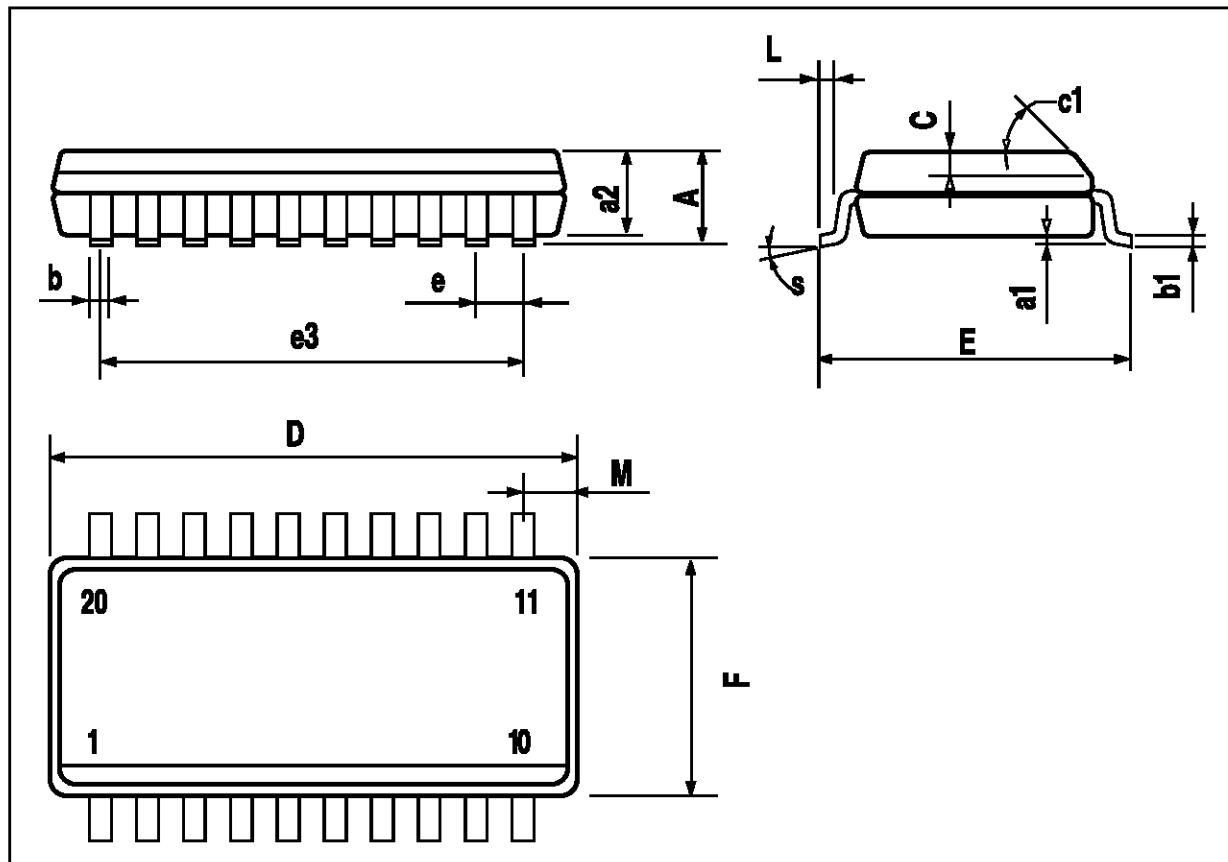

# TDA7285

## DIP20 PACKAGE MECHANICAL DATA

DIM.	mm			inch		
	MIN.	TYP.	MAX.	MIN.	TYP.	MAX.
a1	0.254			0.010		
B	1.39		1.65	0.055		0.065
b		0.45			0.018	
b1		0.25			0.010	
D			25.4			1.000
E		8.5			0.335	
e		2.54			0.100	
e3		22.86			0.900	
F			7.1			0.280
I			3.93			0.155
L		3.3			0.130	
Z			1.34			0.053

