

DATA SHEET



TDA1380 DCC read amplifier (READ 3)

Preliminary specification
File under Integrated Circuits, IC01

September 1994

Philips Semiconductors



PHILIPS

DCC read amplifier (READ 3)

TDA1380

FEATURES

- Single 3 V supply
- Low power consumption
- Differential inputs for low power head configuration
- Can be used with 1st, 2nd and 3rd generation digital signal processing ICs
- Automatic gain control for DCC preamplifiers
- Selectable input amplifiers for A or B side of cassette
- ACC playback via DCC preamplifiers
- Uncommitted amplifiers for equalization during ACC playback
- Low noise current sources for the sense currents of the DCC heads
- Generates reference sense current for temperature compensation of the write current, in recordable application with the TDA1381
- High feedback application possible (for adjustment minimization)
- Suitable for digital post-processor.



GENERAL DESCRIPTION

The TDA1380 amplifies, filters and multiplexes signals that are input from an 18-channel magnetoresistive thin film head (MRH) suitable for the DCC (Digital Compact Cassette) and ACC (Analog Compact Cassette) systems. The device also contains current sources to provide sense currents through the heads and amplifiers for magnetic feedback and biasing. Two uncommitted amplifiers are available for analog equalization.

ORDERING INFORMATION

TYPE NUMBER	PACKAGE		
	NAME	DESCRIPTION	VERSION
TDA1380	TQFP64 ⁽¹⁾	plastic thin quad flat package; 64 leads; body 10 × 10 × 1.4 mm	SOT314-2

Note

1. When using IR reflow soldering it is recommended that the Drypack instructions in the "Quality Reference Handbook": (order number 9398 510 63011) are followed.

DCC read amplifier (READ 3)

TDA1380

QUICK REFERENCE DATA

SYMBOL	PARAMETER	CONDITIONS ON PINS ⁽¹⁾			MIN.	TYP.	MAX.	UNIT
		CS	SA	AB				
V_{DD}	supply voltage	–	–	–	2.7	3.0	5.5	V
V_{CCM}	supply voltage feedback amplifiers	–	–	–	2.7	3.0	5.5	V
$I_{DDCC} + I_{CCM}$	supply current DCC mode	1	0	X	28	39	53	mA
$I_{DDACC} + I_{CCM}$	supply current ACC mode	1	1	X	26	35	47	mA
I_{DDRS}	supply current reference sense current mode	0	0	X	0.6	1.2	1.6	mA
I_{DDAB}	supply current sense AB mode	0	1	1	1.5	2.7	3.7	mA
$I_{DDstb} + I_{CCM}$	supply current standby mode	0	1	0	–	0.2	0.3	mA
$P_{(tot)DCC}$	total power dissipation DCC mode; note 2	1	0	X	–	120	–	mW
$P_{(tot)ACC}$	total power dissipation ACC mode; note 2	1	1	X	–	105	–	mW
T_{amb}	operating ambient temperature	–	–	–	–30	–	+85	°C

Notes

1. In the conditions column 0 = LOW; 1 = HIGH; X = don't care.
2. $V_{DD} = V_{CCM} = 3\text{ V}$; $I_{DSEN} = 0$; $I_{FB} = 0$.

DCC read amplifier (READ 3)

TDA1380

PINNING

SYMBOL	PIN	DESCRIPTION
DSENADJ1	1	adjustment pin for sense current 1 (A and B)
DSENADJ2	2	adjustment pin for sense current 2 (A and B)
DSENADJ3	3	adjustment pin for sense current 3 (A and B)
V _{ref} SENA	4	reference voltage output sense (A)
V _{ref} SENB	5	reference voltage output sense (B)
DSEN1B	6	sense current output 1 (B)
DSEN2B	7	sense current output 2 (B)
DSEN3B	8	sense current output 3 (B)
DSEN3A	9	sense current output 3 (A)
DSEN2A	10	sense current output 2 (A)
DSEN1A	11	sense current output 1 (A)
INX0B	12	auxiliary channel input/channel 0 input (B)
IN01B	13	channel 0 and 1 input (B)
IN1B	14	channel 1 input (B)
INX25B	15	channels AUX, 2 and 5 input (B)
IN23B	16	channels 2 and 3 input (B)
IN34B	17	channels 3 and 4 input (B)
IN4B	18	channel 4 input (B)
IN56B	19	channels 5 and 6 input (B)
IN67B	20	channels 6 and 7 input (B)
IN7B	21	channel 7 input (B)
IN7A	22	channel 7 input (A)
IN67A	23	channels 6 and 7 input (A)
IN56A	24	channels 5 and 6 input (A)
IN4A	25	channel 4 input (A)
IN34A	26	channels 3 and 4 input (A)
IN23A	27	channels 2 and 3 input (A)
INX25A	28	channels AUX, 2 and 5 input (A)
IN1A	29	channel 1 input (A)
IN01A	30	channels 0 and 1 input (A)
INX0A	31	auxiliary channel input/channel 0 input (A)
V10	32	reference voltage for DCC inputs
MFR2B	33	right channel feedback amplifier output 2 (B)
MFR1AB	34	right channel feedback amplifier output 1 (A and B)

SYMBOL	PIN	DESCRIPTION
MFR2A	35	right channel feedback amplifier output 2 (A)
INMFR	36	right channel feedback amplifier input
OUTRA	37	right channel ACC output (A)
OUTRB	38	right channel ACC output (B)
INEQR	39	right channel equalization amplifier input
OUTEQR	40	right channel equalization amplifier output
V _{CCM}	41	supply voltage for feedback amplifiers
V _{EEM}	42	ground for feedback amplifiers
OUTEQL	43	left channel equalization amplifier output
INEQL	44	left channel equalization amplifier input
OUTLB	45	left channel ACC output (B)
OUTLA	46	left channel ACC output (A)
INMFL	47	left channel feedback amplifier input
MFL2A	48	left channel feedback amplifier output 2 (A)
MFL1AB	49	left channel feedback amplifier output 1 (A and B)
MFL2B	50	left channel feedback amplifier output 2 (B)
V _{ref}	51	reference voltage output
V _{ref} ADC	52	ADC reference voltage output
AB	53	tape sector A or B selection input
RDSYNC	54	read sync pulse input
RDCLK	55	read clock pulse input
SA	56	select ACC mode input
V _{SS}	57	ground
V _{DD}	58	supply voltage
CS	59	chip select input
AGC	60	AGC time constant
VBIAS	61	preamplifier gain control voltage input
RDMUX	62	output of sampled and multiplexed auxiliary and main data signals
OUTX	63	auxiliary channel preamplifier output
MUXINX	64	auxiliary channel multiplexer input

DCC read amplifier (READ 3)

TDA1380

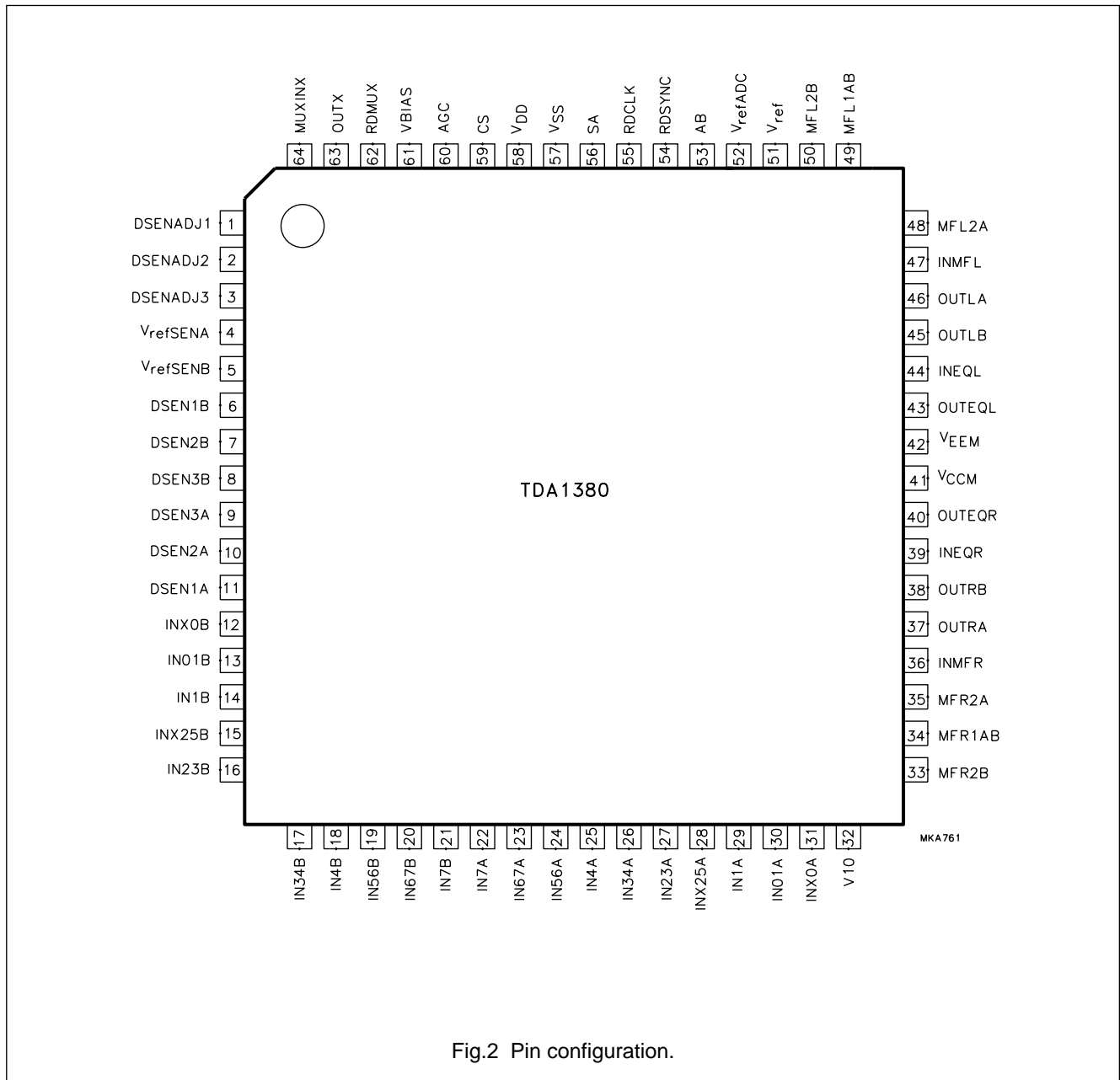

Fig.2 Pin configuration.

DCC read amplifier (READ 3)

TDA1380

FUNCTIONAL DESCRIPTION

DCC data amplifiers and filters

The TDA1380 has 18 low-noise preamplifiers, which are connected to an 18-channel MRH. For each tape sector the MRH is partitioned into three strings of three heads (see Fig.11). Depending on the tape sector selection signal AB, nine preamplifiers for the A-sector, or nine preamplifiers for the B-sector of the tape are selected. Eight of the nine channels are for the DCC main data, and one for the auxiliary (AUX) data. The eight main data channels have pre-equalization for frequencies from 1 kHz up to 50 kHz (1st order highpass, -3 dB at 75 kHz), and lowpass filtering for anti-aliasing (2nd order active, -3 dB at 120 kHz). The AUX channel has a flat frequency response. The AUX data is continuously available at output OUTX. This output must be AC-coupled to the multiplexer input MUXINX. All inputs must be AC-coupled to the MRH. The inputs are internally biased at pin V10. The voltage at pin V10 is temperature dependent and is not intended for external use. Pin V10 has to be decoupled to the positive supply voltage (V_{DD}).

Automatic gain control

The DCC part is equipped with an AGC circuit which decreases the gain of the preamplifiers when the level at RDMUX exceeds a preset value. In this way an optimum

voltage swing at the RDMUX output is obtained (for the ADC input of SAA2051, SAA2032, SAA2023 or SAA3323). The response time of the AGC can be set by an external capacitor connected to pin 60. There is a fixed relationship between the source and sink current at this pin, resulting in a fixed relationship between the decay time and the recover time of the preamplifier gain. The AGC is active only in the DCC mode and can be switched off by connecting pin 60 to V_{SS} .

Multiplexer

A multiplexing circuit switches the nine digital channels sequentially to the output. The AUX data is sampled during two clock periods, the eight main data channels are sampled during one clock period. The effective sample frequency is one tenth of the clock frequency at RDCLK. A timing overview is illustrated in Fig.4.

Analog amplifiers

For ACC playback the TDA1380 employs four DCC preamplifiers (per tape sector) for amplification of the left and right analog signals. Amplifiers CHX and CH0 are used for the left channel and CH4 and CH5 for the right channel. The buffered left and right channel outputs are available at four pins (see Table 1). Pins that carry no left and right channel signals will have a DC level V_A .

Table 1 ACC playback.

AB	TAPE SELECT	OUTLA	OUTLB	OUTRA	OUTRB	REMARKS
1	A	left	V_A	right	V_A	allows separate amplitude adjustment for sectors A and B
0	B	V_A	left	V_A	right	
1	A	left	note 1	right	note 1	allows one amplitude setting only for sectors A and B (DSP operation; high feedback operation)
0	B	left	note 1	right	note 1	

Note

- At least one of OUTLB and OUTRB are externally connected to V_{DD} .

DCC read amplifier (READ 3)

TDA1380

Feedback amplifiers

Two feedback amplifiers are available for driving a conductor in the MRH, thus providing magnetic feedback to improve the linearity of the analog audio response. In both the ACC and DCC mode, the feedback amplifiers are used for DC biasing of the MRH. The circuit principle of the feedback amplifiers is illustrated in Fig.9.

Equalization amplifiers

Two uncommitted operational amplifiers are available for pre-equalization of the left and right ACC outputs. These amplifiers are only operational during ACC playback. The non-inverting input is internally connected to a DC voltage which is approximately equal to V_{ref} . If the amplifiers are not used in the application, it is advised to connect the outputs to the inputs.

Current and voltage sources

Separate, adjustable low-noise current sources are available to provide the sense currents to the MRHs. The active current outputs are controlled by the mode switch (see Table 2). In the reference sense current mode, only one source is active (DSEN1B, pin 6). This current can be used for temperature measurement of the DCC head, thereby enabling control of the write current (TDA1381) when recording. The principle of the sense current sources is illustrated in Fig.8. The typical value of the output current is determined by resistors connected between the adjust pins and V_{SS} ; where $I_{DSEN} = 0.33/R_{ADJUST}$.

The DC output voltages V_{ADC} , V_{ref} , V_{10} , $V_{refSENA}$ and $V_{refSENB}$ are derived from an internal bandgap reference voltage source. The voltage V_{refADC} (referenced to V_{SS}) can be used as a reference voltage for analog-to-digital conversion of the RDMUX output.

Table 2 Sense current sources.

MODE	DIGITAL INPUTS ⁽¹⁾			AVAILABLE SENSE CURRENT	ACTIVE DC OUTPUTS
	CS	SA	AB		
Standby	0	1	0	–	–
Reference sense current	0	0	X	DSEN1B	–
Sense AB	0	1	1	DSEN1A; DSEN2A; DSEN3A DSEN1B; DSEN2B; DSEN3B	$V_{refSENA}$ $V_{refSENB}$
ACC playback A	1	1	1	DSEN1A; DSEN2A; DSEN3A	$V_{refSENA}$
ACC playback B	1	1	0	DSEN1B; DSEN2B; DSEN3B	$V_{refSENB}$
DCC playback A	1	0	1	DSEN1A; DSEN2A; DSEN3A	$V_{refSENA}$
DCC playback B	1	0	0	DSEN1B; DSEN2B; DSEN3B	$V_{refSENB}$

Note

1. Where X = don't care; 0 = LOW; 1 = HIGH.

DCC read amplifier (READ 3)

TDA1380

Modes of operation

The amplifiers and sense current sources for the ACC and DCC parts can be switched ON/OFF separately by the mode switch signals CS, SA and AB. Also, a connection between OUTLB or OUTRB or both to V_{DD} is recognized as a single output ACC mode where the left and right outputs are present at OUTLA and OUTRA only.

Table 3 Modes of operation.

MODE	DIGITAL INPUT ⁽¹⁾			ACTIVE PARTS (see Fig.1)	ACTIVE DC REFERENCE OUTPUTS
	CS	SA	AB		
Standby	0	1	0		
Reference sense current	0	0	X	reference sense current source	V_{ref}
Sense AB	0	1	1	sense current sources	V_{ref}
ACC playback A/B	1	1	1 or 0	sense currents, data preamplifiers, AN, EQ and FB	V_{ref} ; V10
ACC playback A/B via OUTLA and OUTRA only (note 2)	1	1	1 or 0	sense currents, data preamplifiers, AN, EQ and FB	V_{ref} ; V10
DCC playback A/B	1	0	1 or 0	sense currents, data amplifiers and filters, multiplexer, AGC and FB	V_{ref} ; V10; V_{refADC}
Test mode (note 3)	1	0	1 or 0	sense currents, data amplifiers and filters, multiplexer, AGC and FB	V_{ref} ; V10; V_{refADC}

Notes

1. Where X = don't care; 0 = LOW; 1 = HIGH.
2. At least one of OUTLB or OUTRB are externally connected to V_{DD} .
3. INEQL or INEQR connected to V_{DD} (no user function).

DCC read amplifier (READ 3)

TDA1380

LIMITING VALUESIn accordance with the Absolute Maximum Rating System (IEC 134); voltages referenced to V_{SS} and V_{EEM} .

SYMBOL	PARAMETER	CONDITIONS	MIN.	MAX.	UNIT
V_{DD}	supply voltage	$V_{SS} = V_{EEM} = 0\text{ V}$	-0.3	5.5	V
V_{CCM}	supply voltage feedback amplifiers	$V_{SS} = V_{EEM} = 0\text{ V}$	-0.3	5.5	V
$V_{SS}-V_{EEM}$	difference in ground potential between pins 57 and 42		0	0	V
V_I	voltage input on any pin	$V_{DD} + 0.3 < 5.5\text{ V}$	-0.3	$V_{DD} + 0.3$	V
$I_{I(max)}$	maximum supply current (pins 41, 42, 57 and 58)		-	± 120	mA
I_{FBmax}	maximum current for feedback amplifiers (pins 33 to 35 and 48 to 50)		-	± 80	mA
$I_{sense(max)}$	maximum current on sense current source (pins 1 to 3 and 6 to 11)		-	± 30	mA
$I_{n(max)}$	maximum current on any other pin		-	± 10	mA
P_{tot}	total power dissipation		-	650	mW
T_{amb}	operating ambient temperature		-30	+85	°C
T_{stg}	storage temperature		-65	+50	°C
V_{es}	electrostatic handling		-3000	+3000	V

ELECTROSTATIC HANDLINGEquivalent to discharging a 100 pF capacitor through a 1.5 k Ω series resistor.**THERMAL CHARACTERISTICS**

SYMBOL	PARAMETER	VALUE	UNIT
$R_{th\ j-a}$	thermal resistance from junction to ambient in free air	60	K/W

DCC read amplifier (READ 3)

TDA1380

CHARACTERISTICS $V_{DD} = V_{CCM} = 3\text{ V}$; $V_{SS} = V_{EEM} = 0\text{ V}$; $T_{amb} = 25\text{ }^{\circ}\text{C}$; $f_{clk} = 3.072\text{ MHz}$; unless otherwise specified.

SYMBOL	PARAMETER	CONDITIONS	MIN.	TYP.	MAX.	UNIT
Supply						
V_{DD}	supply voltage		2.7	3.0	5.5	V
V_{CCM}	supply voltage feedback amplifiers		2.7	3.0	5.5	V
I_{DDCC}	supply current DCC mode	CS = 1; SA = 0	18	27	37	mA
I_{DDACC}	supply current ACC mode	CS = 1; SA = 1	16	23	30	mA
I_{DDRS}	supply current reference sense current mode	CS = 0; SA = 0	0.6	1.2	1.6	mA
I_{DDAB}	supply current sense AB mode	CS = 0; SA = 1; AB = 1	1.5	2.7	3.7	mA
I_{CCM}	supply current feedback amplifiers	CS = 1	7.5	12	17.5	mA
$I_{DDstb} + I_{CCM}$	supply current standby mode	CS = 0; AB = 0; SA = 1	–	0.2	0.3	mA
V_{refADC}	reference voltage for ADC	CS = 1; SA = 0; $R_L = 1\text{ k}\Omega$	1.95	2.05	2.15	V
$V_{refSENA}$	sense A reference voltage	CS = 1; AB = 1; $I_O < 5\text{ }\mu\text{A}$; $I_{DSEN} = 10\text{ mA}$	1.0	1.1	1.2	V
$V_{refSENB}$	sense B reference voltage	CS = 1; AB = 0; $I_O < 5\text{ }\mu\text{A}$; $I_{DSEN} = 10\text{ mA}$	1.0	1.1	1.2	V
V_{ref}	reference voltage output	$I_O < 5\text{ }\mu\text{A}$; all modes except standby mode	1.18	1.25	1.32	V
V10	reference voltage for DCC inputs	CS = 1; $I_O < 5\text{ }\mu\text{A}$	0.9	1.0	1.1	V
DCC part						
DATA AMPLIFIERS, CHANNELS 0 TO 7; NOTE 1						
G_{50}	gain at 50 kHz		72	75	78	dB
ΔG_{10}	relative gain at 10 kHz	note 2	–14	–12	–10	dB
G_{100}	gain at 100 kHz		71	76	79	dB
ΔG_{300}	relative gain at 300 kHz	note 2	–22	–12	–3	dB
$V_{n(ref)}$	input referred noise voltage	$f_i = 50\text{ kHz}$; $R_{source} = 70\text{ }\Omega$	–	2.0	–	$\text{nV}/\sqrt{\text{Hz}}$
$\Delta V_{n(ref)}$	3 × standard deviation of input referred noise voltage	$f_i = 50\text{ kHz}$; $R_{source} = 70\text{ }\Omega$	–	0.5	–	$\text{nV}/\sqrt{\text{Hz}}$
THD	total harmonic distortion	$f_i = 10\text{ kHz}$; $V_{62} = 0.35\text{ V (RMS)}$	–	–40	–30	dB
$Z_{i(d)}$	input impedance differential mode		–	7	–	$\text{k}\Omega$

DCC read amplifier (READ 3)

TDA1380

SYMBOL	PARAMETER	CONDITIONS	MIN.	TYP.	MAX.	UNIT
$Z_{i(c)}$	input impedance to V_{SS} common mode		–	7.5	–	$k\Omega$
α_{CS}	channel separation	$f_i = 10$ kHz	30	40	–	dB
SVRR	supply voltage ripple rejection	$f_i = 50$ kHz; note 3	–	–20	–	dB
Auxiliary amplifier, channel X; note 1						
G_{63}	gain at OUTX (pin 63)	100 Hz to 100 kHz	43	46	49	dB
G_{62}	gain at RDMUX (pin 62)	100 Hz to 100 kHz; note 4	56	59	62	dB
$V_{n(ref)}$	input referred noise voltage	$f_i = 50$ kHz; $R_{source} = 70 \Omega$	–	2.0	–	nV/\sqrt{Hz}
$\Delta V_{n(ref)}$	3 x standard deviation input referred noise voltage	$f_i = 50$ kHz; $R_{source} = 70 \Omega$	–	0.5	–	nV/\sqrt{Hz}
$V_{o(rms)}$	maximum output voltage (pin 63) (RMS value)	$f_i = 10$ kHz	0.35	–	–	V
THD	total harmonic distortion	$f_i = 10$ kHz; $V_{63} = 0.35$ V (RMS)	–	–40	–30	dB
SVRR	supply voltage ripple rejection	$f_i = 1$ kHz; note 3	–	–3	–	dB
$R_{L(DC)}$	DC load at pin 63	load connected to V_{SS}	10	–	–	$k\Omega$
$C_{L(AC)}$	AC load at pin 63	load connected to V_{SS}	–	–	100	pF
Output buffer, RDMUX (pin 62)						
$V_{62(rms)}$	maximum output voltage (RMS value)	$R_L = 2$ $k\Omega$	0.35	–	–	V
V_{DC}	DC voltage level at pin 62		0.95	1.15	1.35	V
$\Delta V_{DC(os)}$	DC offset voltage between sampled outputs	note 5	–	–	200	mV
$R_{L(DC)}$	DC load at pin 62	load connected to V_{SS}	1.5	–	–	$k\Omega$
$C_{L(AC)}$	AC load at pin 62	load connected to V_{SS}	–	–	100	pF
t_{set}	settling time of sampled outputs	$C_L = 50$ pF; within 10 mV	–	100	150	ns
$V_{62(M)}$	AGC detector level (peak value)	note 5	320	465	570	mV
AGC_{CR}	AGC control range		9	11	13	dB
I_{source}	AGC source current (pin 60)		16	21	26	μA
I_{sink}	AGC sink current (pin 60)		0.3	0.5	0.8	μA

DCC read amplifier (READ 3)

TDA1380

SYMBOL	PARAMETER	CONDITIONS	MIN.	TYP.	MAX.	UNIT
Select logic inputs (RDCLK and RDSYNC) and mode switch inputs (CS, SA and AB)						
V_{IH}	HIGH level input voltage		$0.7V_{DD}$	–	V_{DD}	V
V_{IL}	LOW level input voltage		0	–	$0.3V_{DD}$	V
I_{IL}	input leakage current		–2	0	+2	μA
C_i	input capacitance	note 7	–	–	10	pF
t_{su}	set-up time for RDSYNC	see Fig.3	35	–	–	ns
t_h	hold time for RDSYNC	see Fig.3	35	–	–	ns
t_r	rise time for RDCLK	see Fig.3Ö	–	–	50	ns
V_{det}	ACC single output mode detection level (pins 38 and 45)		$V_{DD} - 0.45$	$V_{DD} - 0.35$	–	V
Sense current sources						
$I_{DSENmin}$	minimum output current	note 8	–	–	1	mA
$I_{DSENmax}$	maximum output current	note 8	20	–	–	mA
I_{DSEN1B}	reference sense current (pin 6)	note 9	2.7	3.0	3.3	mA
I_{ON}	output current noise	note 10	–	20	–	pA/\sqrt{Hz}
Z_{DSEN}	output impedance	note 10	20	–	–	k Ω
V_{DSEN}	DC voltage level of current outputs (pins 6 to 11)		1.0	–	–	V
ACC part						
ACC AMPLIFIERS						
G_{ACC}	ACC gain	20 Hz to 20 kHz	44	46	48	dB
$V_{n(ref)}$	input referred noise voltage	$f_i = 10 \text{ kHz};$ $R_{source} = 70 \Omega$	–	2.0	–	nV/\sqrt{Hz}
$\Delta V_{n(ref)}$	3 x standard deviation of input referred noise voltage	$f_i = 10 \text{ kHz};$ $R_{source} = 70 \Omega$	–	0.5	–	nV/\sqrt{Hz}
$V_{o(rms)}$	maximum output voltage (RMS value)	$f_i = 1 \text{ kHz}$	0.35	–	–	V
V_A	DC output voltage	see Table 1	0.6	0.9	1.2	V
THD	total harmonic distortion	$f_i = 1 \text{ kHz};$ $V_o = 0.35 \text{ V (RMS)}$	–	–40	–30	dB
SVRR	supply voltage ripple rejection	$f_i = 1 \text{ kHz}$	–	tbf	–	dB
α_{CS}	channel separation	$f_i = 1 \text{ kHz}$	40	–	–	dB
$R_{L(DC)}$	DC load (pins 37, 38 45 and 46)	load connected to V_{SS}	10	–	–	k Ω
$C_{L(AC)}$	AC load (pins 37, 38 45 and 46)	load connected to V_{SS}	–	–	300	pF

DCC read amplifier (READ 3)

TDA1380

SYMBOL	PARAMETER	CONDITIONS	MIN.	TYP.	MAX.	UNIT
Equalization operational amplifiers (EQ); note 11						
$V_{EQ(rms)}$	maximum output voltage (RMS value)	$f_i = 1 \text{ kHz}$	0.35	–	–	V
B_{EQ}	bandwidth	at -3 dB	50	–	–	kHz
THD	total harmonic distortion	$f_i = 1 \text{ kHz};$ $V_O = 0.35 \text{ V (RMS)}$	–	-70	-55	dB
α_{CS}	channel separation	$f_i = 1 \text{ kHz}$	60	–	–	dB
$R_{L(DC)}$	DC load at OUTEQL	load connected to V_{SS}	10	–	–	k Ω
$C_{L(AC)}$	AC load at OUTEQL	load connected to V_{SS}	–	–	300	pF
Feedback amplifiers (FB); note 12						
I_{FBmax}	maximum output current (RMS value)	$f_i = 1 \text{ kHz}$	25	–	–	mA
THD	total harmonic distortion	$f_i = 1 \text{ kHz};$ $I_{FB} = 25 \text{ mA (RMS)}$	–	-60	-50	dB
B_{FB}	bandwidth	at -3 dB	50	–	–	kHz
V_{IFB}	DC voltage level input (pins 36 and 47)		–	1.15	–	V

Notes

- AGC off (maximum gain; pin 60 connected to V_{SS}).
- Gain relative to gain at $f_i = 50 \text{ kHz}$ (see Fig.5).
- Heads connected according to the circuit of Fig.11 (see also Fig.6 for typical supply rejection).
- OUTX AC-coupled to MUXINX via 100 nF capacitor.
- The difference between minimum and maximum DC voltage level at the outputs of the data channels. To be measured at RDMUX.
- Measured with continuous sine wave of 10 kHz at RDMUX, multiplexer in a fixed position. A 1 V (p-p) sine wave corresponds to a multiplexed DCC signal of 1.25 V (p-p).
- Periodically sampled, not tested.
- Pins 6 to 11. The output current is inversely proportional to the value of the resistor connected between the adjust pin DSENADJ1, DSENADJ2, DSENADJ3 and V_{SS} . A resistor of 33 Ω will give 10 mA (typ.) sense current. Other currents can be calculated: $0.33 \text{ V}/R_{ADJUST}$.
- $CS = 0$, $SA = 0$; Resistor of 33 Ω connected between DSENADJ1 and V_{SS} . Typical reference sense current is $100 \text{ mV}/R_{ADJUST}$.
- From 10 to 100 kHz, $I_{DSEN} = 10 \text{ mA}$, a 10 μF capacitor connected between $V_{refSENA}$ and V_{SS} , a 10 μF capacitor connected between $V_{refSENB}$ and V_{SS} .
- Closed loop configuration, unity gain, in accordance with Fig.10.
- Closed loop, unity gain, $R_L = 25 \Omega$, in accordance with Fig.9.

DCC read amplifier (READ 3)

TDA1380

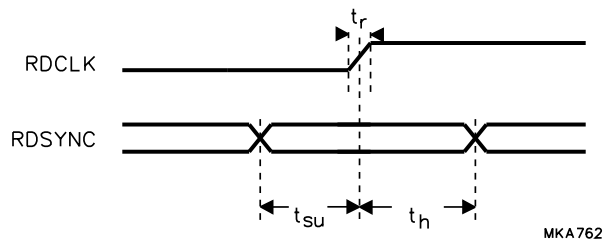

Fig.3 Timing relationship between edges of RDCLK and RDSYNC.

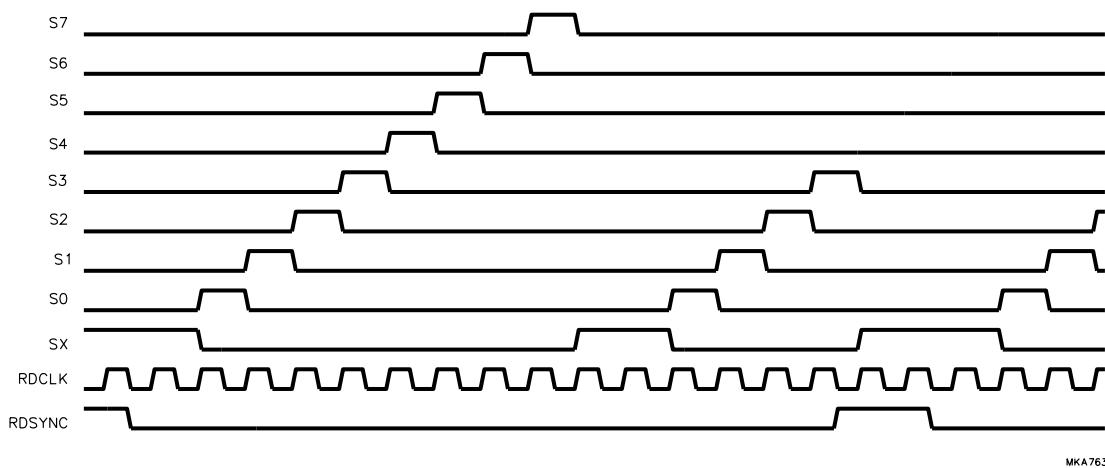

Fig.4 Multiplexer timing diagram.

DCC read amplifier (READ 3)

TDA1380

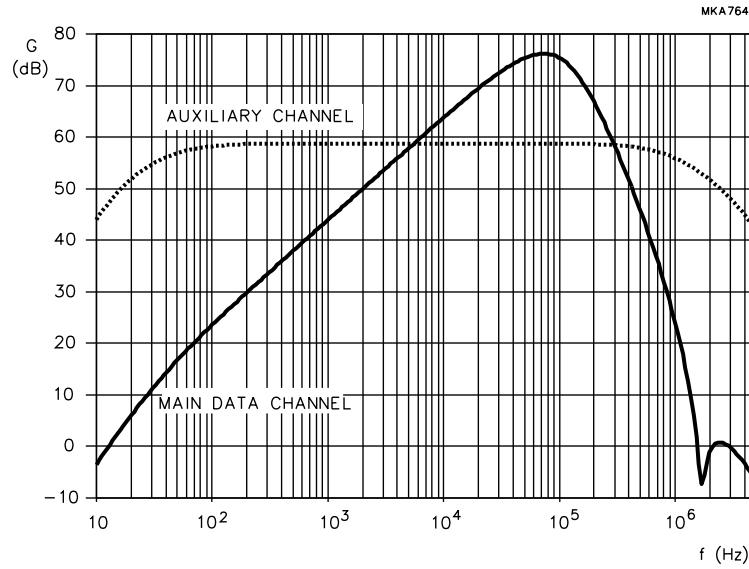

Fig.5 Typical gain of the auxiliary and main data channel (AGC off).

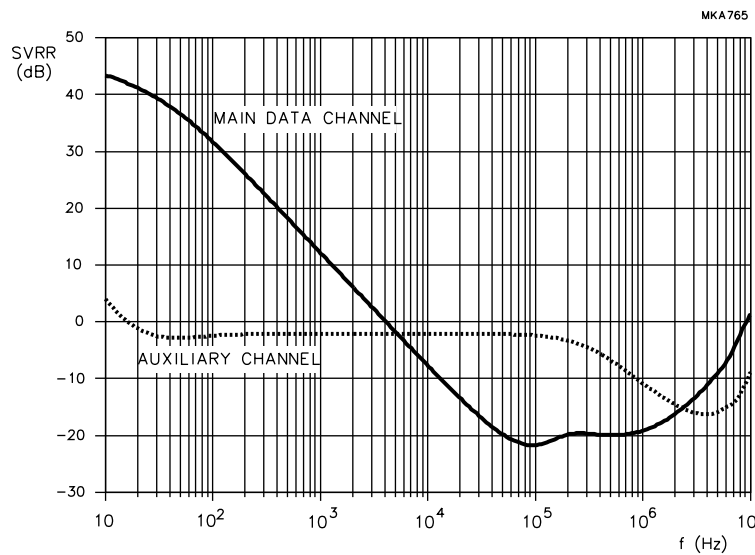

Fig.6 Typical supply rejection of the auxiliary and main data channel (AGC off).

DCC read amplifier (READ 3)

TDA1380

TEST AND APPLICATION INFORMATION

The TDA1380 can be set to the TEST mode by connecting INEQL or INEQR (or both) to V_{DD} . In this mode the switch at pin MUXINX enables monitoring of the input stage and lowpass filter of each data amplifier and also allows input to the highpass filters and following stages. The test multiplexer operates in phase with the output multiplexer. Measurement of the gain of the data channels can be performed in two steps: step 1, gain from the inputs to MUXINX; step 2, gain from MUXINX to RDMUX.

Figure 7 illustrates how to use pin MUXINX in the TEST mode, $C_L < 20$ pF, $R_L > 100$ k Ω , $C_i > 47$ nF and $R_{bias} = 1$ k Ω . The DC voltage, when driving MUXINX, should be 0.7 V higher than the measured DC level of the preamplifier output in order to shut off the emitter follower.

The impedance of the sense current source outputs can be measured from the difference in sense current when applying different voltages to the sense current output. This voltage can vary from 1 V to V_{DD} . Figure 8 illustrates the principle of the sense current sources.

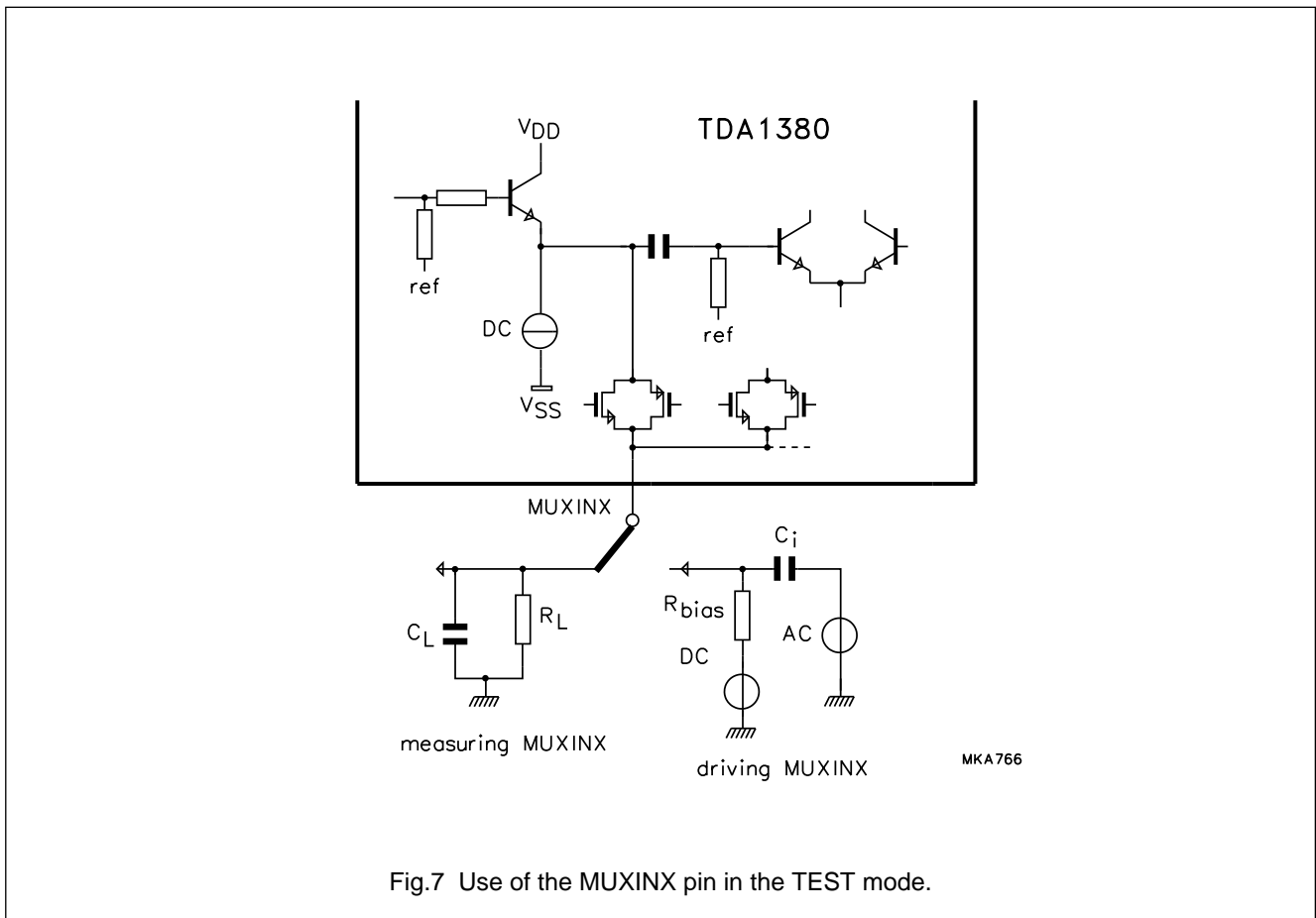
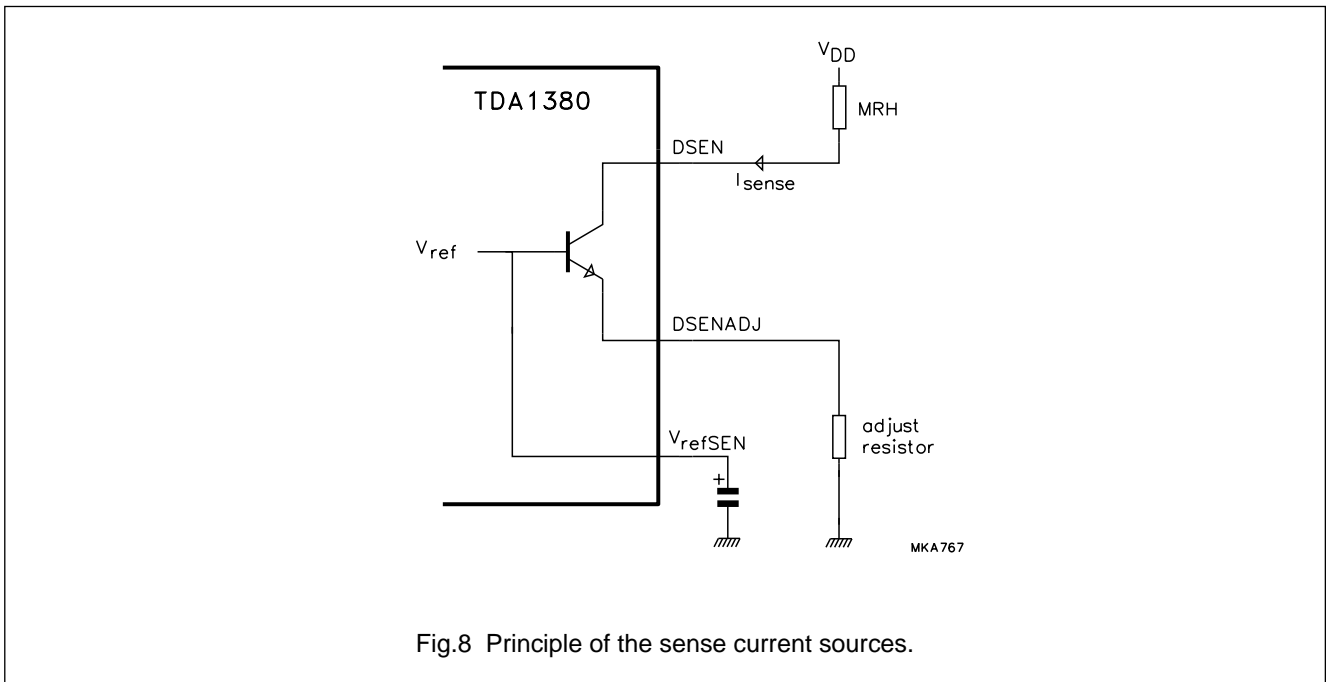

Fig.7 Use of the MUXINX pin in the TEST mode.

DCC read amplifier (READ 3)

TDA1380



The feedback amplifiers consist of three operational amplifiers providing one input and a differential output with respect to an internal 1.15 V reference. The active output A or B is selected by the tape sector selection signal AB.

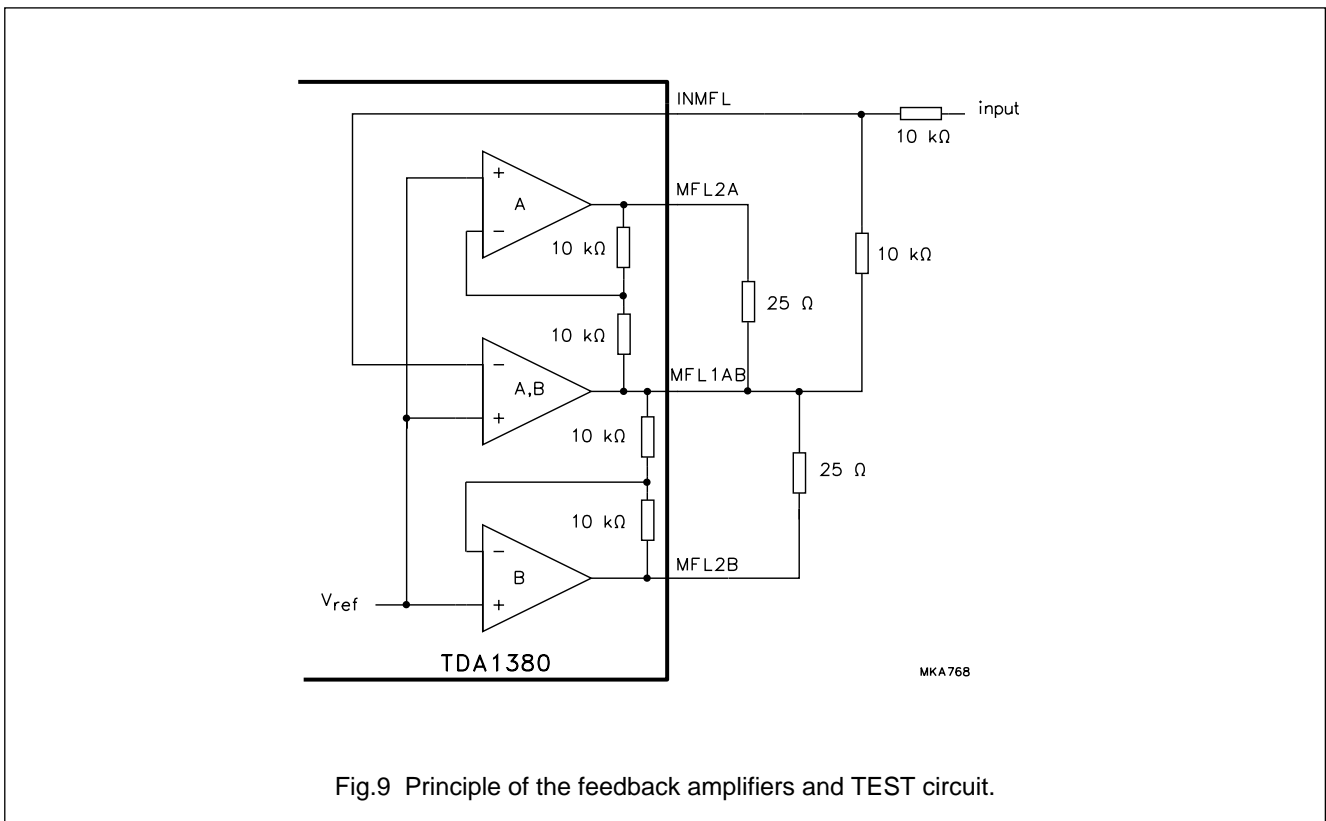

DCC read amplifier (READ 3)

TDA1380

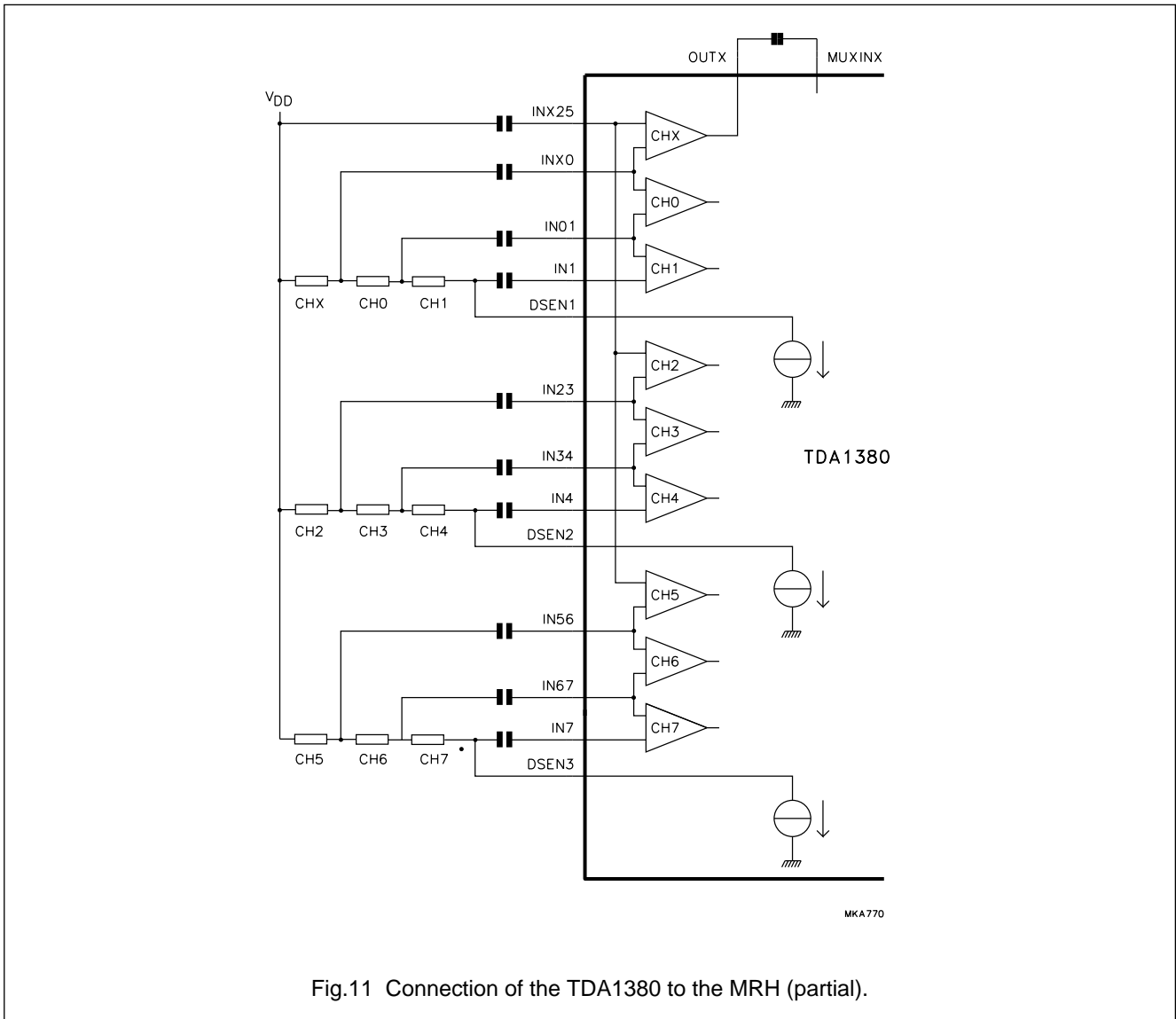
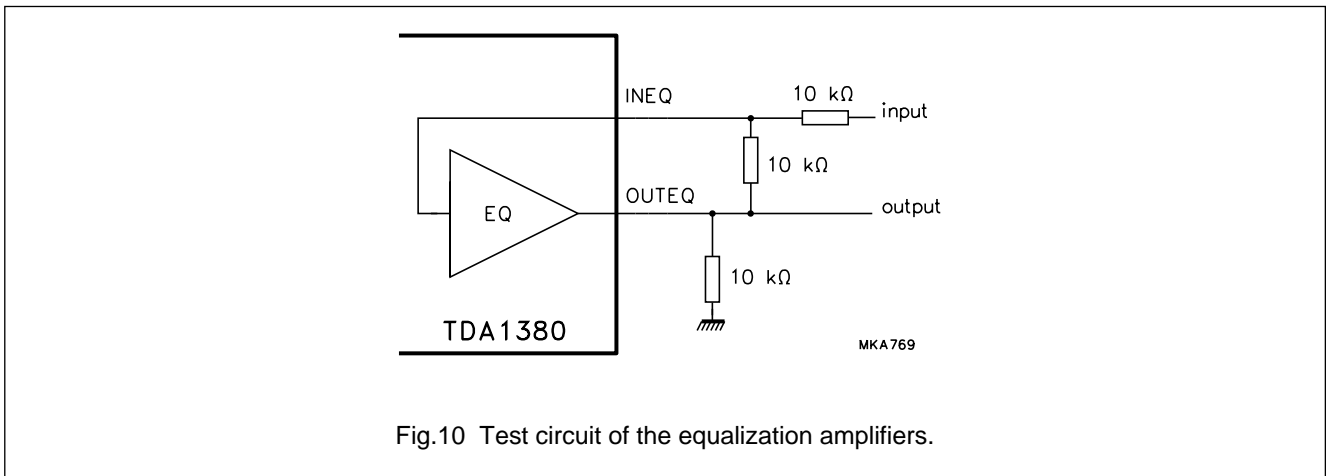

DCC read amplifier (READ 3)

TDA1380

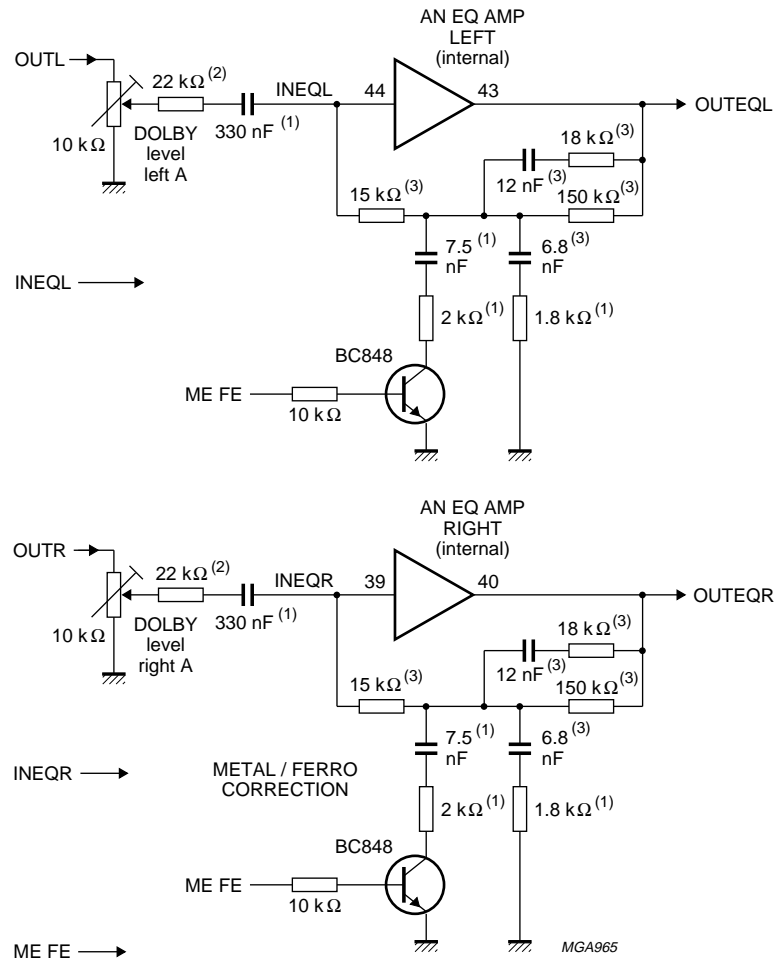

Frequency compensation values are totally dependent on head frequency response characteristics.
(1) Less than 10%.
(2) Less than 5%.
(3) Less than 2%.

Fig.12 Analog equalizer.

DCC read amplifier (READ 3)

TDA1380

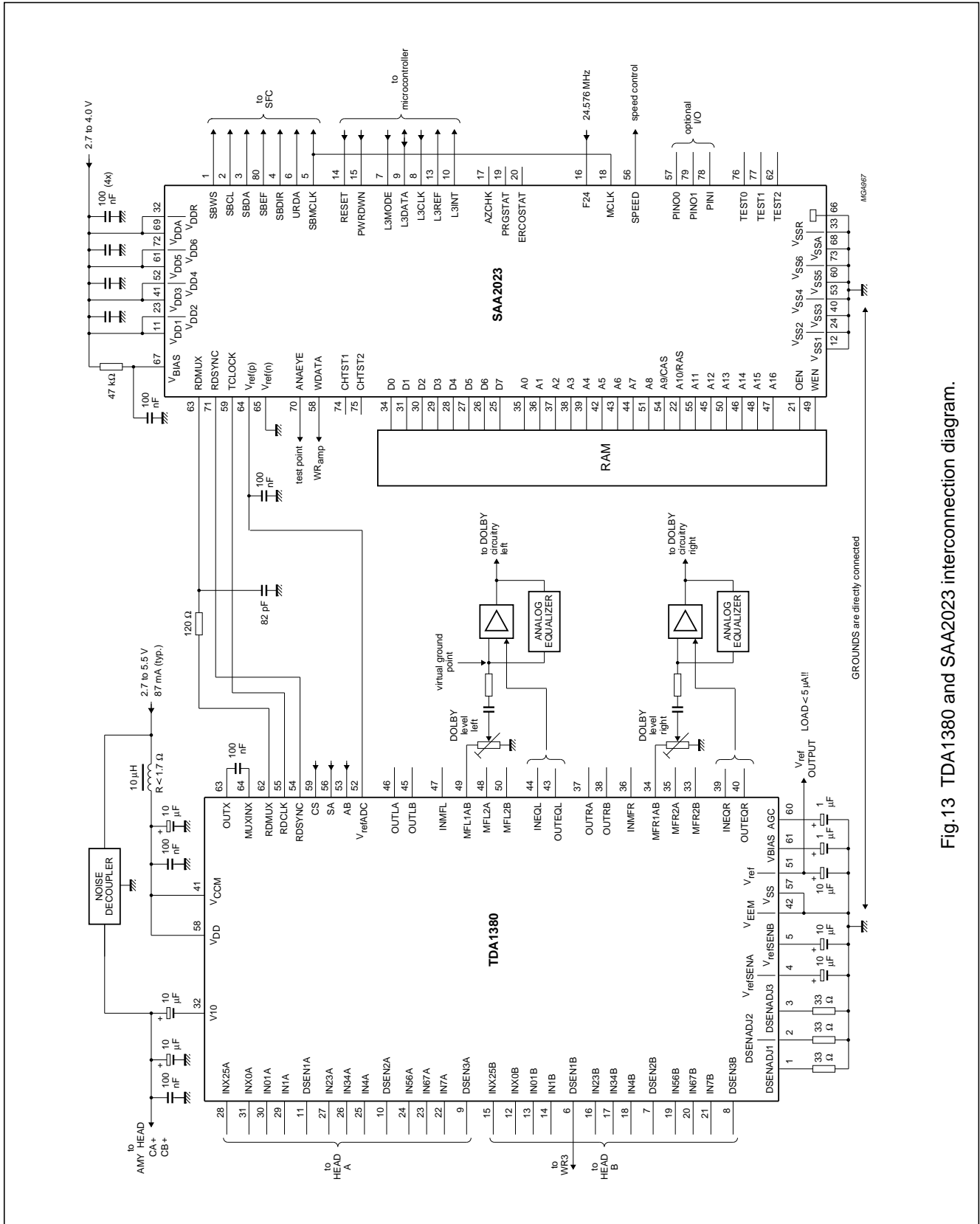
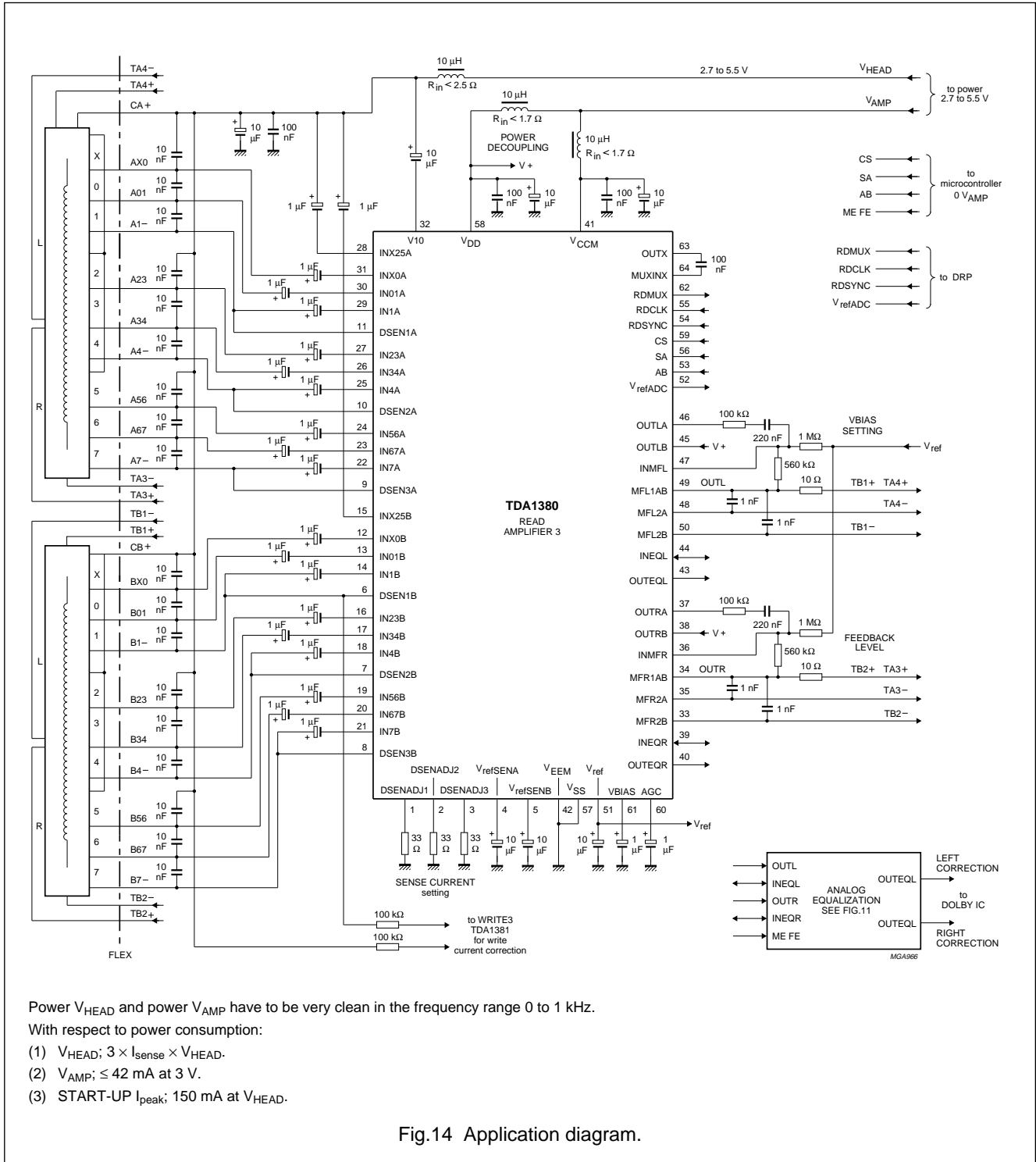

Fig.13 TDA1380 and SAA2023 interconnection diagram.

DCC read amplifier (READ 3)

TDA1380



DCC read amplifier (READ 3)

TDA1380

PACKAGE OUTLINE

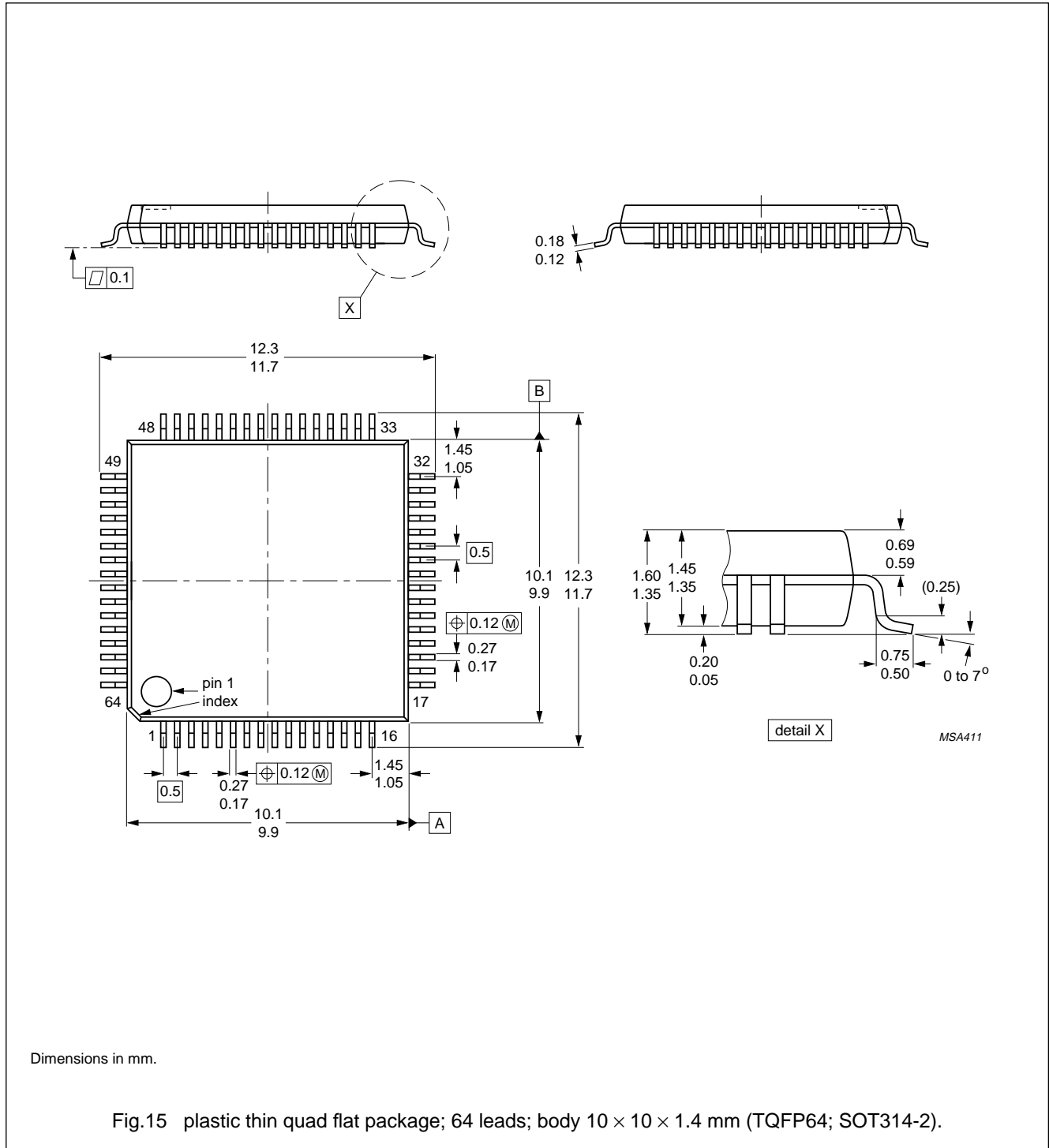

DCC read amplifier (READ 3)**TDA1380**

SOLDERING**Plastic quad flat-packs**

BY WAVE

During placement and before soldering, the component must be fixed with a droplet of adhesive. After curing the adhesive, the component can be soldered. The adhesive can be applied by screen printing, pin transfer or syringe dispensing.

Maximum permissible solder temperature is 260 °C, and maximum duration of package immersion in solder bath is 10 s, if allowed to cool to less than 150 °C within 6 s. Typical dwell time is 4 s at 250 °C.

A modified wave soldering technique is recommended using two solder waves (dual-wave), in which a turbulent wave with high upward pressure is followed by a smooth laminar wave. Using a mildly-activated flux eliminates the need for removal of corrosive residues in most applications.

BY SOLDER PASTE REFLOW

Reflow soldering requires the solder paste (a suspension of fine solder particles, flux and binding agent) to be applied to the substrate by screen printing, stencilling or pressure-syringe dispensing before device placement.

Several techniques exist for reflowing; for example, thermal conduction by heated belt, infrared, and vapour-phase reflow. Dwell times vary between 50 and 300 s according to method. Typical reflow temperatures range from 215 to 250 °C.

Preheating is necessary to dry the paste and evaporate the binding agent. Preheating duration: 45 min at 45 °C.

REPAIRING SOLDERED JOINTS (BY HAND-HELD SOLDERING IRON OR PULSE-HEATED SOLDER TOOL)

Fix the component by first soldering two, diagonally opposite, end pins. Apply the heating tool to the flat part of the pin only. Contact time must be limited to 10 s at up to 300 °C. When using proper tools, all other pins can be soldered in one operation within 2 to 5 s at between 270 and 320 °C. (Pulse-heated soldering is not recommended for SO packages.)

For pulse-heated solder tool (resistance) soldering of VSO packages, solder is applied to the substrate by dipping or by an extra thick tin/lead plating before package placement.

DCC read amplifier (READ 3)

TDA1380

DEFINITIONS

Data sheet status	
Objective specification	This data sheet contains target or goal specifications for product development.
Preliminary specification	This data sheet contains preliminary data; supplementary data may be published later.
Product specification	This data sheet contains final product specifications.
Limiting values	
Limiting values given are in accordance with the Absolute Maximum Rating System (IEC 134). Stress above one or more of the limiting values may cause permanent damage to the device. These are stress ratings only and operation of the device at these or at any other conditions above those given in the Characteristics sections of the specification is not implied. Exposure to limiting values for extended periods may affect device reliability.	
Application information	
Where application information is given, it is advisory and does not form part of the specification.	

LIFE SUPPORT APPLICATIONS

These products are not designed for use in life support appliances, devices, or systems where malfunction of these products can reasonably be expected to result in personal injury. Philips customers using or selling these products for use in such applications do so at their own risk and agree to fully indemnify Philips for any damages resulting from such improper use or sale.



The Digital Compact Cassette logo is a registered trade mark of Philips Electronics N.V.

Philips Semiconductors – a worldwide company

Argentina: IEROD, Av. Juramento 1992 - 14.b, (1428)
BUENOS AIRES, Tel. (541)786 7633, Fax. (541)786 9367

Australia: 34 Waterloo Road, NORTH RYDE, NSW 2113,
Tel. (02)805 4455, Fax. (02)805 4466

Austria: Triester Str. 64, A-1101 WIEN, P.O. Box 213,
Tel. (01)60 101-1236, Fax. (01)60 101-1211

Belgium: Postbus 90050, 5600 PB EINDHOVEN, The Netherlands,
Tel. (31)40 783 749, Fax. (31)40 788 399

Brazil: Rua do Rocio 220 - 5th floor, Suite 51,
CEP: 04552-903-SÃO PAULO-SP, Brazil.
P.O. Box 7383 (01064-970).

Tel. (011)821-2333, Fax. (011)829-1849

Canada: PHILIPS SEMICONDUCTORS/COMPONENTS:
Tel. (800) 234-7381, Fax. (708) 296-8556

Chile: Av. Santa Maria 0760, SANTIAGO,
Tel. (02)773 816, Fax. (02)777 6730

Colombia: IPRELENZO LTDA, Carrera 21 No. 56-17,
77621 BOGOTA, Tel. (571)249 7624/(571)217 4609,
Fax. (571)217 4549

Denmark: Prags Boulevard 80, PB 1919, DK-2300 COPENHAGEN S,
Tel. (032)88 2636, Fax. (031)57 1949

Finland: Sinikalliontie 3, FIN-02630 ESPOO,
Tel. (9)0-50261, Fax. (9)0-520971

France: 4 Rue du Port-aux-Vins, BP317,
92156 SURESNES Cedex,
Tel. (01)4099 6161, Fax. (01)4099 6427

Germany: P.O. Box 10 63 23, 20043 HAMBURG,
Tel. (040)3296-0, Fax. (040)3296 213.

Greece: No. 15, 25th March Street, GR 17778 TAVROS,
Tel. (01)4894 339/4894 911, Fax. (01)4814 240

Hong Kong: PHILIPS HONG KONG Ltd., 6/F Philips Ind. Bldg.,
24-28 Kung Yip St., KWAI CHUNG, N.T.,
Tel. (852)424 5121, Fax. (852)428 6729

India: Philips INDIA Ltd, Shivsagar Estate, A Block,
Dr. Annie Besant Rd. Worli, Bombay 400 018
Tel. (022)4938 541, Fax. (022)4938 722

Indonesia: Philips House, Jalan H.R. Rasuna Said Kav. 3-4,
P.O. Box 4252, JAKARTA 12950,
Tel. (021)5201 122, Fax. (021)5205 189

Ireland: Newstead, Clonskeagh, DUBLIN 14,
Tel. (01)640 000, Fax. (01)640 200

Italy: PHILIPS SEMICONDUCTORS S.r.l.,
Piazza IV Novembre 3, 20124 MILANO,
Tel. (0039)2 6752 2531, Fax. (0039)2 6752 2557

Japan: Philips Bldg 13-37, Kohnan2-chome, Minato-ku, TOKYO 108,
Tel. (03)3740 5028, Fax. (03)3740 0580

Korea: (Republic of) Philips House, 260-199 Itaewon-dong,
Yongsan-ku, SEOUL, Tel. (02)794-5011, Fax. (02)798-8022

Malaysia: No. 76 Jalan Universiti, 46200 PETALING JAYA,
SELANGOR, Tel. (03)750 5214, Fax. (03)757 4880

Mexico: 5900 Gateway East, Suite 200, EL PASO, TX 79905,
Tel. 9-5(800)234-7381, Fax. (708)296-8556

Netherlands: Postbus 90050, 5600 PB EINDHOVEN, Bldg. VB
Tel. (040)783749, Fax. (040)788399

New Zealand: 2 Wagener Place, C.P.O. Box 1041, AUCKLAND,
Tel. (09)849-4160, Fax. (09)849-7811

Norway: Box 1, Manglerud 0612, OSLO,
Tel. (022)74 8000, Fax. (022)74 8341

Pakistan: Philips Electrical Industries of Pakistan Ltd.,
Exchange Bldg. ST-2/A, Block 9, KDA Scheme 5, Clifton,
KARACHI 75600, Tel. (021)587 4641-49,
Fax. (021)577035/5874546.

Philippines: PHILIPS SEMICONDUCTORS PHILIPPINES Inc,
106 Valero St. Salcedo Village, P.O. Box 2108 MCC, MAKATI,
Metro MANILA, Tel. (02)810 0161, Fax. (02)817 3474

Portugal: PHILIPS PORTUGUESA, S.A.,
Rua dr. António Loureiro Borges 5, Arquiparque - Miraflores,
Apartado 300, 2795 LINDA-A-VELHA,
Tel. (01)4163160/4163333, Fax. (01)4163174/4163366.

Singapore: Lorong 1, Toa Payoh, SINGAPORE 1231,
Tel. (65)350 2000, Fax. (65)251 6500

South Africa: S.A. PHILIPS Pty Ltd.,
195-215 Main Road Martindale, 2092 JOHANNESBURG,
P.O. Box 7430 Johannesburg 2000,
Tel. (011)470-5911, Fax. (011)470-5494.

Spain: Balmes 22, 08007 BARCELONA,
Tel. (03)301 6312, Fax. (03)301 42 43

Sweden: Kottbygatan 7, Akalla. S-164 85 STOCKHOLM,
Tel. (0)8-632 2000, Fax. (0)8-632 2745

Switzerland: Allmendstrasse 140, CH-8027 ZÜRICH,
Tel. (01)488 2211, Fax. (01)481 77 30

Taiwan: PHILIPS TAIWAN Ltd., 23-30F, 66, Chung Hsiao West
Road, Sec. 1. Taipei, Taiwan ROC, P.O. Box 22978,
TAIPEI 100, Tel. (02)388 7666, Fax. (02)382 4382.

Thailand: PHILIPS ELECTRONICS (THAILAND) Ltd.,
209/2 Sanpavuth-Bangna Road Prakanong,
Bangkok 10260, THAILAND,
Tel. (662)398-0141, Fax. (662)398-3319.

Turkey: Talatpasa Cad. No. 5, 80640 GÜLTEPE/ISTANBUL,
Tel. (0212)279 2770, Fax. (0212)269 3094

United Kingdom: Philips Semiconductors LTD.,
276 Bath road, Hayes, MIDDLESEX UB3 5BX,
Tel. (081)73050000, Fax. (081)7548421

United States: 811 East Arques Avenue, SUNNYVALE,
CA 94088-3409, Tel. (800)234-7381, Fax. (708)296-8556

Uruguay: Coronel Mora 433, MONTEVIDEO,
Tel. (02)70-4044, Fax. (02)92 0601

For all other countries apply to: Philips Semiconductors,
International Marketing and Sales, Building BE-p,
P.O. Box 218, 5600 MD, EINDHOVEN, The Netherlands,
Telex 35000 phtcnl, Fax. +31-40-724825

SCD35 © Philips Electronics N.V. 1994

All rights are reserved. Reproduction in whole or in part is prohibited without the prior written consent of the copyright owner.

The information presented in this document does not form part of any quotation or contract, is believed to be accurate and reliable and may be changed without notice. No liability will be accepted by the publisher for any consequence of its use. Publication thereof does not convey nor imply any license under patent- or other industrial or intellectual property rights.

Printed in The Netherlands

Philips Semiconductors



PHILIPS