

Silicon NPN Power Transistors

2SD1413

DESCRIPTION

- With TO-220Fa package
- High DC current gain
- Low saturation voltage
- Complement to type 2SB1023

APPLICATIONS

- Power amplifier and switching applications
- Hammer drive,pulse motor drive applications

PINNING

PIN	DESCRIPTION
1	Base
2	Collector
3	Emitter

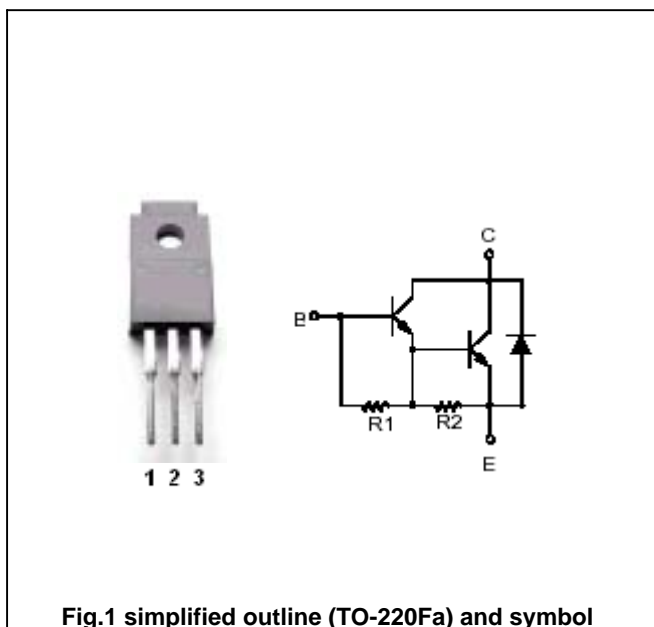

Fig.1 simplified outline (TO-220Fa) and symbol

Absolute maximum ratings($T_a=25$)

SYMBOL	PARAMETER	CONDITIONS	VALUE	UNIT
V_{CBO}	Collector-base voltage	Open emitter	60	V
V_{CEO}	Collector -emitter voltage	Open base	40	V
V_{EBO}	Emitter-base voltage	Open collector	5	V
I_C	Collector current		3	A
I_B	Base current		0.5	A
P_C	Collector power dissipation	$T_C=25$	20	W
T_j	Junction temperature		150	
T_{stg}	Storage temperature		-55~150	

Silicon NPN Power Transistors

2SD1413

CHARACTERISTICS

T_j=25 unless otherwise specified

SYMBOL	PARAMETER	CONDITIONS	MIN	TYP.	MAX	UNIT
V _{(BR)CEO}	Collector-emitter breakdown voltage	I _C =25mA; I _B =0	40			V
V _{CEsat}	Collector-emitter saturation voltage	I _C =2A; I _B =4mA			1.5	V
V _{BEsat}	Base-emitter saturation voltage	I _C =2A; I _B =4mA			2.0	V
I _{CBO}	Collector cut-off current	V _{CB} =60V; I _E =0			20	μA
I _{EBO}	Emitter cut-off current	V _{EB} =5V; I _C =0			2.5	mA
h _{FE-1}	DC current gain	I _C =1A; V _{CE} =2V	2000			
h _{FE-2}	DC current gain	I _C =3A; V _{CE} =2V	1000			

Switching times

t _{on}	Turn-on time	I _{B1} =-I _{B2} =6mA V _{CC} =30V, R _L =10		0.1		μs
t _{stg}	Storage time			1.0		μs
t _f	Fall time			0.2		μs

Silicon NPN Power Transistors

2SD1413

PACKAGE OUTLINE

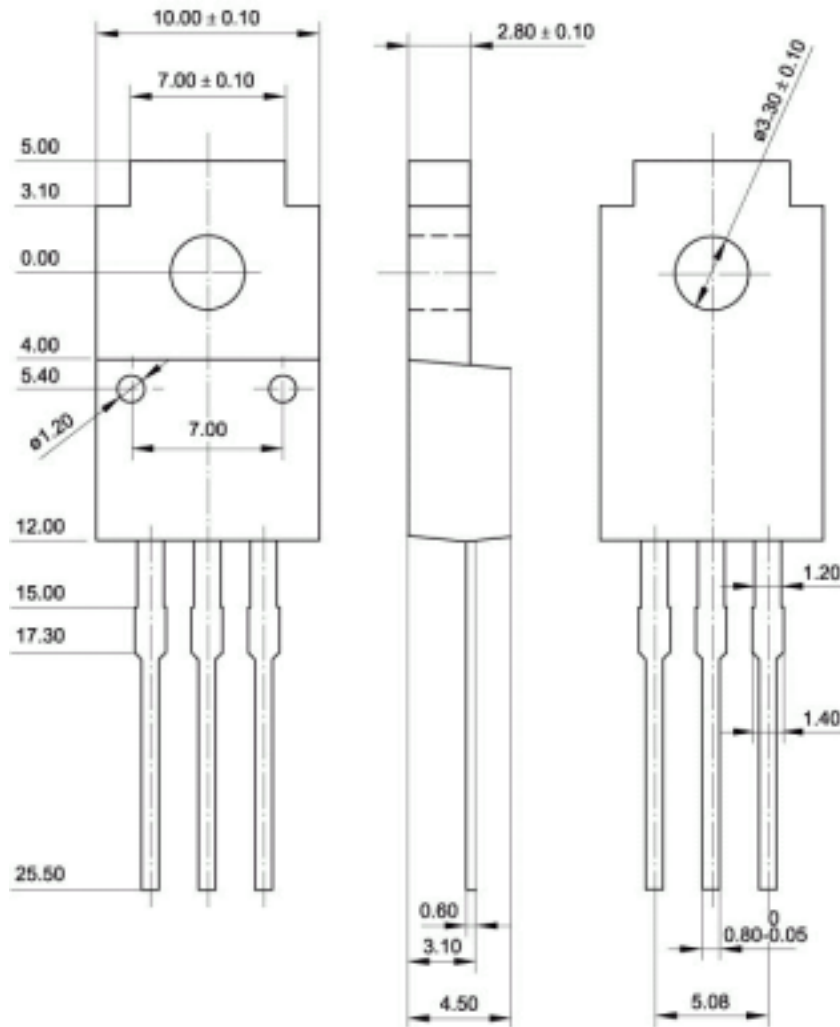

Fig.2 Outline dimensions (unindicated tolerance: ± 0.15 mm)