

# 1A / 60V Digital Transistor (with built-in resistor and zener diode)

## DTDG14GP

●Applications

Driver

●Features

- 1) High  $h_{FE}$ .  
300 (Min.) ( $V_{CE} / I_C = 2V / 0.5A$ )
- 2) Low saturation voltage,  
( $V_{CE(sat)} = 0.4V$  at  $I_C / I_B = 500mA / 5mA$ )
- 3) Built-in zener diode gives strong protection against reverse surge by L- load (an inductive load).

●Structure

NPN epitaxial planar silicon transistor  
(with built-in resistor and zener diode)

●Packaging specifications

Part No.	Package	MPT3
	Packaging type	Taping
	Code	T100
	Basic ordering unit (pieces)	1000
DTDG14GP		○

●External dimensions (Unit : mm)

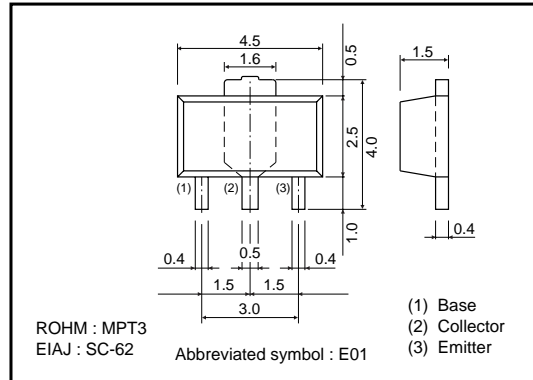

●Equivalent circuit

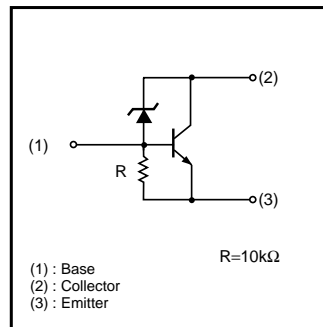

●Absolute maximum ratings ( $T_a = 25^\circ C$ )

Parameter	Symbol	Limits	Unit
Collector-base voltage	$V_{CBO}$	60±10	V
Collector-emitter voltage	$V_{CEO}$	60±10	V
Emitter-base voltage	$V_{EBO}$	5	V
Collector current	$I_C$	1	A
	$I_{CP}$	2 *1	A
Collector power dissipation	$P_C$	0.5	W
		2 *2	
Junction temperature	$T_j$	150	°C
Storage temperature	$T_{stg}$	-55 to +150	°C

\*1  $P_w \leq 10ms$ , Duty cycle  $\leq 1/2$

\*2 When mounted on a 40×40×0.7 mm ceramic board.

Transistors

●Electrical characteristics (Ta = 25°C)

Parameter	Symbol	Min.	Typ.	Max.	Unit	Conditions
Collector-base breakdown voltage	BV <sub>CBO</sub>	50	–	70	V	I <sub>c</sub> =50μA
Collector-emitter breakdown voltage	BV <sub>CEO</sub>	50	–	70	V	I <sub>c</sub> =1mA
Emitter-base breakdown voltage	BV <sub>EBO</sub>	5	–	–	V	I <sub>E</sub> =720μA
Collector cutoff current	I <sub>CBO</sub>	–	–	0.5	μA	V <sub>CB</sub> =40V
Emitter cutoff current	I <sub>EBO</sub>	300	–	580	μA	V <sub>EB</sub> =4V
Collector-emitter saturation voltage	V <sub>CE(sat)</sub>	–	–	0.4	V	I <sub>c</sub> /I <sub>B</sub> =500mA/5mA
DC current transfer ratio	h <sub>FE</sub>	300	–	–	–	V <sub>CE</sub> =2V, I <sub>c</sub> =500mA
Emitter-base resistance	R	7	10	13	kΩ	–
Transition frequency	f <sub>t</sub> *	–	80	–	MHz	V <sub>CE</sub> =5V, I <sub>E</sub> =–0.1A, f=30MHz

\* Characteristics of built-in transistor

●Electrical characteristic curves

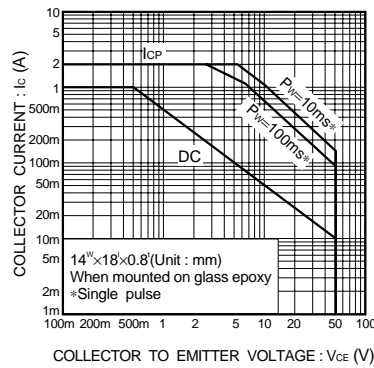

Fig.1 Safe operating area

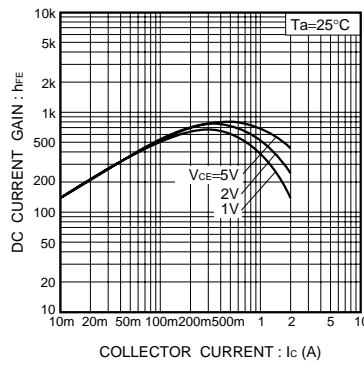

Fig.2 DC current gain vs. collector current

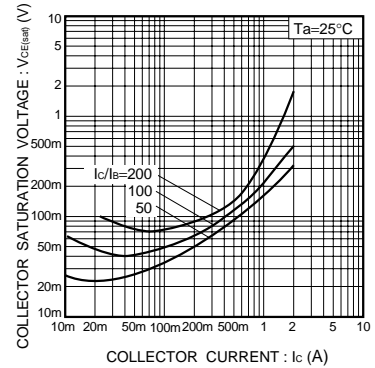

Fig.3 Collector-emitter saturation voltage vs. collector current