

## NPN Silicon Epitaxial Planar Transistor

## FMMT491

### FEATURES

- Low saturation.
- Complementary To FMMT591.
- Excellent  $H_{FE}$  Linearity.

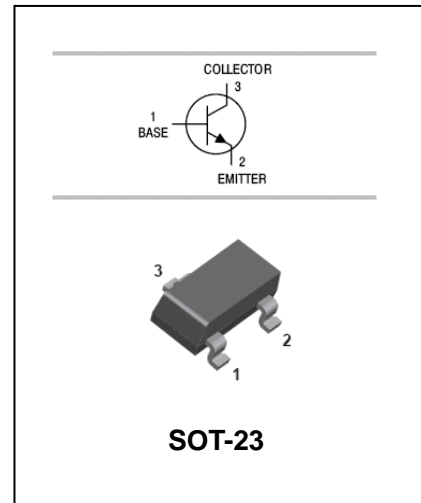

### APPLICATIONS

- Switching application.

### ORDERING INFORMATION

Type No.	Marking	Package Code
FMMT491	491	SOT-23

### MAXIMUM RATING @ $T_a=25^\circ\text{C}$ unless otherwise specified

Symbol	Parameter	Value	Units
$V_{CBO}$	Collector-Base Voltage	80	V
$V_{CEO}$	Collector-Emitter Voltage	60	V
$V_{EBO}$	Emitter-Base Voltage	5	V
$I_C$	Collector Current -Continuous	1000	mA
$P_C$	Collector Dissipation	500	mW
$T_j, T_{stg}$	Junction and Storage Temperature	-55~150	$^\circ\text{C}$

**NPN Silicon Epitaxial Planar Transistor****FMMT491****ELECTRICAL CHARACTERISTICS @ Ta=25°C unless otherwise specified**

Parameter	Symbol	Test conditions	MIN	TYP	MAX	UNIT
Collector-base breakdown voltage	$V_{(BR)CBO}$	$I_C=100\mu A, I_E=0$	80			V
Collector-emitter breakdown voltage	$V_{(BR)CEO}$	$I_C=10mA, I_B=0$	60			V
Emitter-base breakdown voltage	$V_{(BR)EBO}$	$I_E=100\mu A, I_C=0$	5			V
Collector cut-off current	$I_{CBO}$	$V_{CB}=60V, I_E=0$			0.1	$\mu A$
Emitter cut-off current	$I_{EBO}$	$V_{EB}=4V, I_C=0$			0.1	$\mu A$
DC current gain	$h_{FE}$	$V_{CE}=5V, I_C=1mA$	100			
		$V_{CE}=5V, I_C=500mA$	100		300	
		$V_{CE}=5V, I_C=1A$	80			
		$V_{CE}=5V, I_C=2A$	30			
Collector-emitter saturation voltage	$V_{CE(sat)}$	$I_C=500mA, I_B=50mA$ $I_C=1A, I_B=100mA$			0.25 0.5	V
Base-emitter saturation voltage	$V_{BE(sat)}$	$I_C=1A, I_B=100mA$			1.1	V
Transition frequency	$f_T$	$V_{CE}=10V, I_C=50mA$ $f=100MHz$	150			MHz
Collector output capacitance	$C_{ob}$	$V_{CB}=10V, f=1MHz$			10	pF

## NPN Silicon Epitaxial Planar Transistor

## FMMT491

TYPICAL CHARACTERISTICS @ Ta=25°C unless otherwise specified

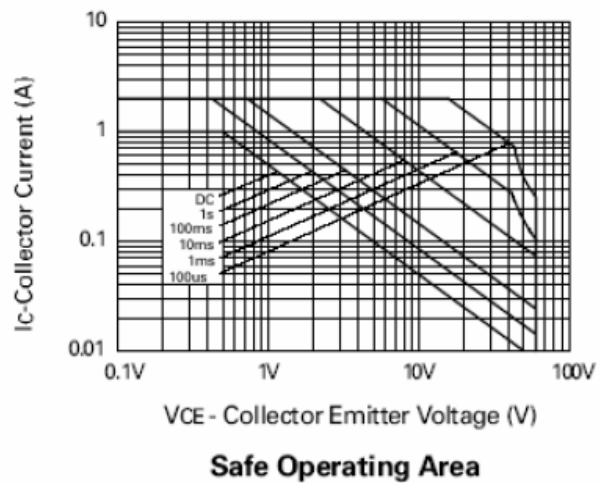
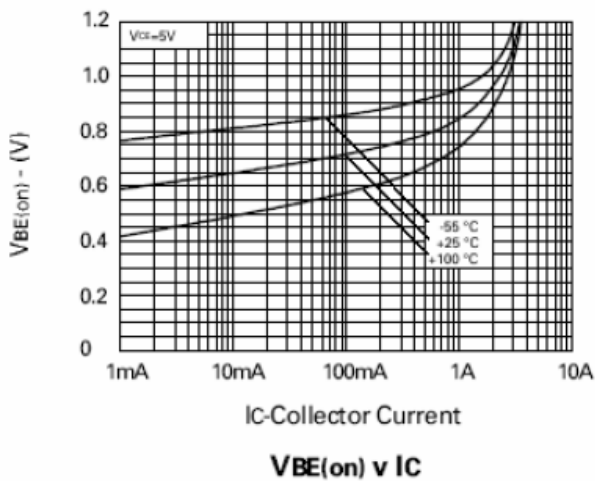
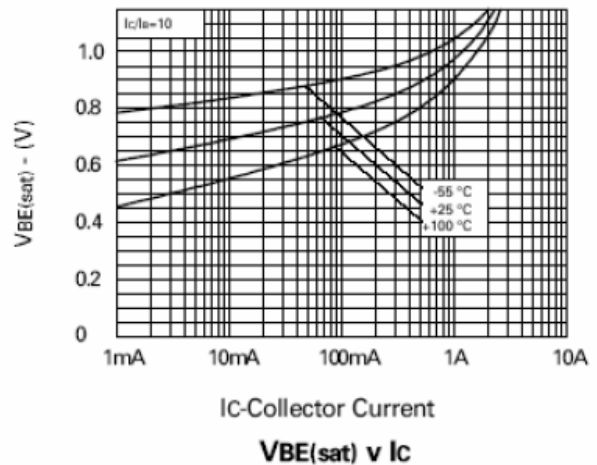
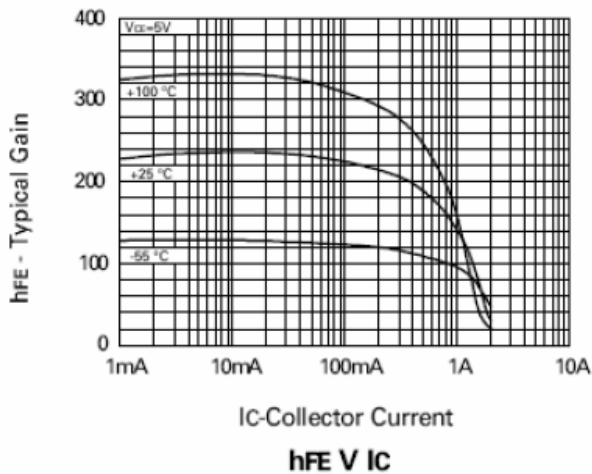
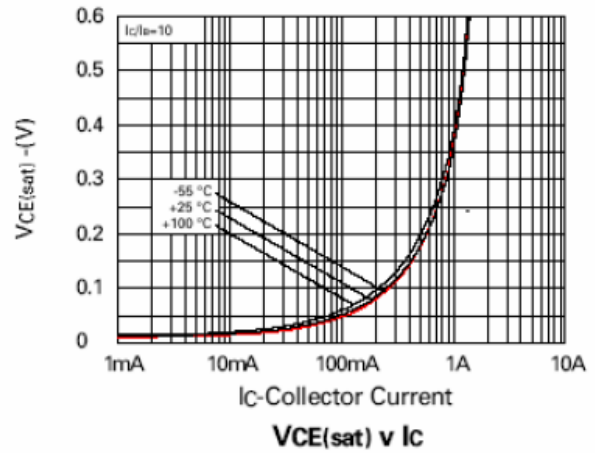
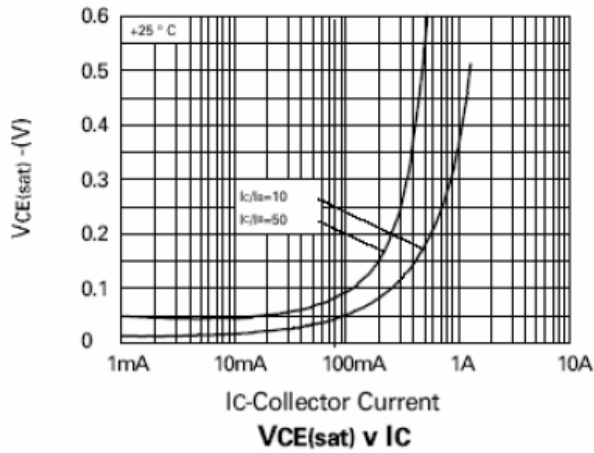

## NPN Silicon Epitaxial Planar Transistor

## FMMT491

### PACKAGE OUTLINE

Plastic surface mounted package

SOT-23

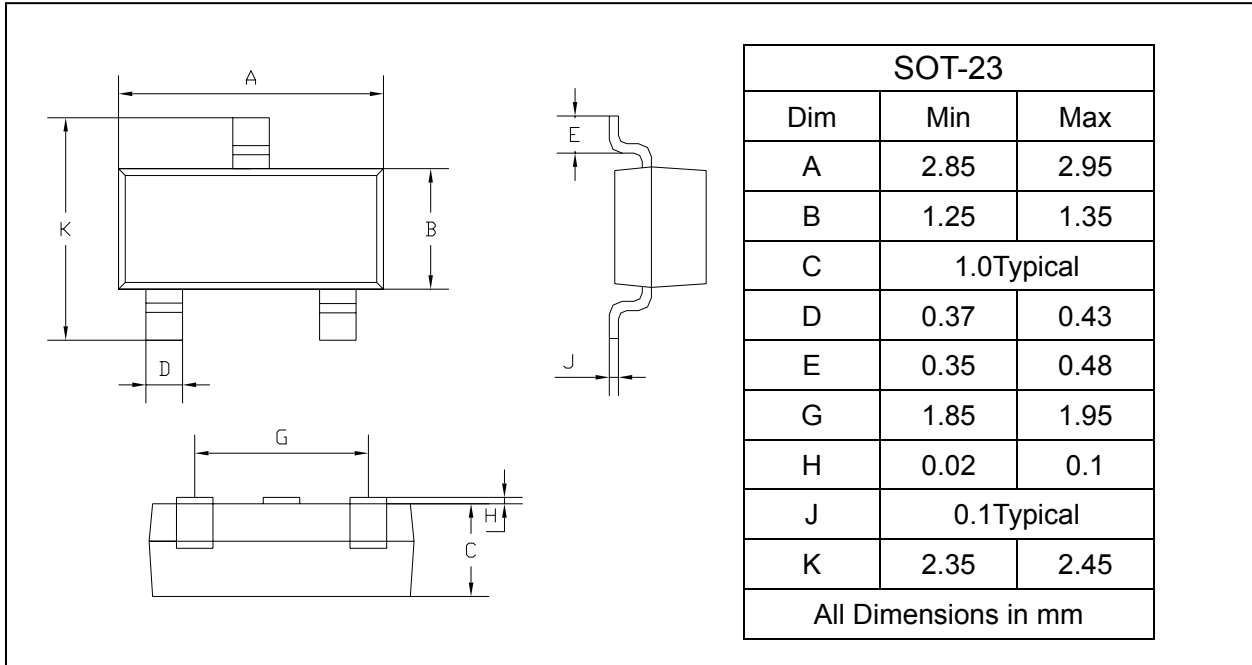

### SOLDERING FOOTPRINT

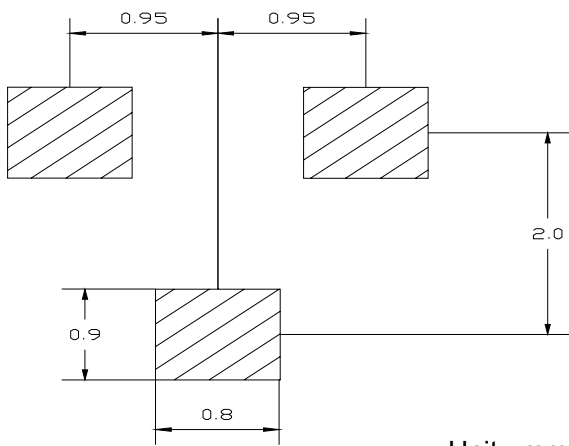

### PACKAGE INFORMATION

Device	Package	Shipping
FMMT491	SOT-23	3000/Tape&Reel