

N-CHANNEL MOSFET

MTNK1N3

Description

The MTKN1N3 is a N-channel enhancement-mode MOSFET.

Features

- Low on-resistance
- High ESD
- High speed switching
- Low-voltage drive(4V)
- Easily designed drive circuits
- Easy to use in parallel
- Pb-free package

Symbol

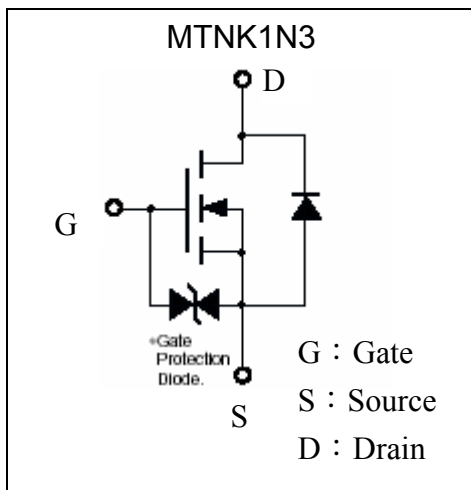

Outline

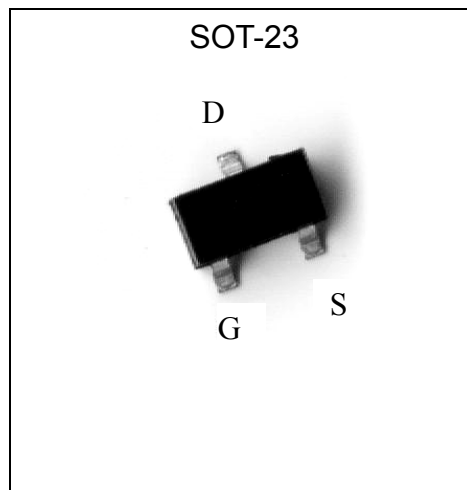



Absolute Maximum Ratings (Ta=25°C)

Parameter		Symbol	Limits	Unit
Drain-Source Voltage		V _{DSS}	60	V
Gate-Source Voltage		V _{GSS}	±20	V
Drain Current	Continuous	I _D	115	mA
	Pulsed	I _{DP}	700 *1	mA
Drain Reverse Current	Continuous	I _{DR}	115	mA
	Pulsed	I _{DRP}	700 *1	mA
Total Power Dissipation		P _D	200 *2	mW
ESD susceptibility			1250 *3	V
Channel Temperature		T _{CH}	+150	°C
Storage Temperature		T _{stg}	-55~+150	°C

Note : *1. Pulse Width ≤ 300µs, Duty cycle ≤ 2%

*2. When the device is mounted on a glass epoxy board with area measuring 1x0.75x0.62 inch

*3. Human body model, 1.5kΩ in series with 100pF

Electrical Characteristics (Ta=25°C)

Symbol	Min.	Typ.	Max.	Unit	Test Conditions
BV _{DSS} *	60	-	-	V	V _{GS} =0, I _D =10µA
V _{GS(th)}	1	-	2.5	V	V _{DS} =V _{GS} , I _D =250µA
I _{GSS}	-	-	±10	µA	V _{GS} =±20V, V _{DS} =0
I _{DSS}	-	-	1	µA	V _{DS} =60V, V _{GS} =0
R _{DS(on)} *	-	3.6	5.5	Ω	I _D =100mA, V _{GS} =5V
	-	3	5		I _D =100mA, V _{GS} =10V
G _{FS}	100	-	-	mS	V _{DS} =10V, I _D =100mA
C _{iss}	-	7.32	-	pF	V _{DS} =10V, V _{GS} =0, f=1MHz
C _{oss}	-	3.42	-		
C _{rss}	-	7.63	-		
td(on)	-	1.2	-	ns	V _{DD} =30V, I _D =200mA, R _{GS} =25 Ω, V _{GS} =10V, R _L =15 Ω
tr	-	1	-		
td(off)	-	1.1	-		
tf	-	2.2	-		

*Pulse Test : Pulse Width ≤ 380µs, Duty Cycle ≤ 2%

Ordering Information

Device	Package	Shipping	Marking
MTNK1N3	SOT-23 (Pb-free)	3000 pcs / Tape & Reel	702

Characteristic Curves

Typical Output Characteristics

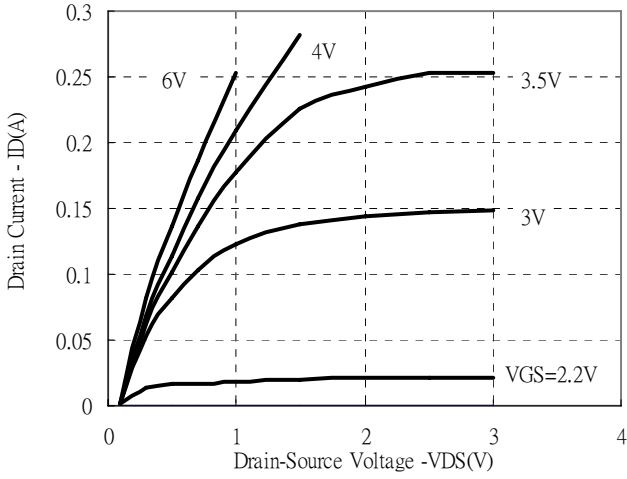

Typical Transfer Characteristics

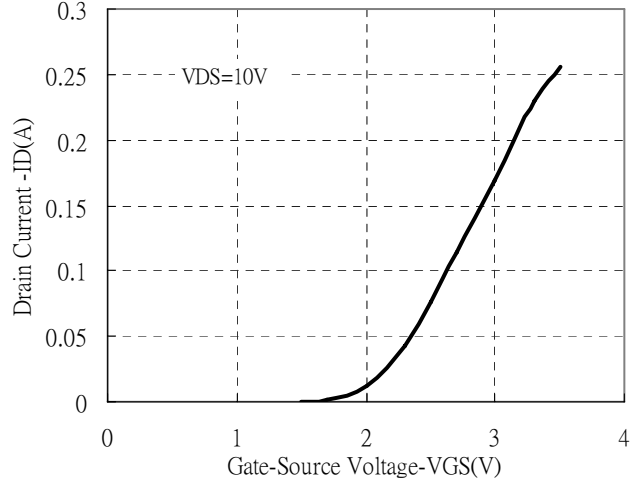

Static Drain-Source On-State resistance vs Drain Current

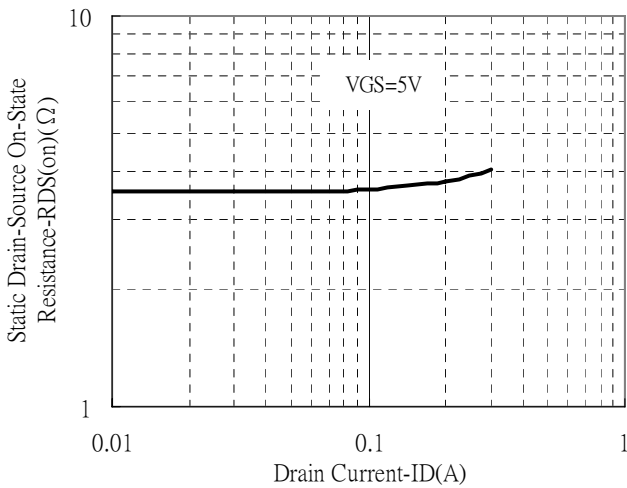

Static Drain-Source On-State resistance vs Drain Current

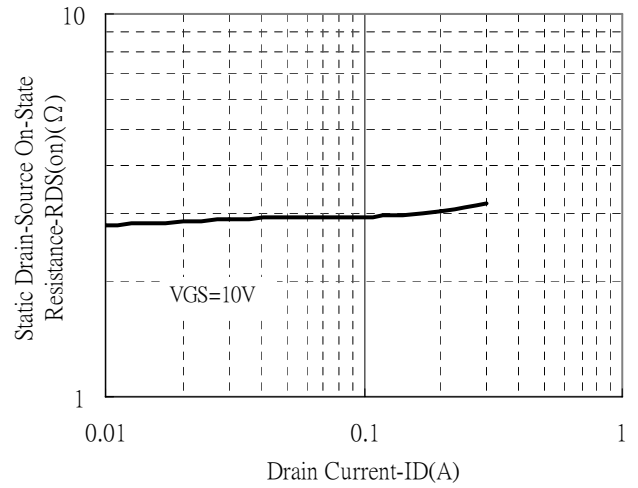

Static Drain-Source On-State Resistance vs Gate-Source Voltage

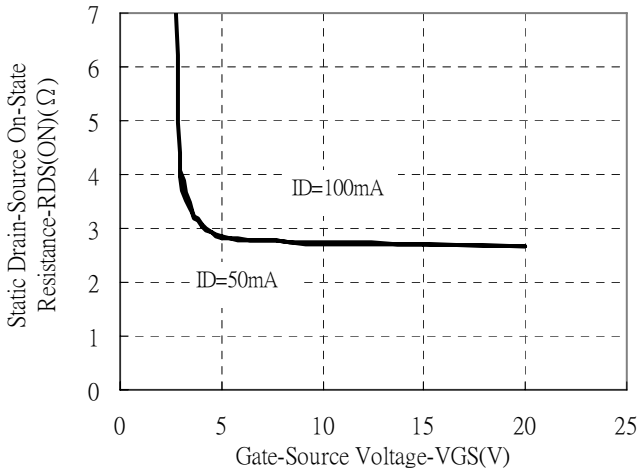

Reverse Drain Current vs Source-Drain Voltage

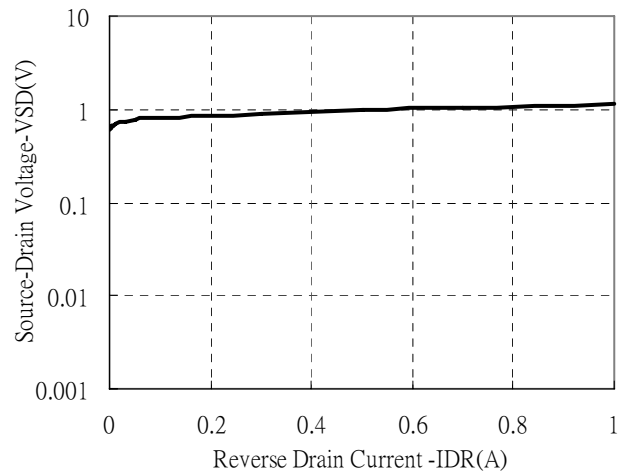



Characteristic Curves(Cont.)

Capacitance vs Drain-to-Source Voltage

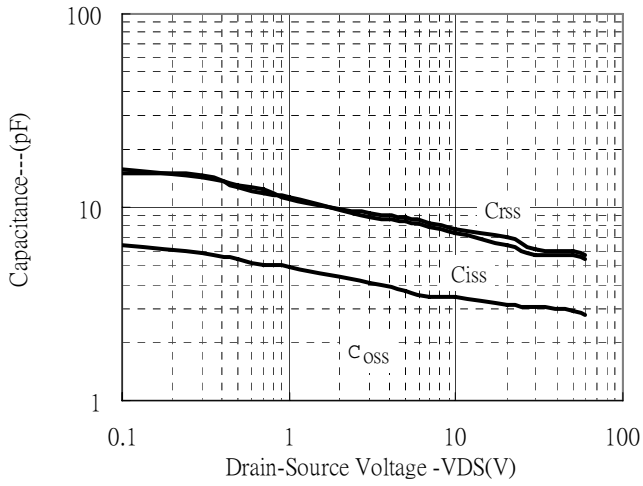

Power Derating Curve

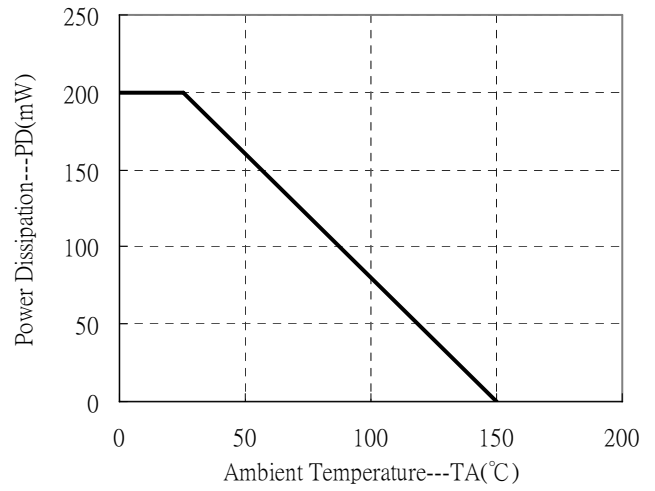

Recommended wave soldering condition

Product	Peak Temperature	Soldering Time
Pb-free devices	260 +0/-5 °C	5 +1/-1 seconds

Recommended temperature profile for IR reflow



Profile feature	Sn-Pb eutectic Assembly	Pb-free Assembly
Average ramp-up rate (Ts _{max} to T _p)	3°C/second max.	3°C/second max.
Preheat		
-Temperature Min(T _s min)	100°C	150°C
-Temperature Max(T _s max)	150°C	200°C
-Time(ts _{min} to ts _{max})	60-120 seconds	60-180 seconds
Time maintained above:		
-Temperature (T _L)	183°C	217°C
- Time (t _L)	60-150 seconds	60-150 seconds
Peak Temperature(T _p)	240 +0/-5 °C	260 +0/-5 °C
Time within 5°C of actual peak temperature(tp)	10-30 seconds	20-40 seconds
Ramp down rate	6°C/second max.	6°C/second max.
Time 25 °C to peak temperature	6 minutes max.	8 minutes max.

Note : All temperatures refer to topside of the package, measured on the package body surface.

SOT-23 Dimension

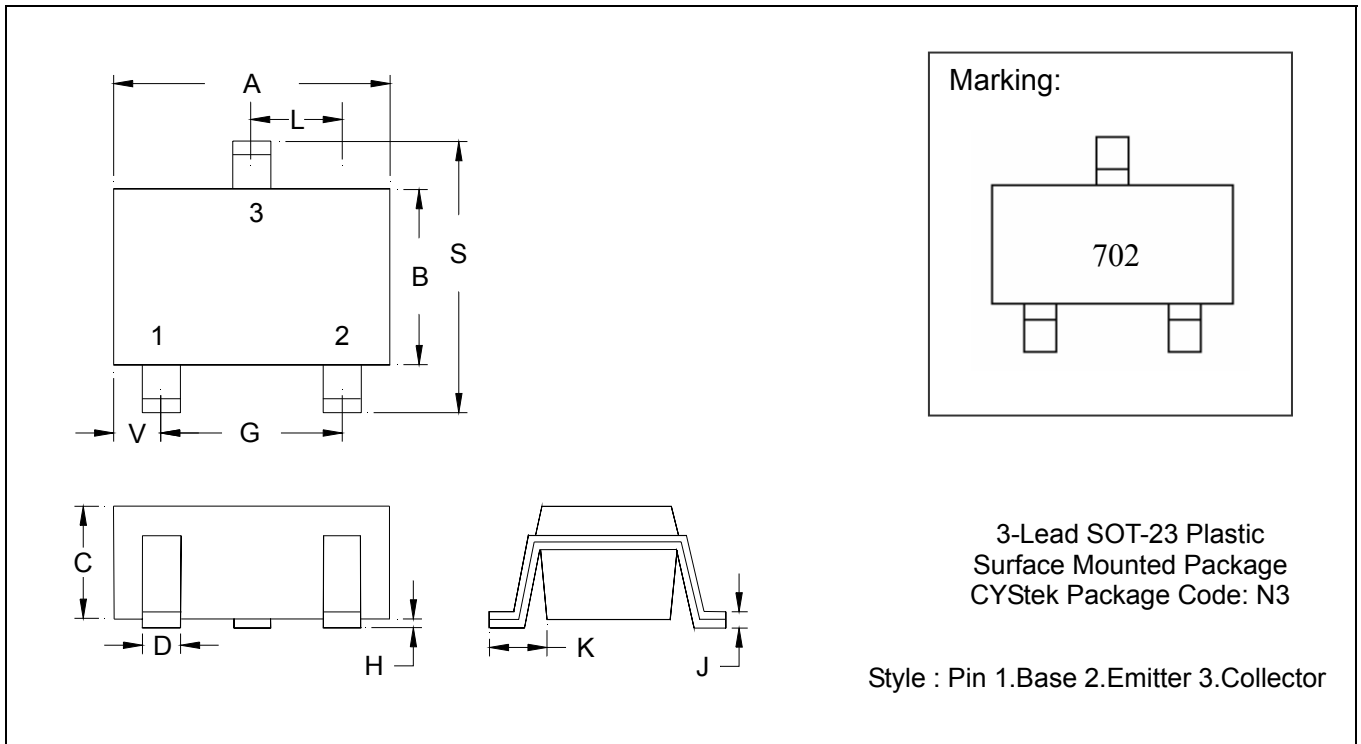

*:Typical

DIM	Inches		Millimeters		DIM	Inches		Millimeters	
	Min.	Max.	Min.	Max.		Min.	Max.	Min.	Max.
A	0.1102	0.1204	2.80	3.04	J	0.0034	0.0070	0.085	0.177
B	0.0472	0.0630	1.20	1.60	K	0.0128	0.0266	0.32	0.67
C	0.0335	0.0512	0.89	1.30	L	0.0335	0.0453	0.85	1.15
D	0.0118	0.0197	0.30	0.50	S	0.0830	0.1083	2.10	2.75
G	0.0669	0.0910	1.70	2.30	V	0.0098	0.0256	0.25	0.65
H	0.0005	0.0040	0.013	0.10					

Notes : 1.Controlling dimension : millimeters.
 2.Maximum lead thickness includes lead finish thickness, and minimum lead thickness is the minimum thickness of base material.
 3.If there is any question with packing specification or packing method, please contact your local CYStek sales office.

Material :

- Lead : 42 Alloy ; pure tin plated
- Mold Compound : Epoxy resin family, flammability solid burning class:UL94V-0

Important Notice:

- All rights are reserved. Reproduction in whole or in part is prohibited without the prior written approval of CYStek.
- CYStek reserves the right to make changes to its products without notice.
- CYStek **semiconductor products are not warranted to be suitable for use in Life-Support Applications, or systems.**
- CYStek assumes no liability for any consequence of customer product design, infringement of patents, or application assistance.