

Compal confidential

Schematics Document Mobile Dothan uFCBGA/uFCPGA with Intel Alviso_GM+ICH6-M core logic 2004-09-09

REV:06

THIS SHEET OF ENGINEERING DRAWING IS THE PROPRIETARY PROPERTY OF COMPAL ELECTRONICS, INC. AND CONTAINS TRADE SECRET AND CONFIDENTIAL INFORMATION. THIS SHEET MAY NOT BE TRANSFERRED FROM THE CUSTODY OF THE COMPETENT DIVISION OF COMPAL ELECTRONICS, INC. WITHOUT THE WRITTEN CONSENT OF COMPAL ELECTRONICS, INC. NEITHER THIS SHEET NOR THE INFORMATION IT CONTAINS MAY BE USED BY OR DISCLOSED TO ANY THIRD PARTY WITHOUT PRIOR WRITTEN CONSENT OF COMPAL ELECTRONICS, INC.

Compal Electronics, Inc.	
Title	Cover Sheet
Document Number	014-211
Rev	0.6
Date	Thursday, September 09, 2004
Sheet	1 of 48

Heavenly

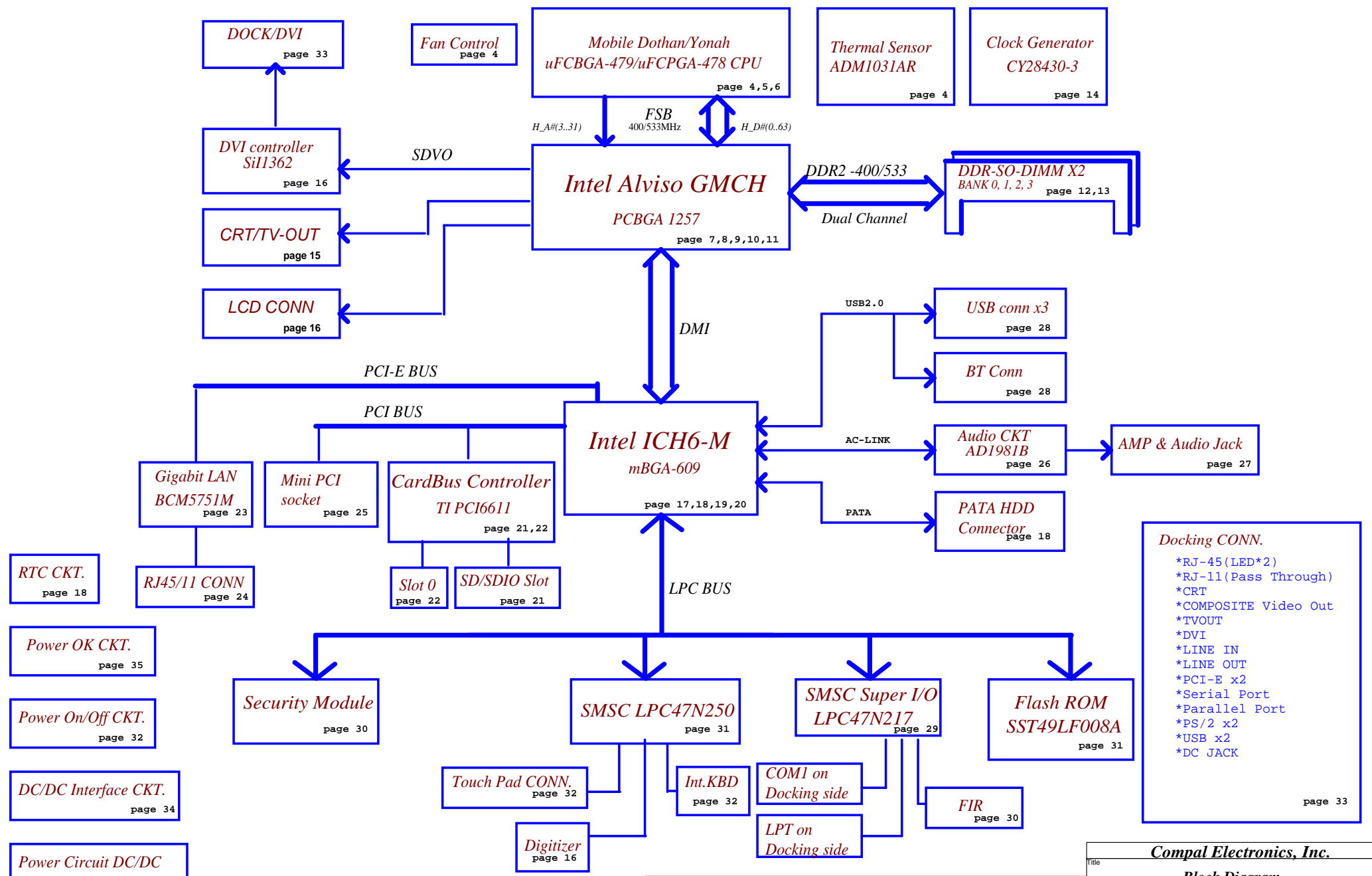

- Docking CONN.**
- *RJ-45 (LED*2)
 - *RJ-11 (Pass Through)
 - *CRT
 - *COMPOSITE Video Out
 - *TVOUT
 - *DVI
 - *LINE IN
 - *LINE OUT
 - *PCI-E x2
 - *Serial Port
 - *Parallel Port
 - *PS/2 x2
 - *USB x2
 - *DC JACK
- page 33

THIS SHEET OF ENGINEERING DRAWING IS THE PROPRIETARY PROPERTY OF COMPAL ELECTRONICS, INC. AND CONTAINS TRADE SECRET INFORMATION. THIS SHEET MAY NOT BE TRANSFERRED FROM THE CUSTODY OF THE COMPETENT DIVISION OF COMPAL ELECTRONICS, INC. DEPARTMENT EXCEPT AS AUTHORIZED BY COMPAL ELECTRONICS, INC. NEITHER THIS SHEET NOR THE INFORMATION IT CONTAINS MAY BE USED BY OR DISCLOSED TO ANY THIRD PARTY WITHOUT PRIOR WRITTEN CONSENT OF COMPAL ELECTRONICS, INC.

Voltage Rails

Power Plane	Description	S0-S1	S3	S5
VIN	Adapter power supply (19V)	N/A	N/A	N/A
B+	AC or battery power rail for power circuit	N/A	N/A	N/A
+CPU_CORE	Core voltage for CPU	ON	OFF	OFF
+VCCP	1.05V power rail for Processor I/O and MCH core power	ON	OFF	OFF
+0.9VS	0.9V switched power rail for DDRII Vtt	ON	OFF	OFF
+1.5VALW	1.5V always on power rail	ON	ON	ON*
+1.5VS	1.5V switched power rail for PCI-E interface	ON	OFF	OFF
+1.8V	1.8V power rail for DDRII	ON	ON	OFF
+1.8VS	1.8V switched power rail	ON	OFF	OFF
+2.5VALW	2.5V always on power rail	ON	ON	ON*
+2.5VS	2.5V switched power rail for MCH video PLL	ON	OFF	OFF
+3VALW	3.3V always on power rail	ON	ON	ON*
+3V	3V power rail	ON	ON	OFF
+3VS	3.3V switched power rail	ON	OFF	OFF
+5VALW	5V always on power rail	ON	ON	ON*
+5V	5V power rail	ON	ON	OFF
+5VS	5V switched power rail	ON	OFF	OFF
+12VALW	12V always on power rail	ON	ON	ON*
+12V	12V power rail	ON	ON	OFF
+12VS	12Vswitched power rail on power rail	ON	OFF	OFF
RTCVCC	RTC power	ON	ON	ON

Note : ON* means that this power plane is ON only with AC power available, otherwise it is OFF.

Symbol note:

↓ :means digital ground.

↓ :means analog ground.

@ :means reserved.

Internal PCI Devices

DEVICE	PCI Device ID	IDSEL #
LAN	D8	AD24
Azalia	D27	AD11
PCI-E	D28	AD12
USB1.1/2.0	D29	AD13
PCI to PCI (DMI to PCI)	D30	AD14
AC97 MODEM	D30	AD14
AC97 Audio	D30	AD14
PATA/SATA	D31	AD15
LPC I/F	D31	AD15
SMBUS	D31	AD15

External PCI Devices

DEVICE	PCI Device ID	IDSEL #	REQ/GNT #	PIRQ
Mini-PCI	D4	AD20	0	F
CARD BUS	D6	AD22	2	A B C D

I2C / SMBUS ADDRESSING

DEVICE	HEX	ADDRESS
DDR SO-DIMM 0	A0	10100000
DDR SO-DIMM 1	A2	10100010
CLOCK GENERATOR (EXT.)	D2	11010010

Compal Electronics, Inc.	
Notes List	
Title	Revision
Document Number	Rev
1A-2211	0.6
Date: Thursday, September 09, 2004	Sheet 3 of 48

THIS SHEET OF ENGINEERING DRAWING IS THE PROPRIETARY PROPERTY OF COMPAL ELECTRONICS, INC. AND CONTAINS TRADE SECRET INFORMATION. THIS SHEET MAY NOT BE TRANSFERRED FROM THE CUSTODY OF THE COMPETENT DIVISION OF COMPAL ELECTRONICS, INC. NEITHER THIS SHEET NOR THE INFORMATION IT CONTAINS MAY BE USED BY OR DISCLOSED TO ANY THIRD PARTY WITHOUT PRIOR WRITTEN CONSENT OF COMPAL ELECTRONICS, INC.

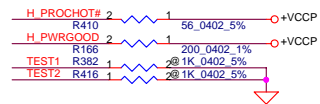
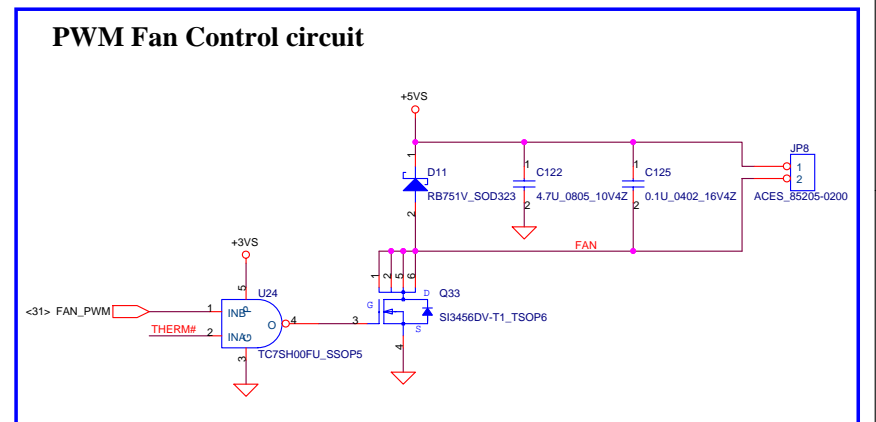
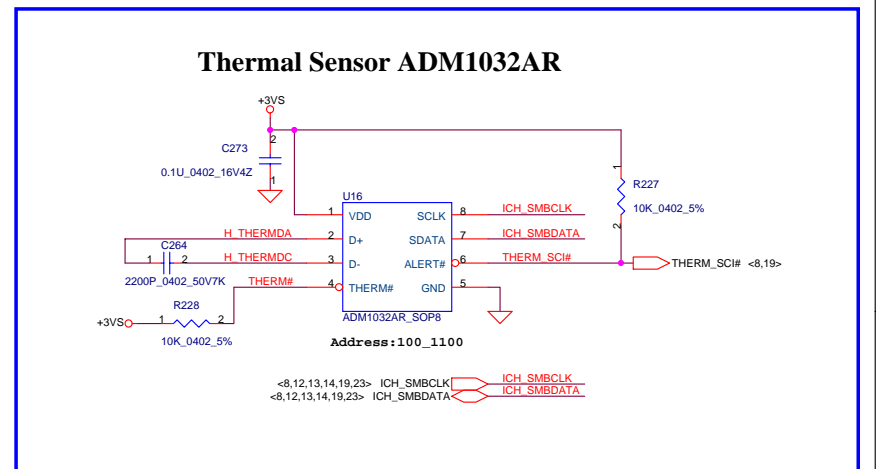
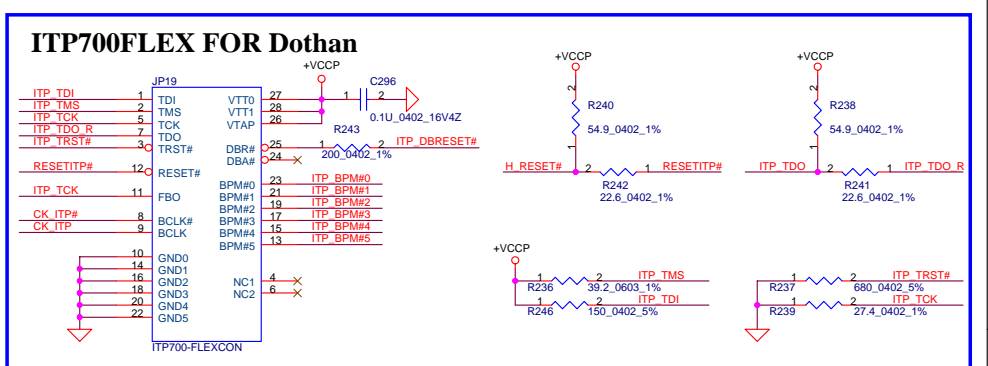
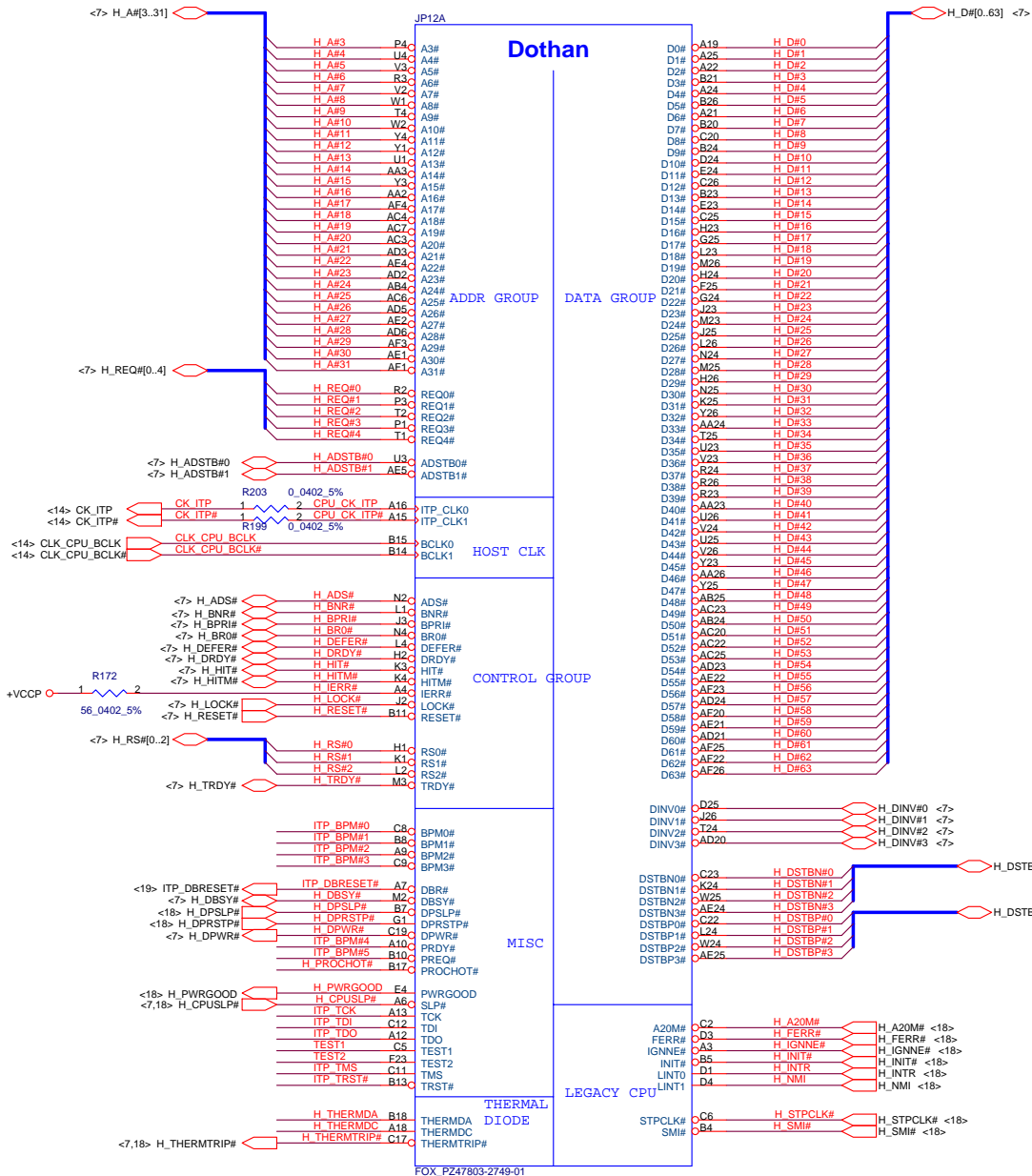

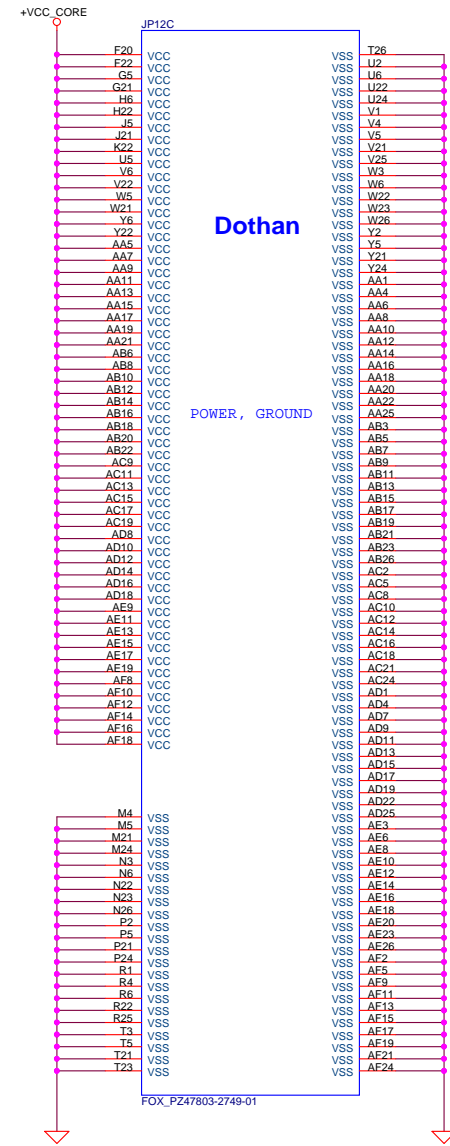
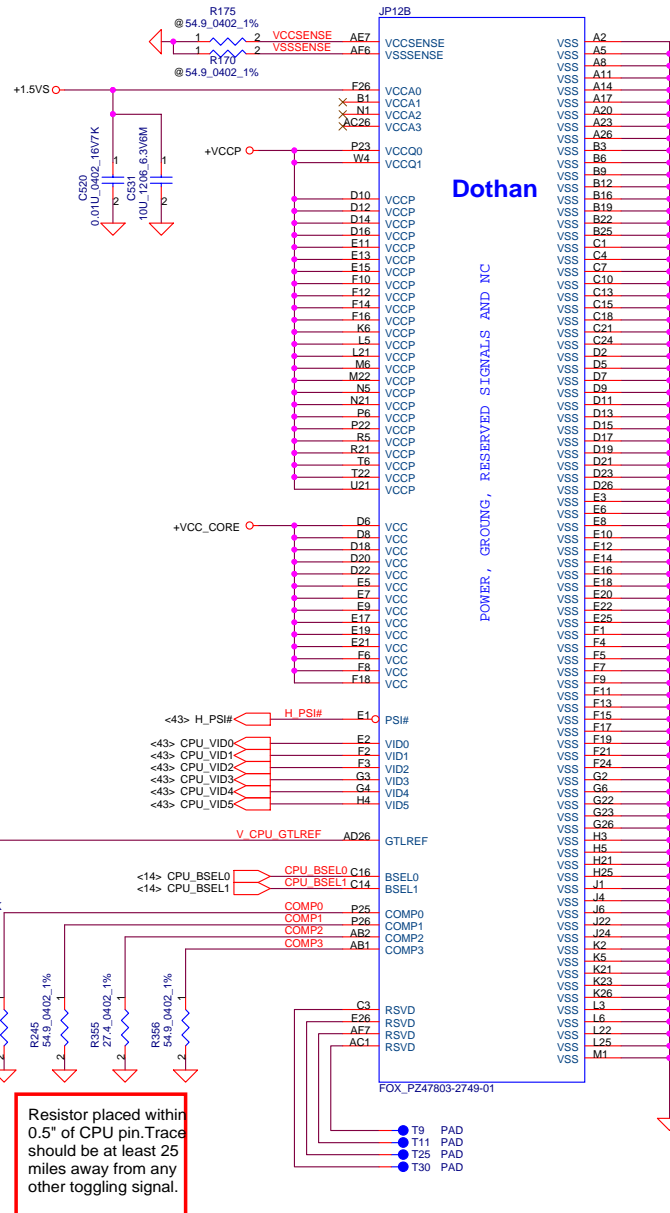

Dothan

Dothan

POWER, GROUND

POWER, GROUND, RESERVED SIGNALS AND NC

- T9 PAD
- T11 PAD
- T25 PAD
- T30 PAD

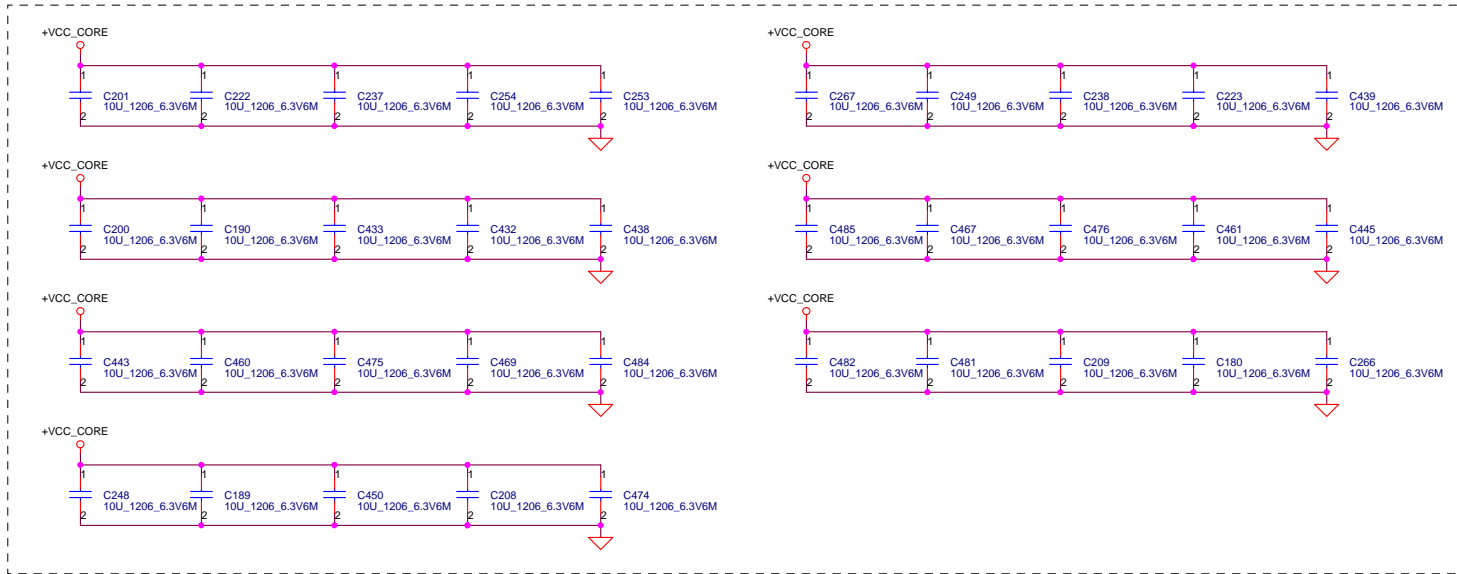

Near VCORE regulator.

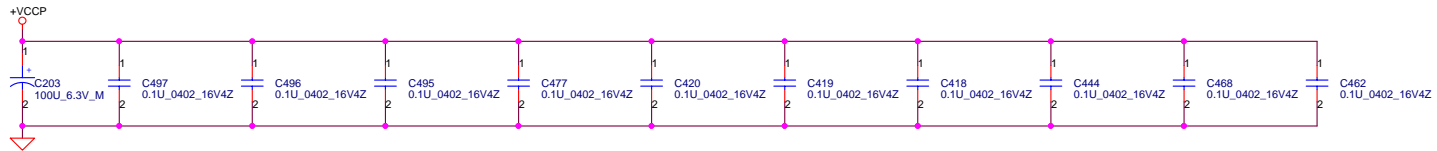
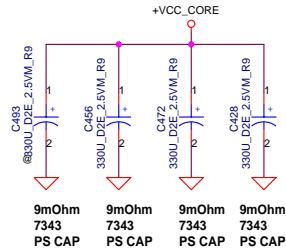

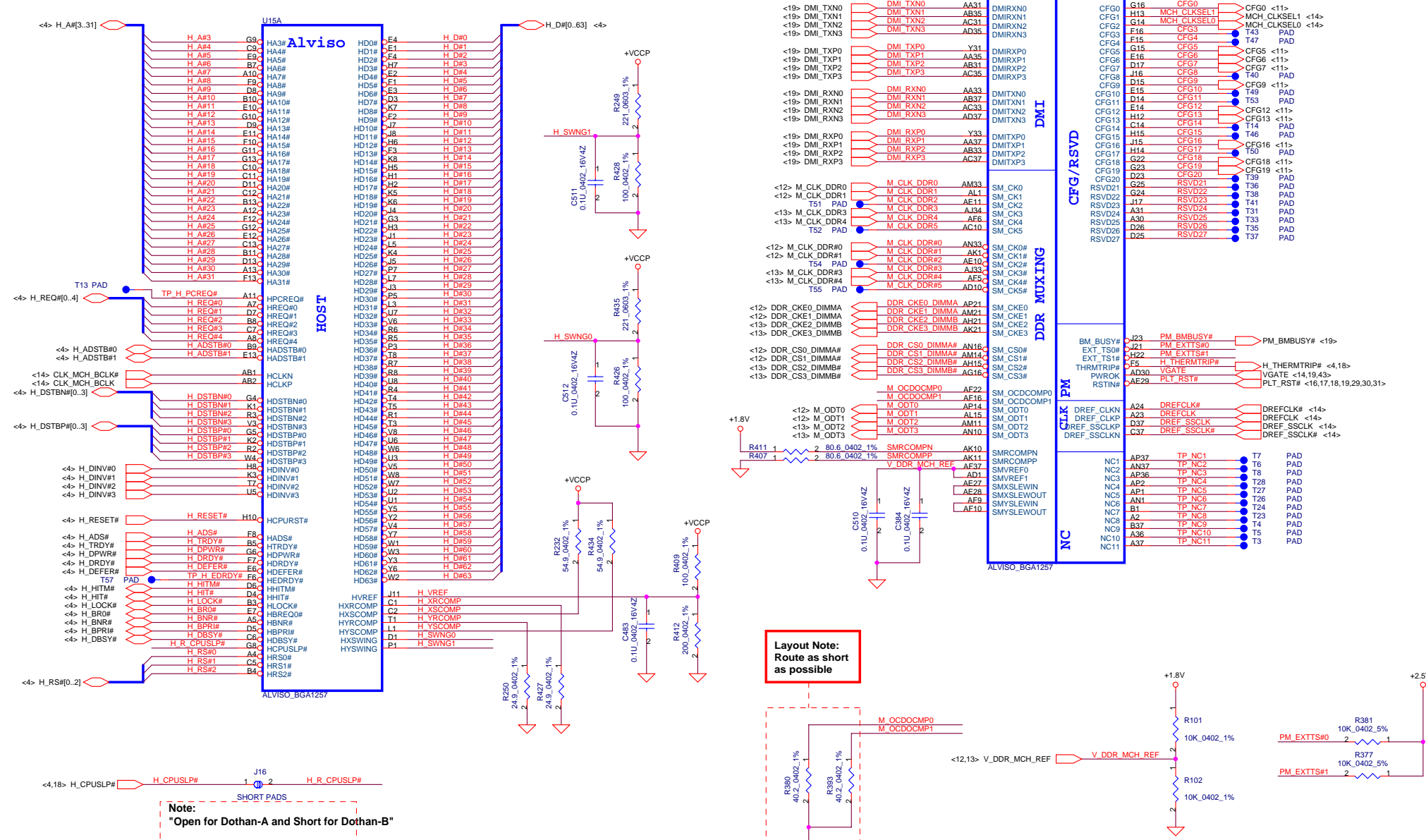

Note:
"Open for Dothan-A and Short for Dothan-B"

Layout Note:
Route as short as possible

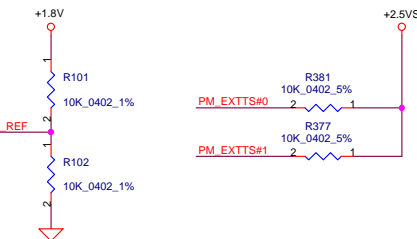

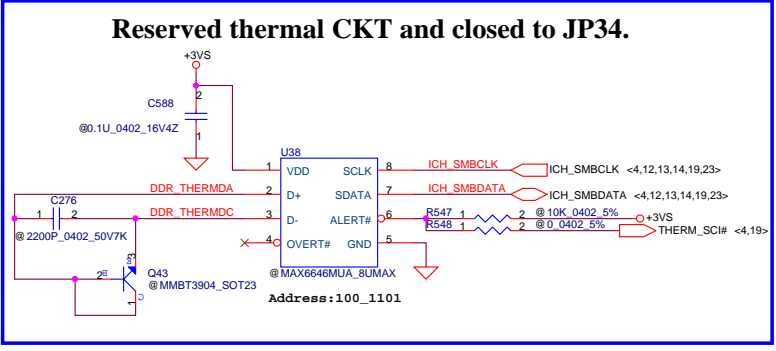
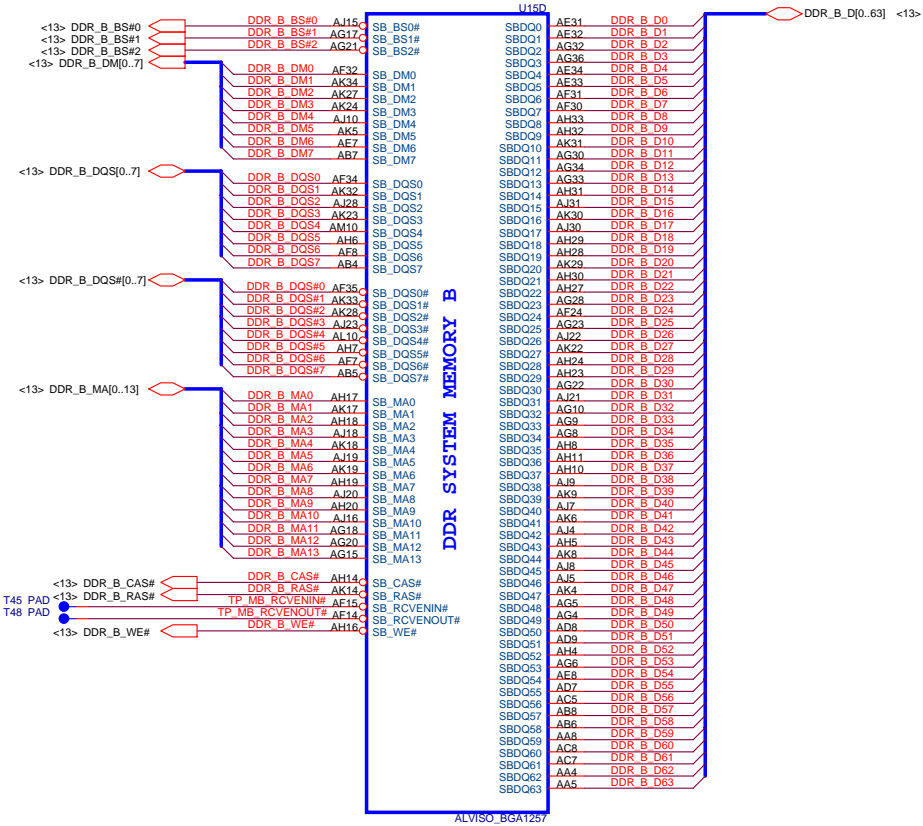
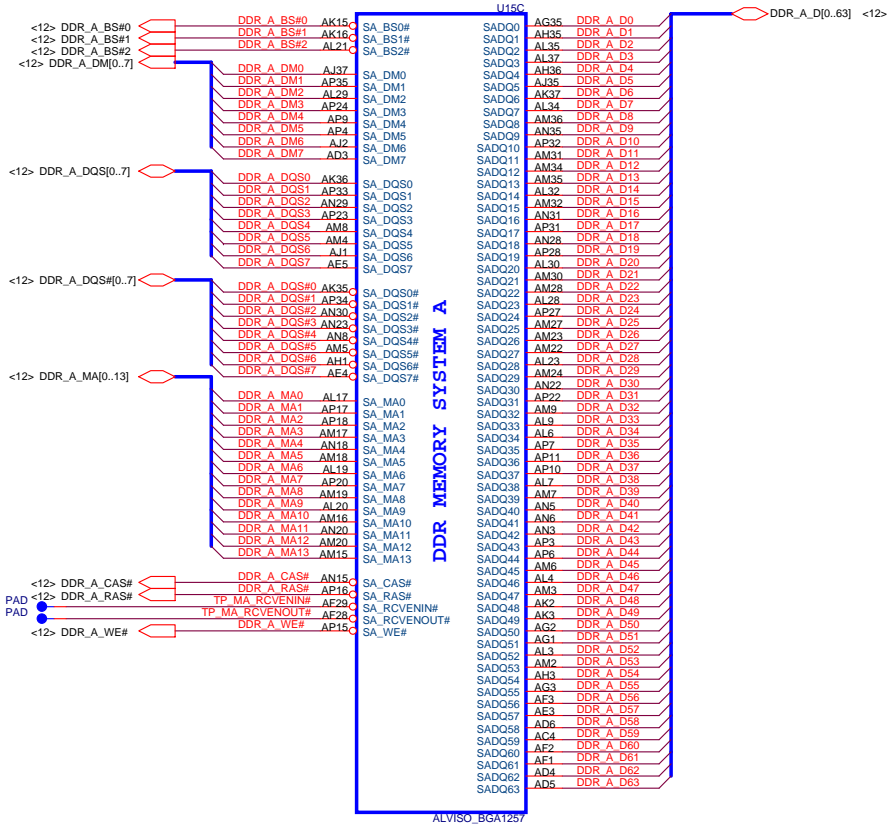

THIS SHEET OF ENGINEERING DRAWING IS THE PROPRIETARY PROPERTY OF COMPAL ELECTRONICS, INC. AND CONTAINS UNCLASSIFIED AND TRADE SECRET INFORMATION. THIS SHEET MAY NOT BE TRANSFERRED FROM THE CUSTODY OF THE COMPETENT DIVISION OF R&D DEPARTMENT EXCEPT AS AUTHORIZED BY COMPAL ELECTRONICS, INC. NEITHER THIS SHEET NOR THE INFORMATION IT CONTAINS MAY BE USED BY OR DISCLOSED TO ANY THIRD PARTY WITHOUT PRIOR WRITTEN CONSENT OF COMPAL ELECTRONICS, INC.

Compal Electronics, Inc.
Alviso (2 of 5)

File: _____
 Revision: _____
 Date: Thursday, September 09, 2004 Sheet 8 of 48

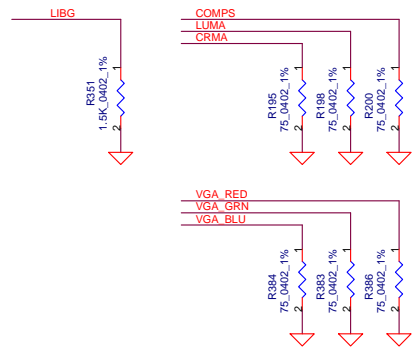
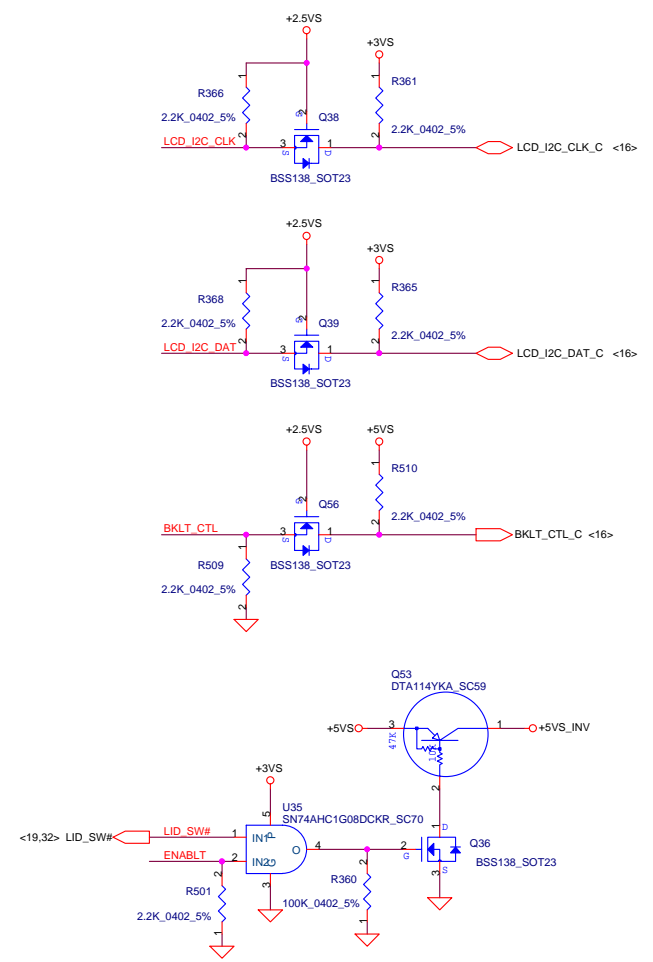
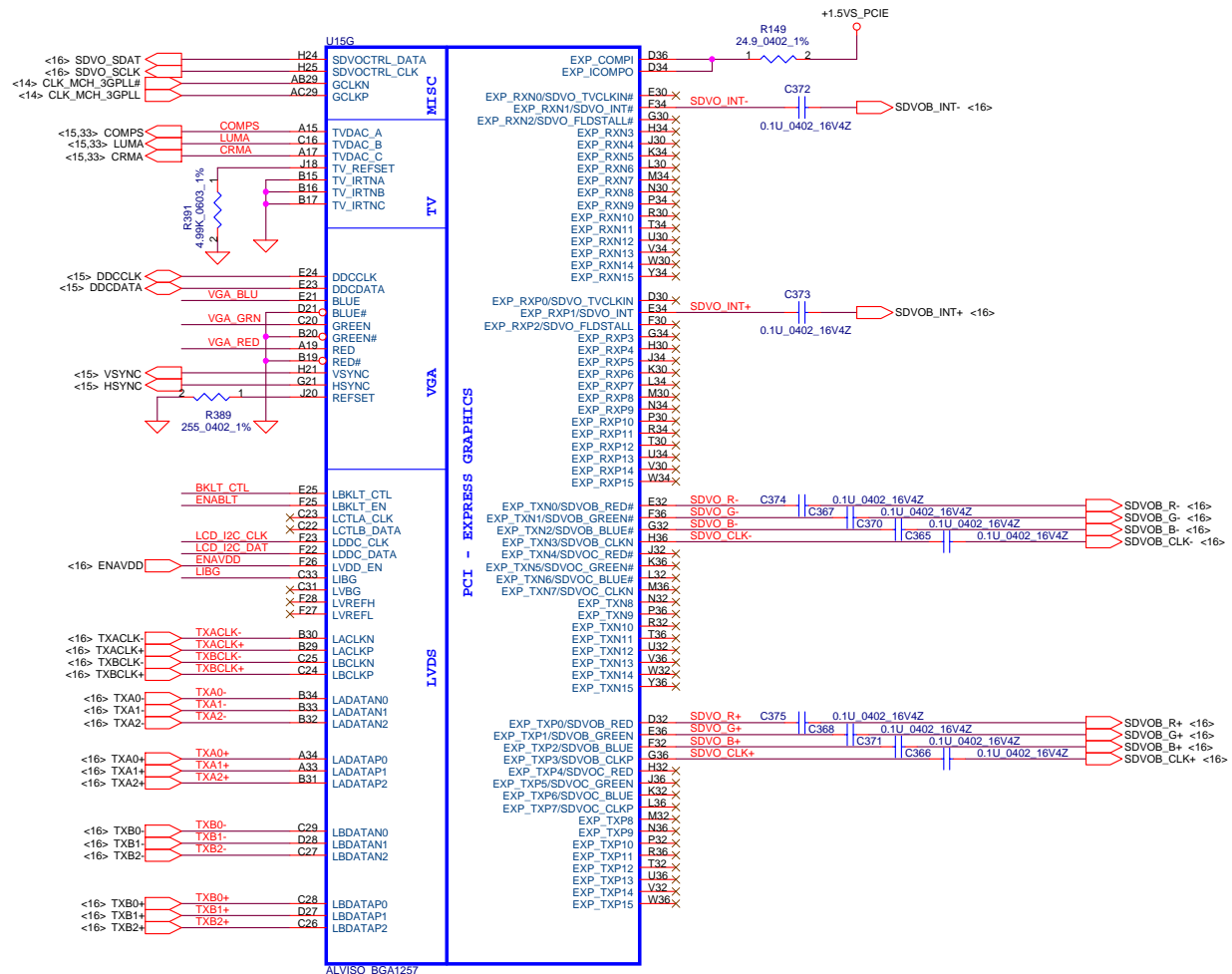

Layout Note:
Place these components as close as possible to Aviso-GM.

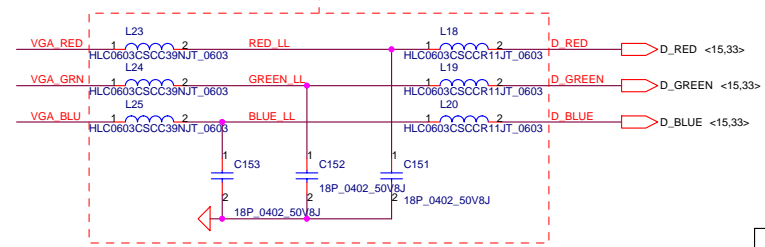

Compal Electronics, Inc.
Aviso (3 of 5)

Title: _____
 Revision: _____
 Date: Thursday, September 09, 2004 Sheet 9 of 48

POWER

POWER

Note : All VCCSM pin shorted internally.

Route VSSATVBG gnd from GMCH to decoupling cap ground lead and then connect to the gnd plane.

Route VSSA3GBG gnd from GMCH to decoupling cap ground lead and then connect to the gnd plane.

CRTDAC: Route caps within 250mil of Alviso. Route FB within 3" of Alviso.

Route VSSACRTDAC gnd from GMCH to decoupling cap ground lead and then connect to the gnd plane.

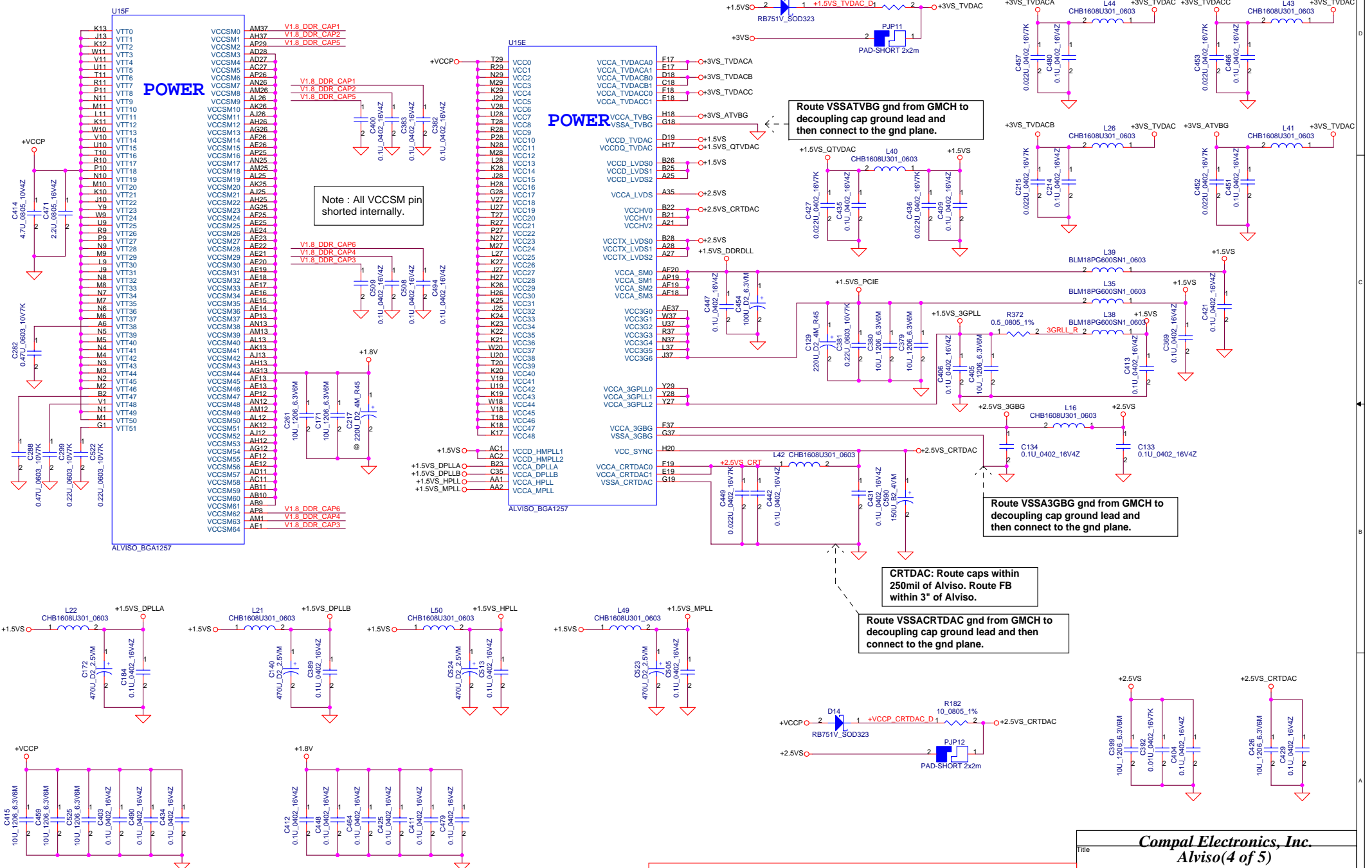

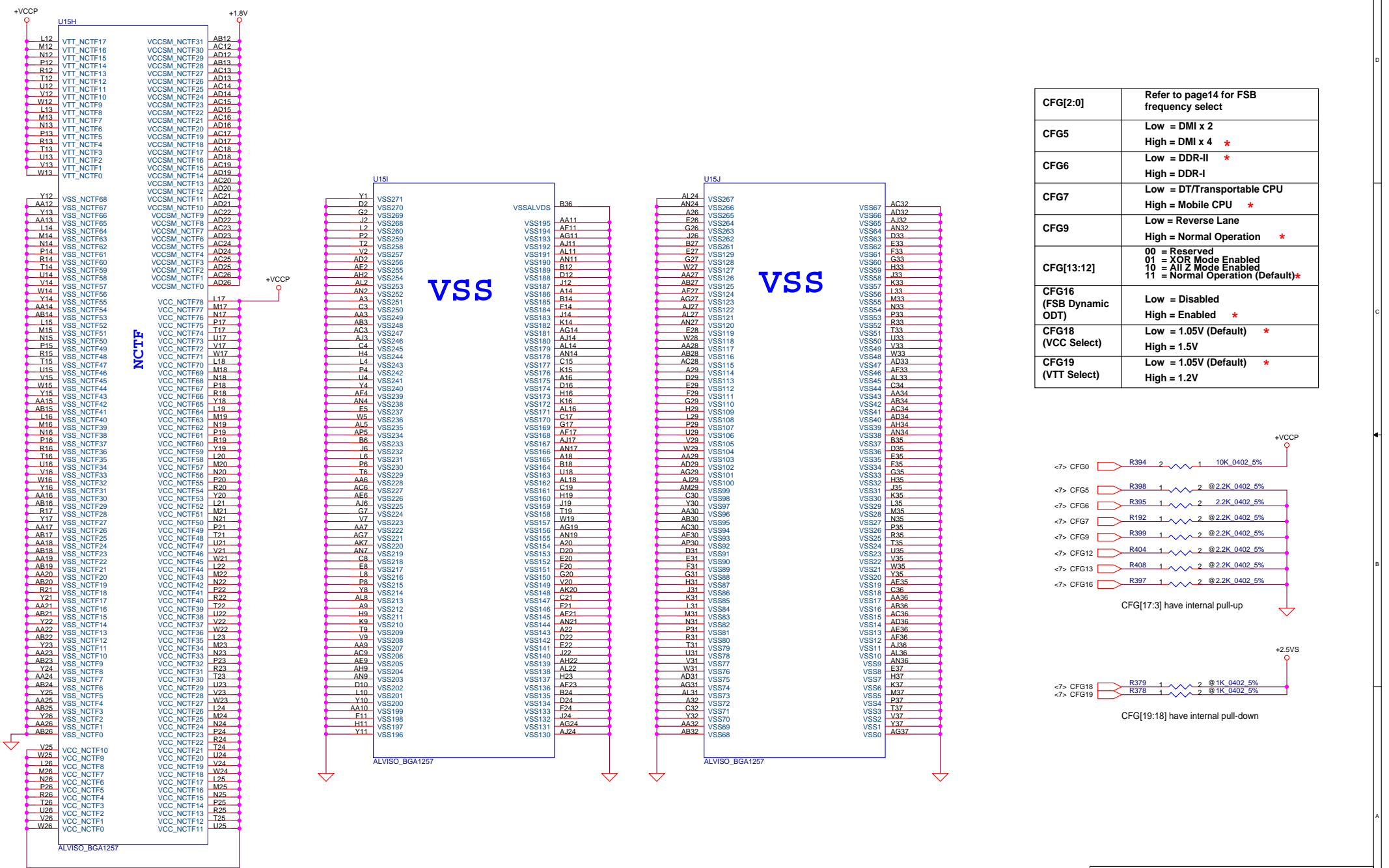

CFG[2:0]	Refer to page14 for FSB frequency select
CFG5	Low = DMI x 2 High = DMI x 4 *
CFG6	Low = DDR-II * High = DDR-I
CFG7	Low = DT/Transportable CPU High = Mobile CPU *
CFG9	Low = Reverse Lane High = Normal Operation *
CFG[13:12]	00 = Reserved 01 = XOR Mode Enabled 10 = All Z Mode Enabled 11 = Normal Operation (Default)*
CFG16 (FSB Dynamic ODT)	Low = Disabled High = Enabled *
CFG18 (VCC Select)	Low = 1.05V (Default) * High = 1.5V
CFG19 (VTT Select)	Low = 1.05V (Default) * High = 1.2V

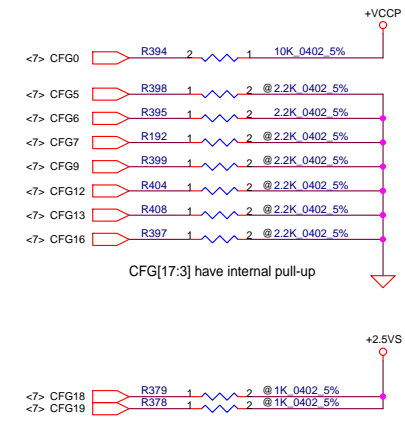

Compal Electronics, Inc.

Alviso(5 of 5)

Title	Revision	Date
	0.6	Thursday, September 09, 2004

Sheet 11 of 48

THIS SHEET OF ENGINEERING DRAWING IS THE PROPRIETARY PROPERTY OF COMPAL ELECTRONICS, INC. AND CONTAINS TRADE SECRET INFORMATION. THIS SHEET MAY NOT BE REPRODUCED OR TRANSMITTED IN ANY FORM OR BY ANY MEANS, ELECTRONIC OR MECHANICAL, INCLUDING PHOTOCOPYING, RECORDING, OR BY ANY INFORMATION STORAGE AND RETRIEVAL SYSTEM, WITHOUT THE WRITTEN CONSENT OF COMPAL ELECTRONICS, INC. DEPARTMENT EXCEPT AS AUTHORIZED BY COMPAL ELECTRONICS, INC. NEITHER THIS SHEET NOR THE INFORMATION IT CONTAINS MAY BE USED BY OR DISCLOSED TO ANY THIRD PARTY WITHOUT PRIOR WRITTEN CONSENT OF COMPAL ELECTRONICS, INC.

- <8> DDR_A_DQS#[0..7]
- <8> DDR_A_D[0..63]
- <8> DDR_A_DM[0..7]
- <8> DDR_A_DQS[0..7]
- <8> DDR_A_MA[0..13]

Layout Note:
Place near JP34

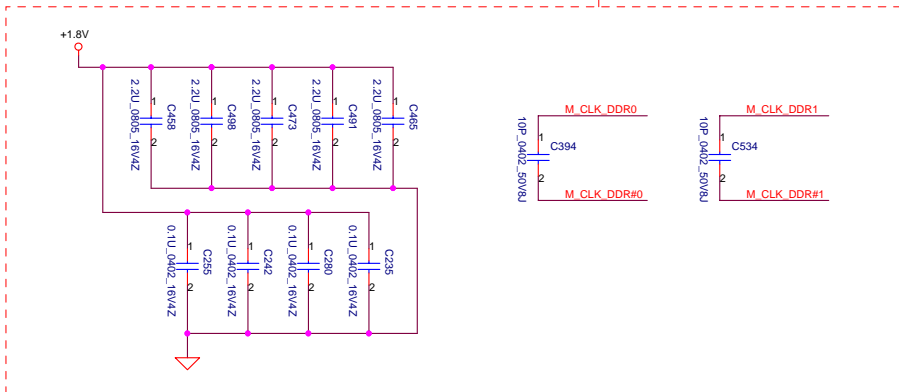

Layout Note:
Place one cap close to every 2 pullup resistors terminated to +0.9V_DDR_VTT

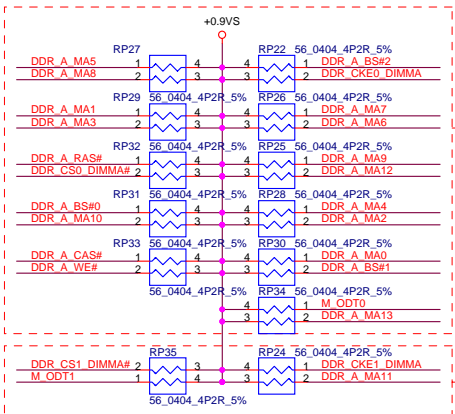
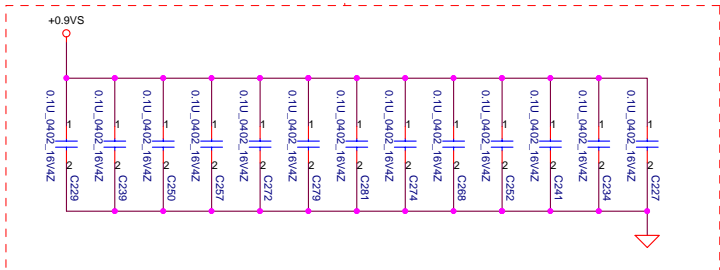

Layout Note:
Place these resistor closely JP34, all trace length <750 mil

Layout Note:
Place these resistor closely JP34, all trace length Max=1.3"

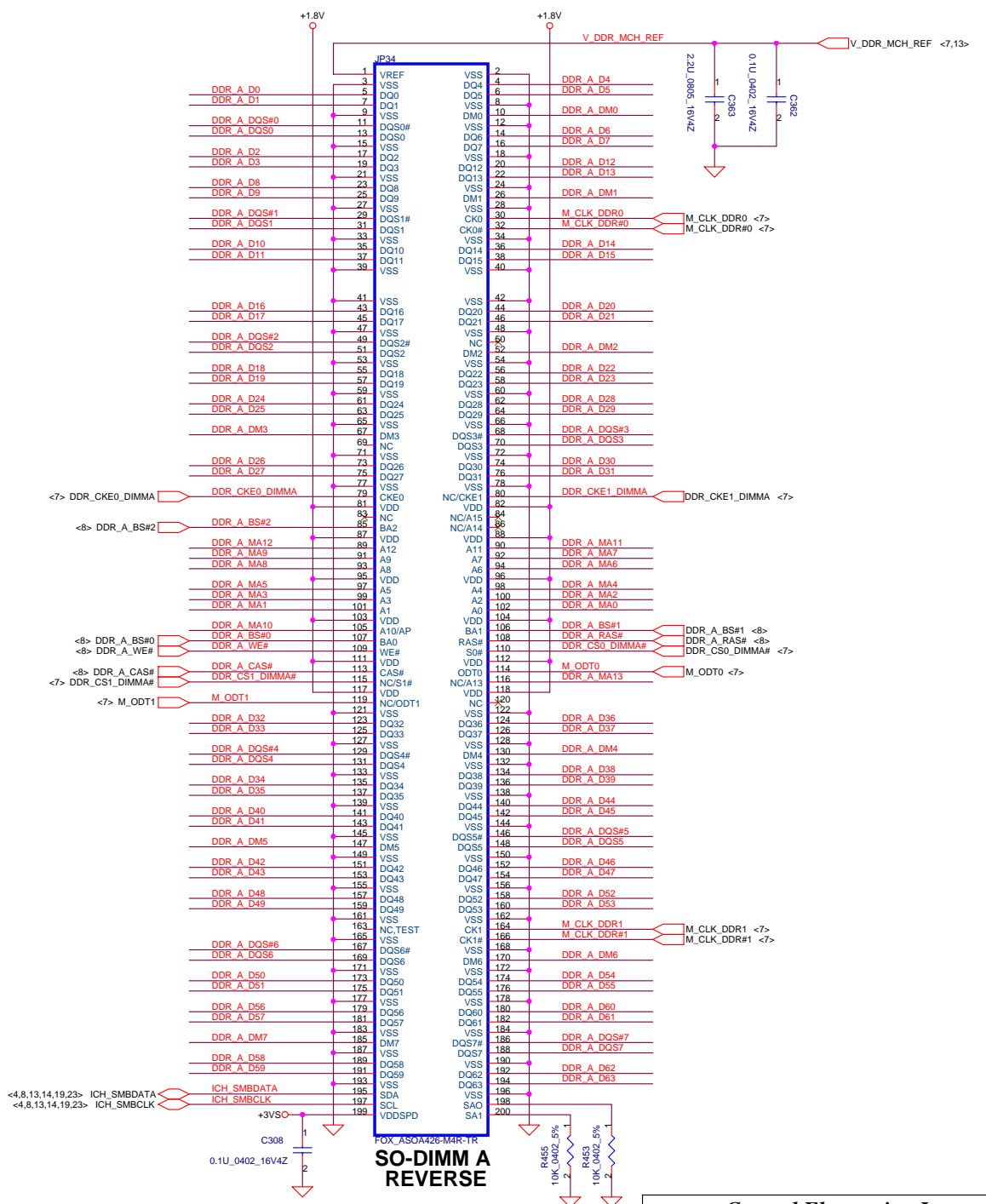

- <8> DDR_B_DQS#[0..7]
- <8> DDR_B_D[0..63]
- <8> DDR_B_DM[0..7]
- <8> DDR_B_DQS[0..7]
- <8> DDR_B_MA[0..13]

Layout Note:
Place near JP10

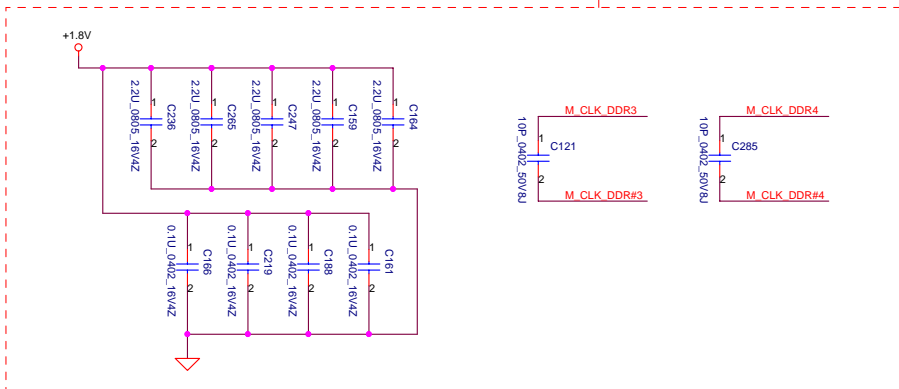

Layout Note:
Place one cap close to every 2 pullup resistors terminated to +0.9V_VDD

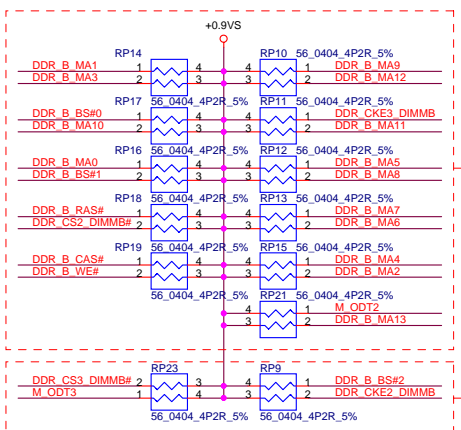
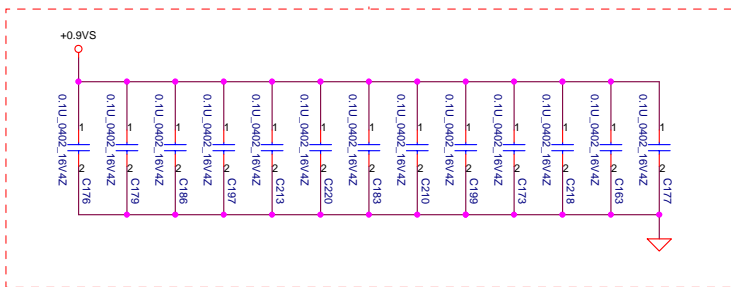

Layout Note:
Place these resistor closely JP10, all trace length <750 mil

Layout Note:
Place these resistor closely JP10, all trace length Max=1.3"

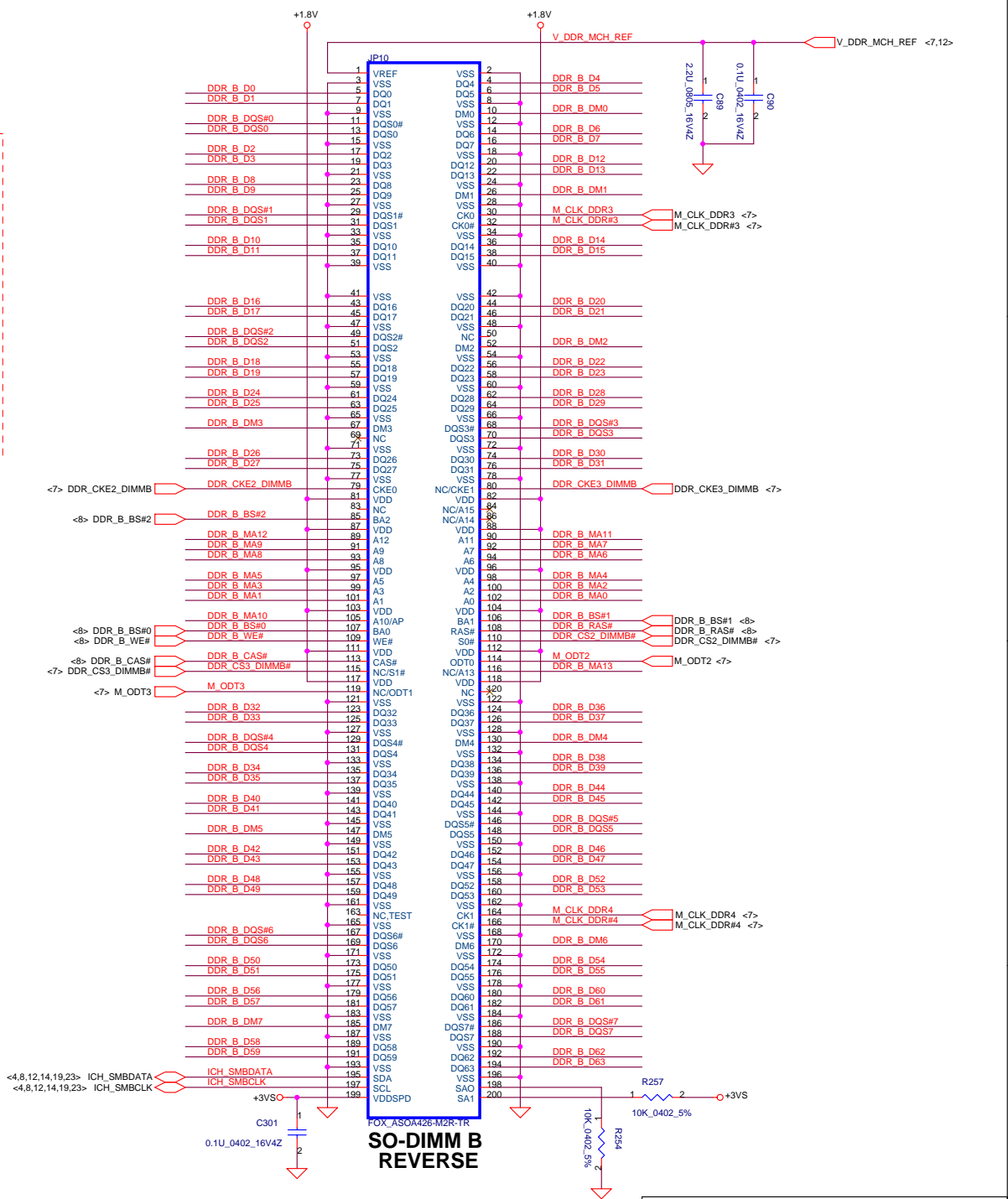

SO-DIMM B REVERSE

Title: **Compal Electronics, Inc.**
DDR11-SODIMM SLOT2
 Date: Thursday, September 09, 2004 Sheet 13 of 48
 Rev: 0.6
 Confidential

THIS SHEET OF ENGINEERING DRAWING IS THE PROPRIETARY PROPERTY OF COMPAL ELECTRONICS, INC. AND CONTAINS CONFIDENTIAL AND TRADE SECRET INFORMATION. THIS SHEET MAY NOT BE TRANSFERRED FROM THE CUSTODY OF THE COMPETENT DEPARTMENT EXCEPT AS AUTHORIZED BY COMPAL ELECTRONICS, INC. NEITHER THIS SHEET NOR THE INFORMATION IT MAY BE USED BY OR DISCLOSED TO ANY THIRD PARTY WITHOUT PRIOR WRITTEN CONSENT OF COMPAL ELECTRONICS, INC.

FSC	FSB	FSA	CPU	SRC	PCI
CLKSEL0	CLKSEL1	CLKSEL2	MHz	MHz	MHz
0	0	1	133	100	33.3
1	0	1	100	100	33.3

CPU Type	CLK-Ra	CLK-Rb	CLK-Rc	CLK-Rd	CLK-Re	CLK-Rf
Dothan-A PSB400	OPEN	1K Ohm	OPEN	OPEN	0 Ohm	OPEN
Dothan-A PSB533	OPEN	OPEN	0 Ohm	OPEN	0 Ohm	OPEN
Dothan-B	SHORT	1K Ohm	OPEN	0 Ohm	OPEN	1K Ohm

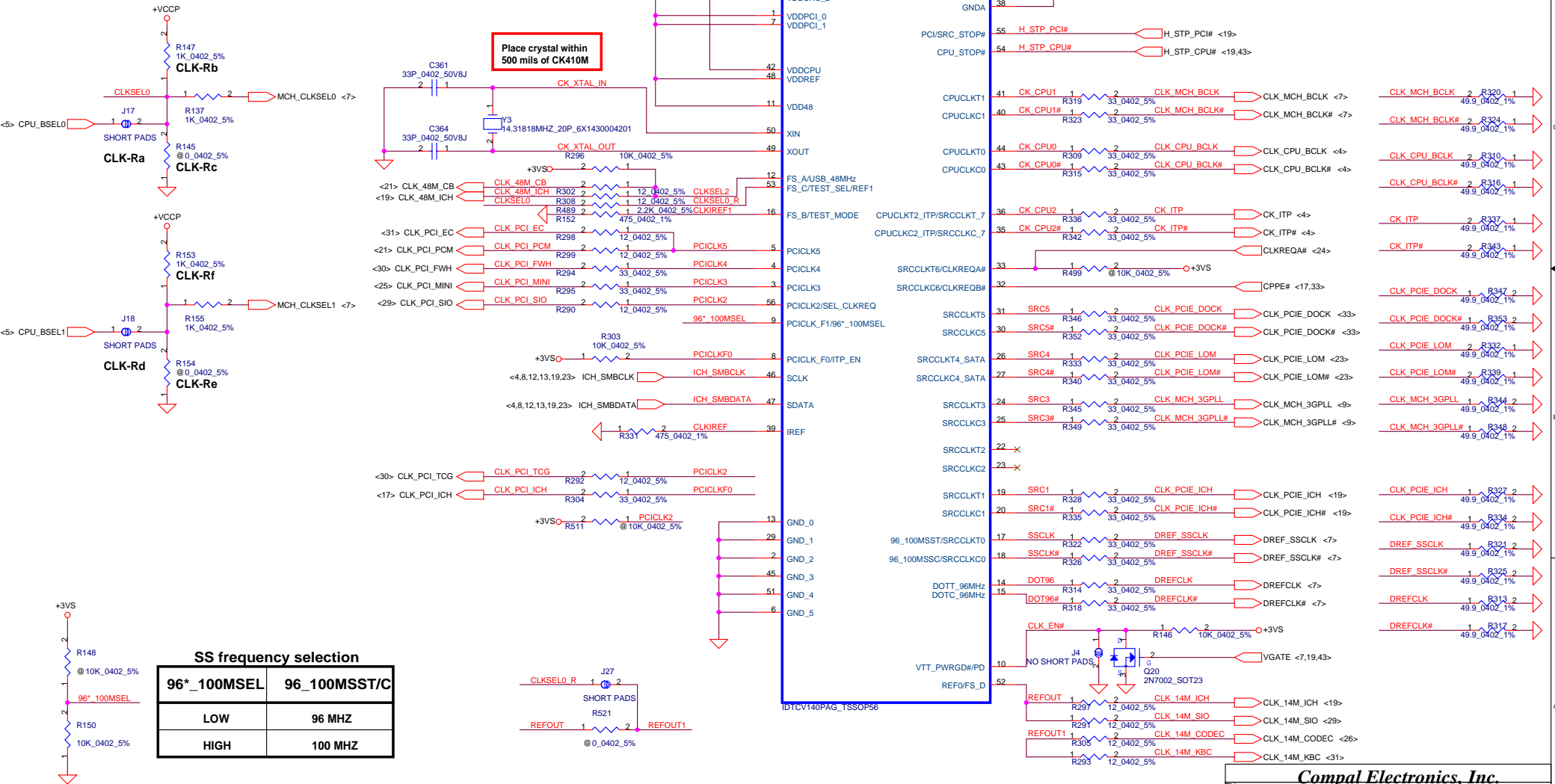

SS frequency selection

96*_100MSEL	96_100MSST/C
LOW	96 MHZ
HIGH	100 MHZ

Compal Electronics, Inc.
Clock Generator

THIS SHEET OF ENGINEERING DRAWING IS THE PROPRIETARY PROPERTY OF COMPAL ELECTRONICS, INC. AND CONTAINS TRADE SECRET INFORMATION. THIS SHEET MAY NOT BE TRANSFERRED FROM THE CUSTODY OF THE COMPETENT DESIGN DEPARTMENT EXCEPT AS AUTHORIZED BY COMPAL ELECTRONICS, INC. NEITHER THIS SHEET NOR THE INFORMATION IT CONTAINS MAY BE USED BY OR DISCLOSED TO ANY THIRD PARTY WITHOUT PRIOR WRITTEN CONSENT OF COMPAL ELECTRONICS, INC.

Revision Number: **14-2211**
Date: Thursday, September 09, 2004 Sheet 14 of 48 Rev 0.6

CRT Connector

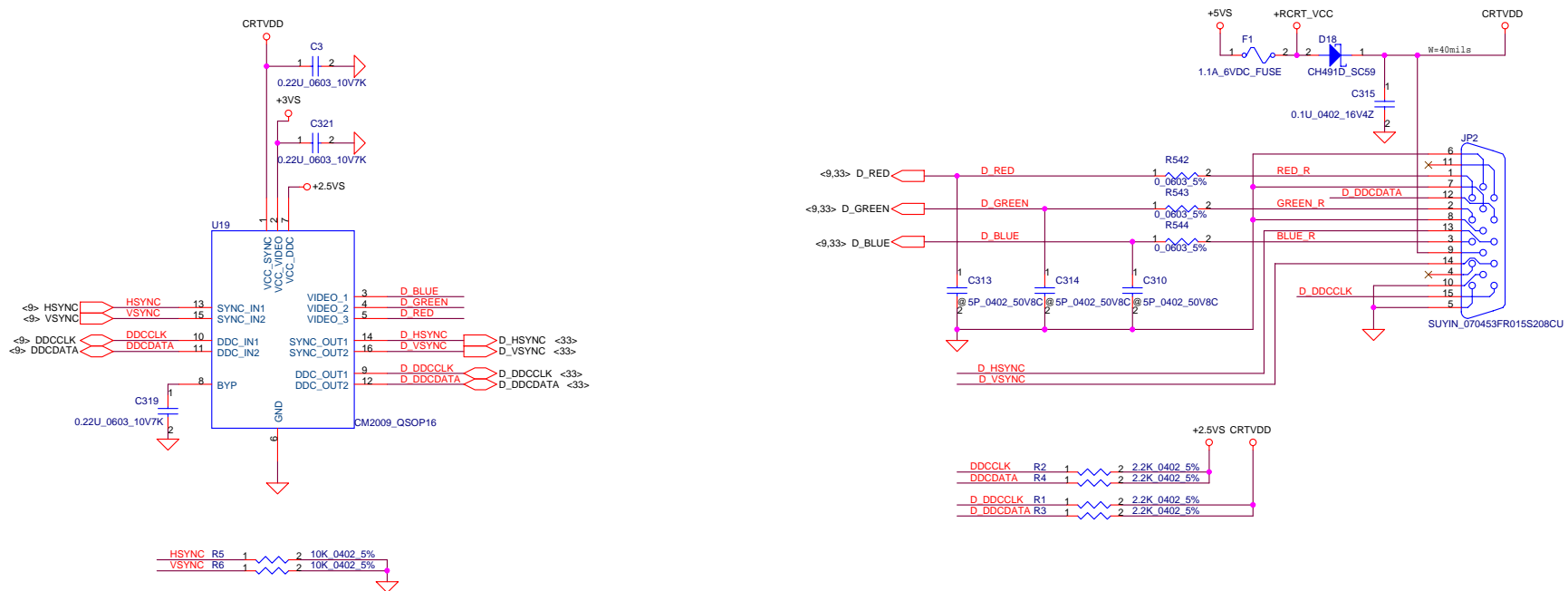

TV-Out Connector

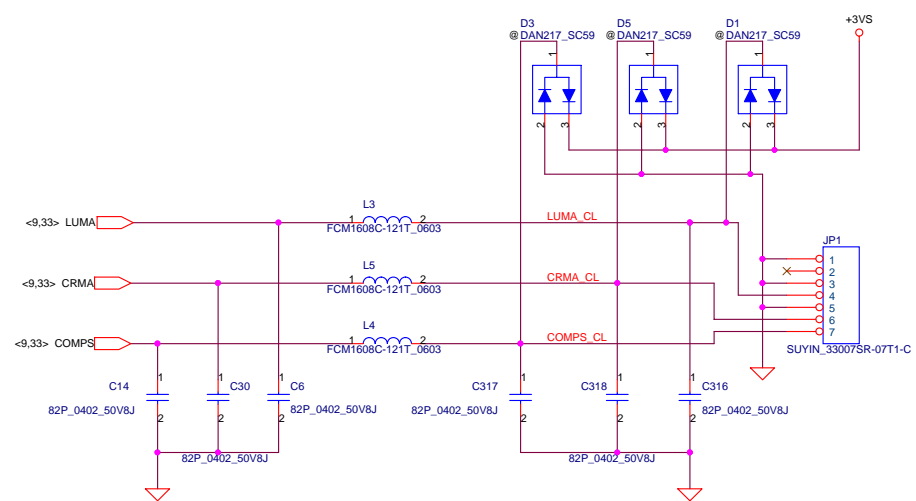

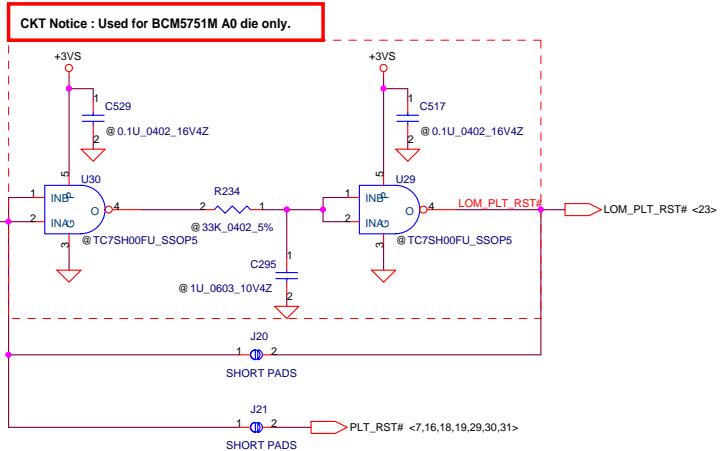
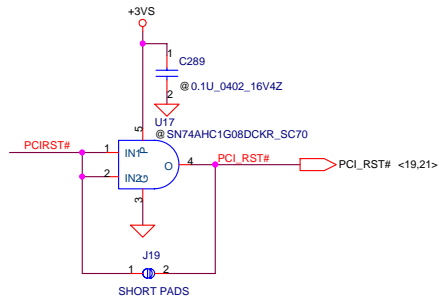
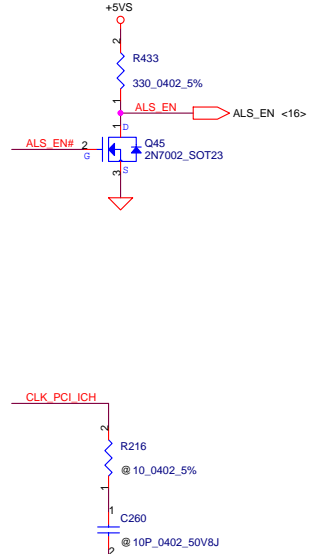
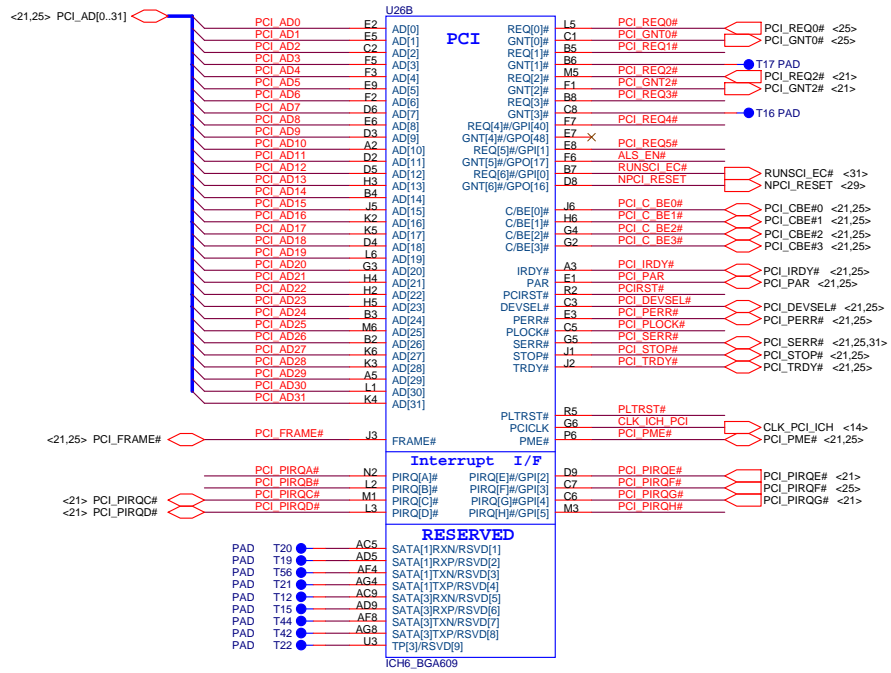
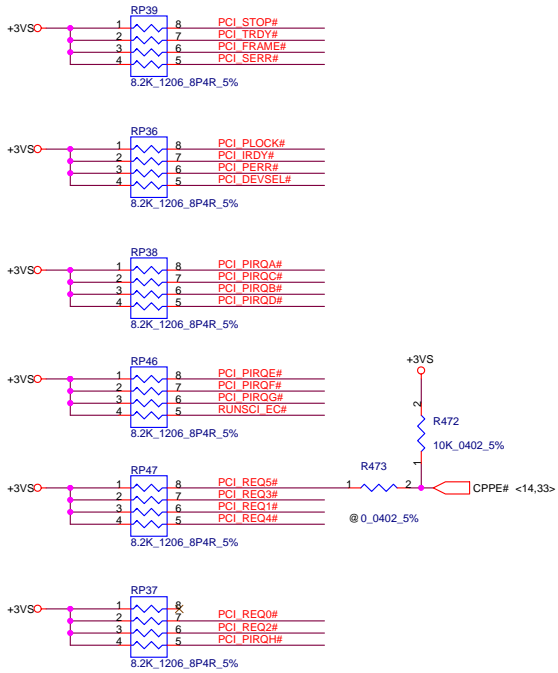

CKT Notice : Used for BCM5751M A0 die only.

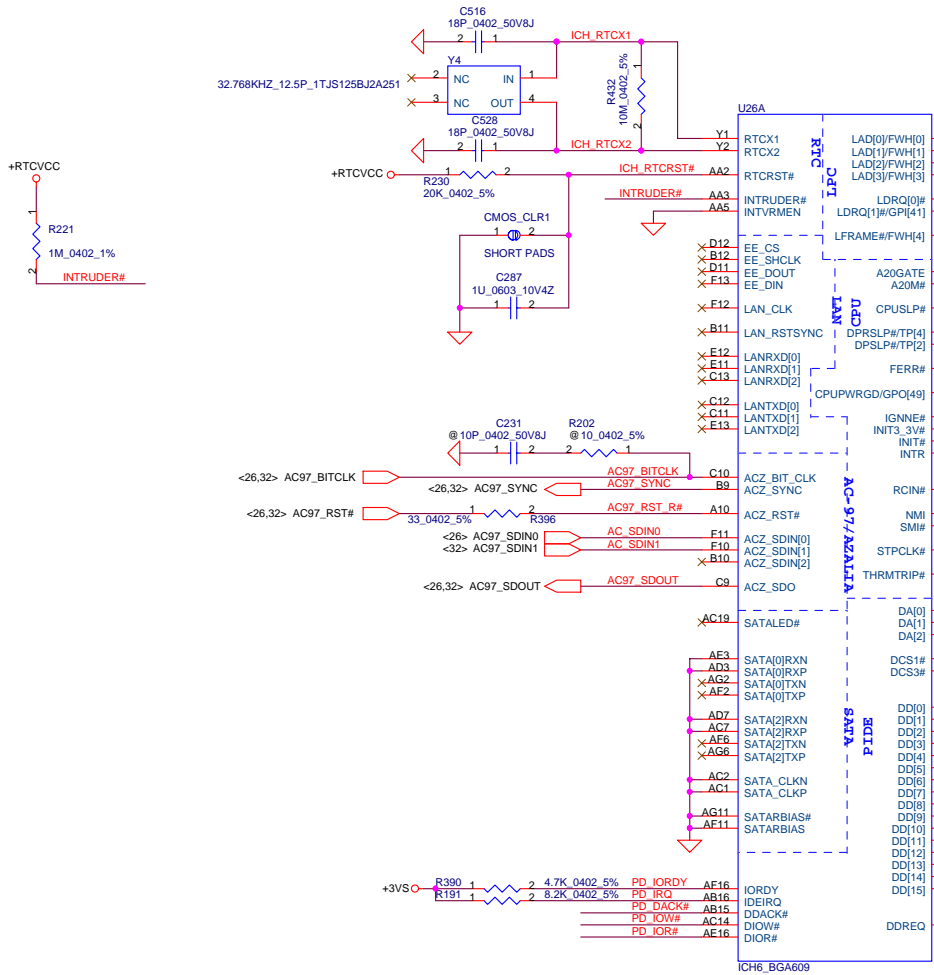

CPU Type	J22	R160
Dothan-A	OPEN	0 Ohm
Dothan-B	SHORT	OPEN

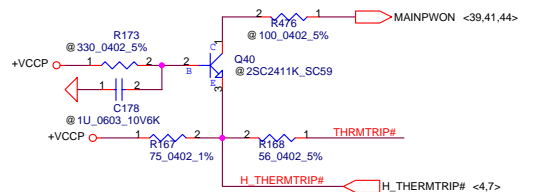
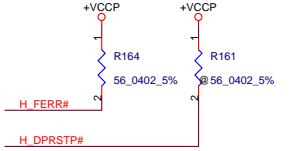

PATA CONN

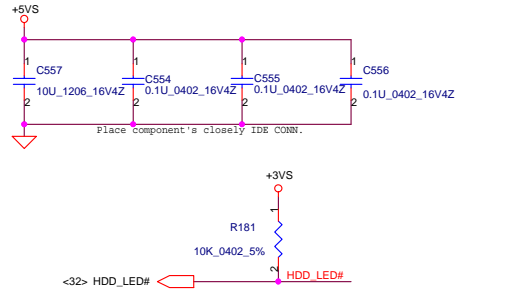
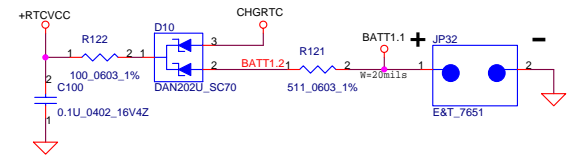
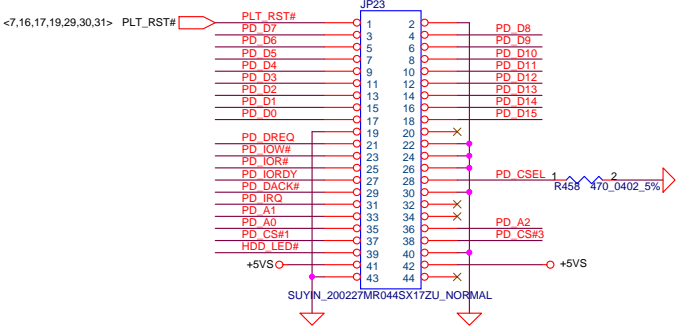

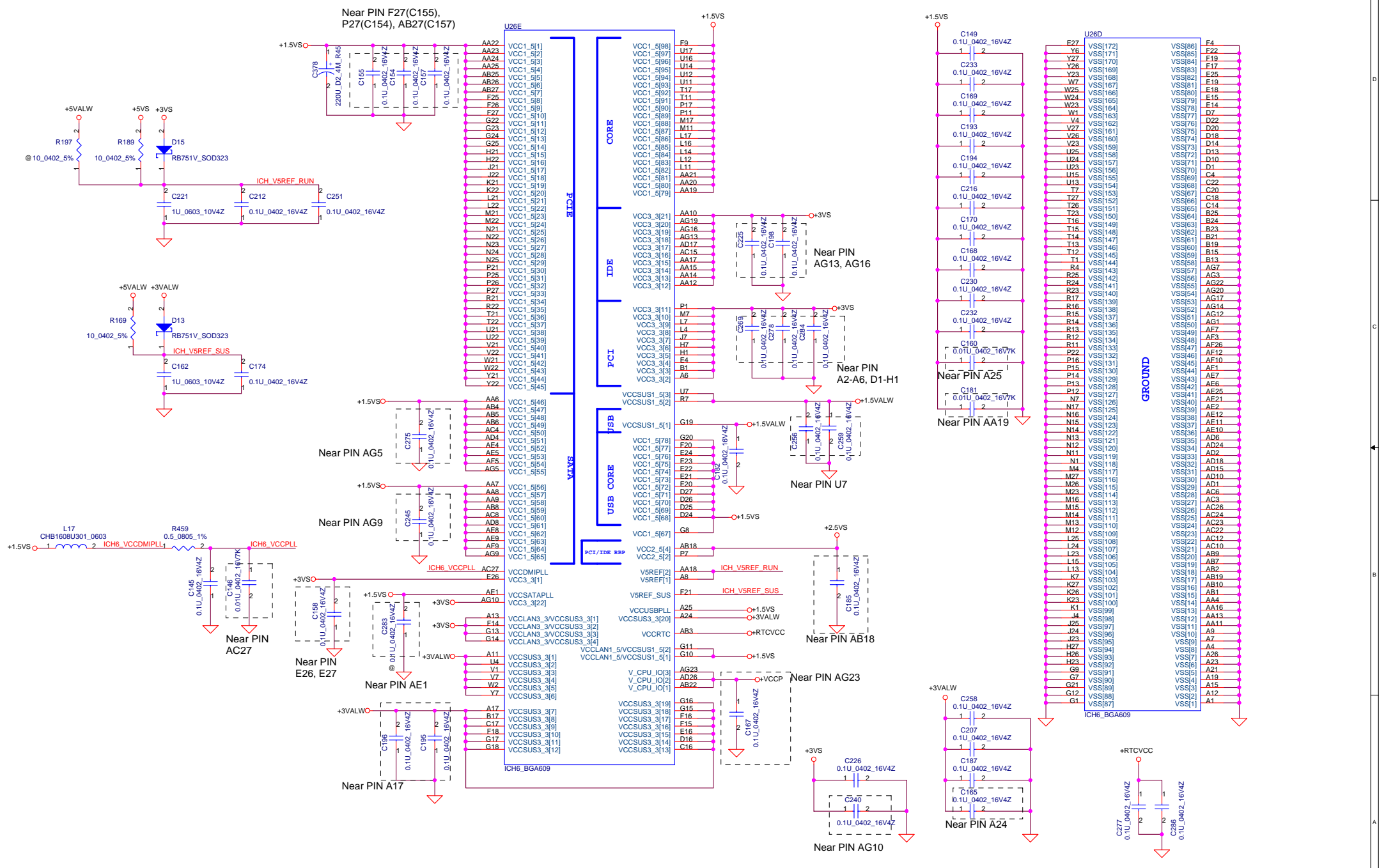

THIS SHEET OF ENGINEERING DRAWING IS THE PROPRIETARY PROPERTY OF COMPAL ELECTRONICS, INC. AND CONTAINS TRADE SECRET INFORMATION. THIS SHEET MAY NOT BE TRANSFERRED FROM THE CUSTODY OF THE COMPETENT DEPARTMENT EXCEPT AS AUTHORIZED BY COMPAL ELECTRONICS, INC. NEITHER THIS SHEET NOR THE INFORMATION IT CONTAINS MAY BE USED BY OR DISCLOSED TO ANY THIRD PARTY WITHOUT PRIOR WRITTEN CONSENT OF COMPAL ELECTRONICS, INC.

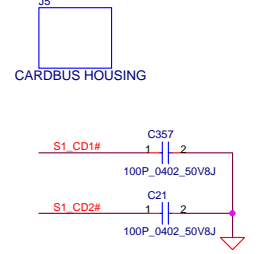
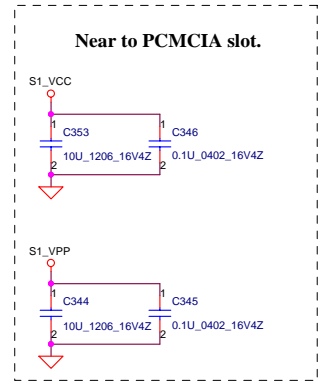
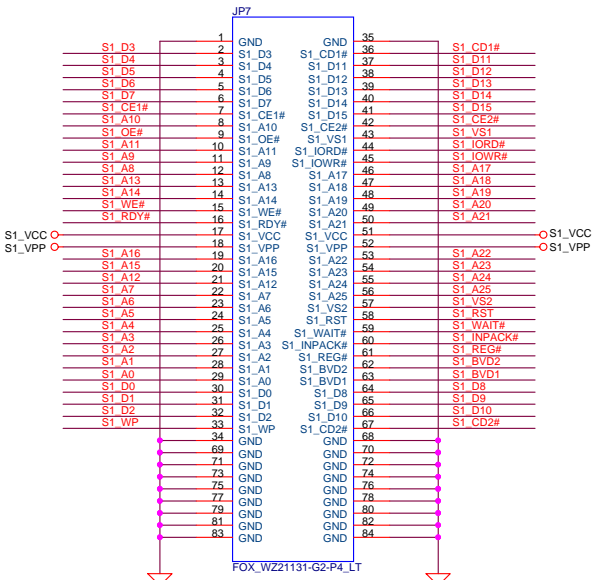
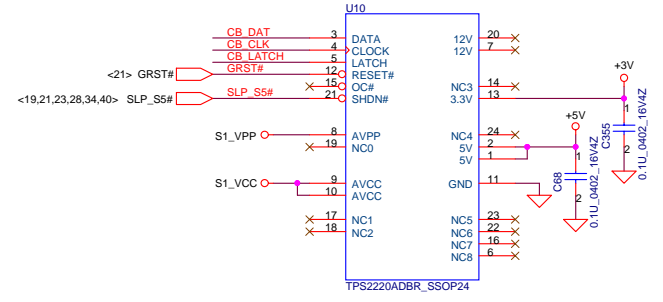
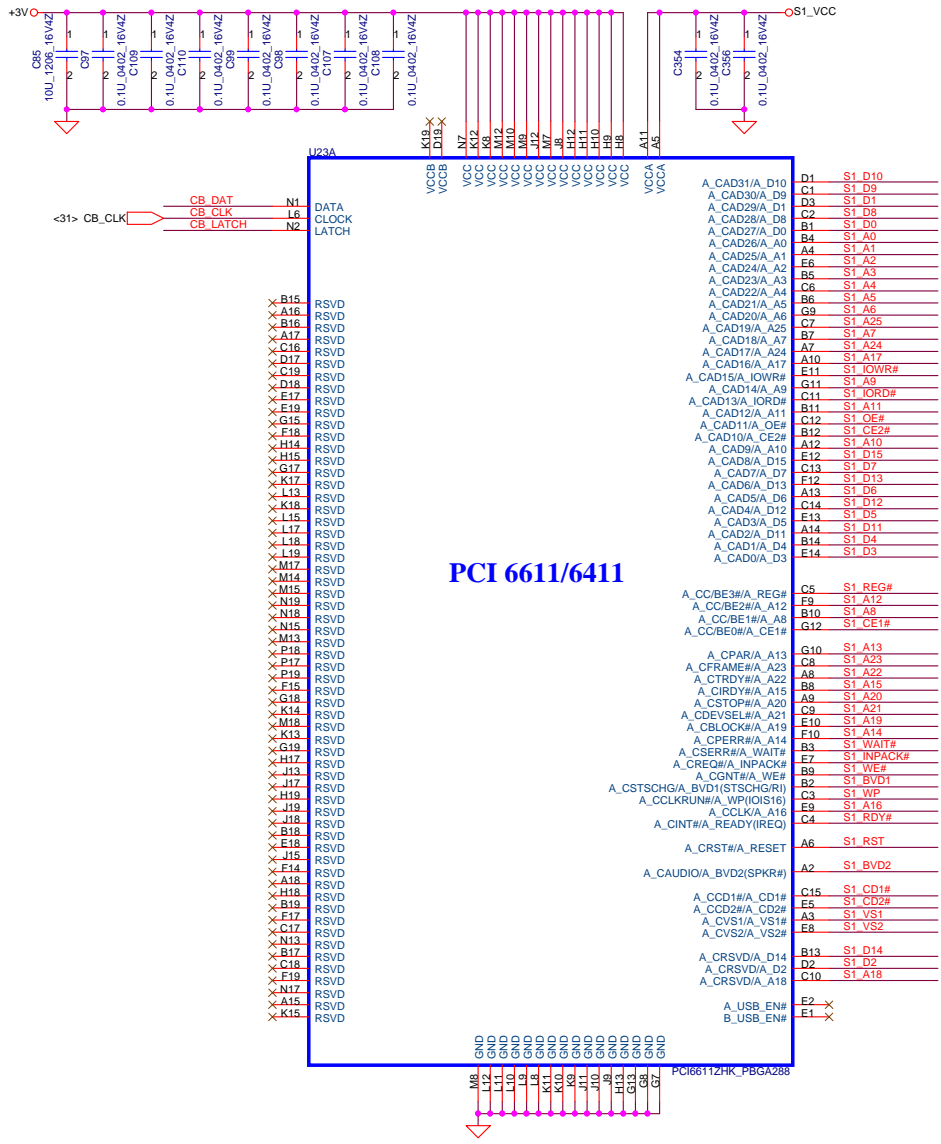

THIS SHEET OF ENGINEERING DRAWING IS THE PROPRIETARY PROPERTY OF COMPAL ELECTRONICS, INC. AND CONTAINS CONFIDENTIAL AND TRADE SECRET INFORMATION. THIS SHEET MAY NOT BE TRANSFERRED FROM THE CUSTODY OF THE COMPETENT DIVISION OR DEPARTMENT EXCEPT AS AUTHORIZED BY COMPAL ELECTRONICS, INC. NEITHER THIS SHEET NOR THE INFORMATION IT CONTAINS MAY BE USED BY OR DISCLOSED TO ANY THIRD PARTY WITHOUT PRIOR WRITTEN CONSENT OF COMPAL ELECTRONICS, INC.

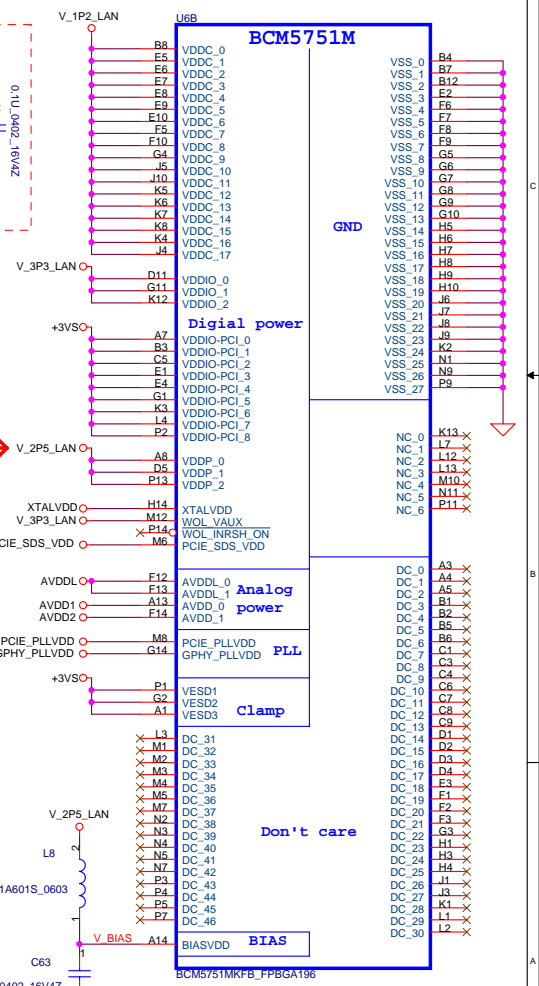
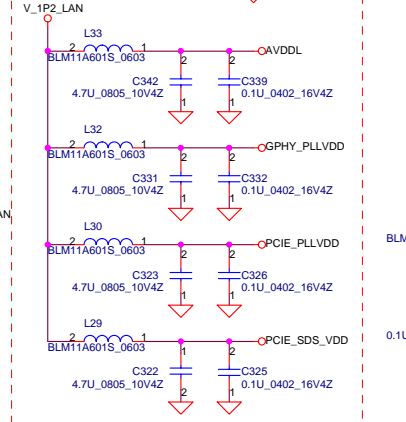
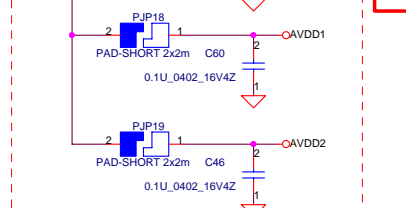
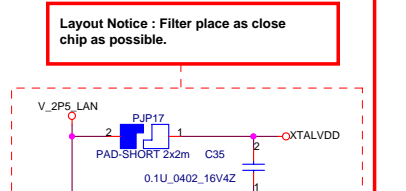
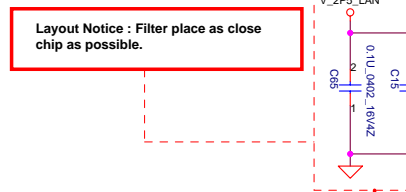
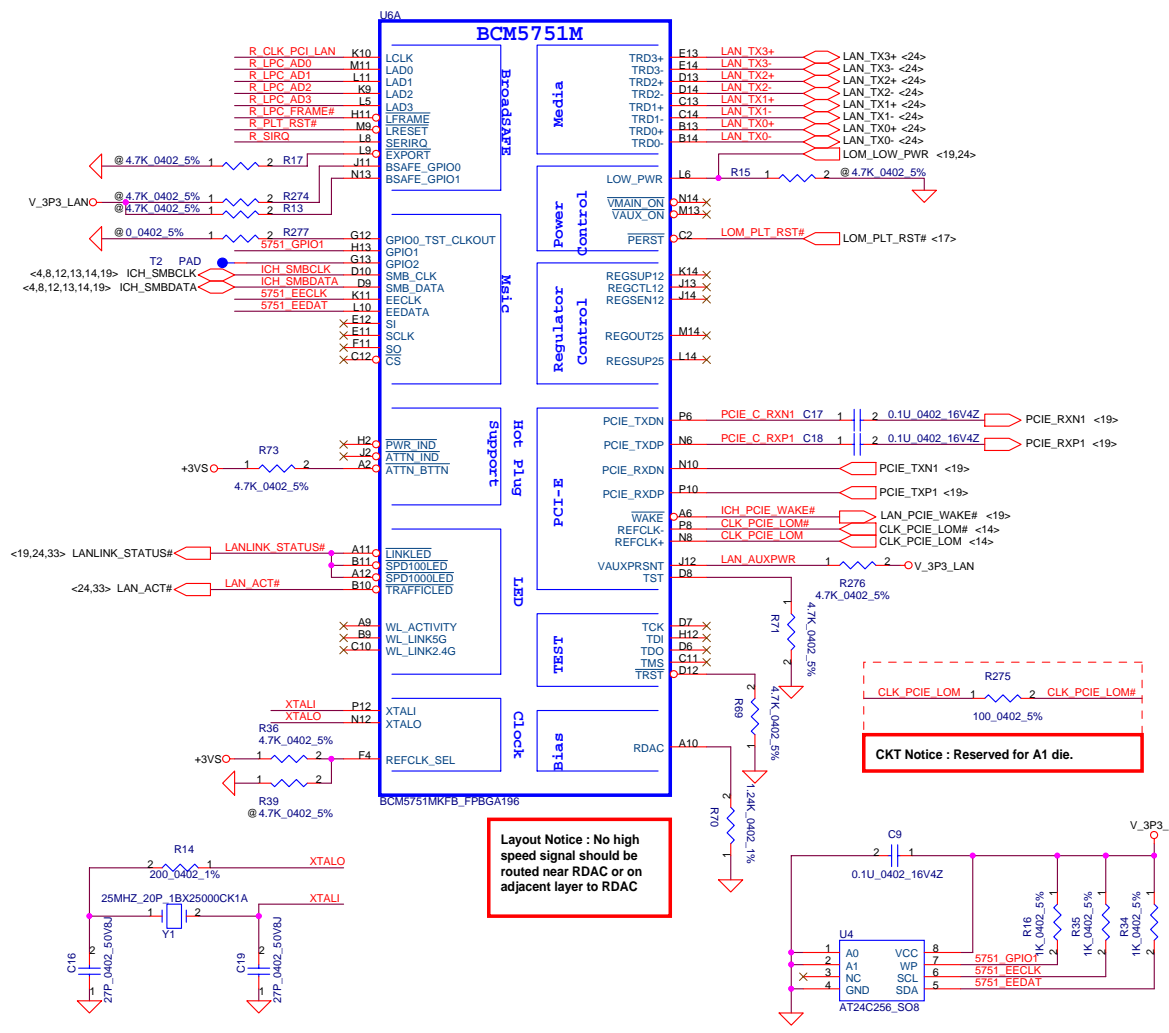
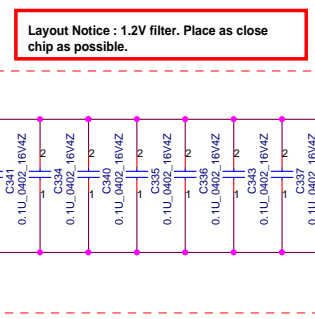
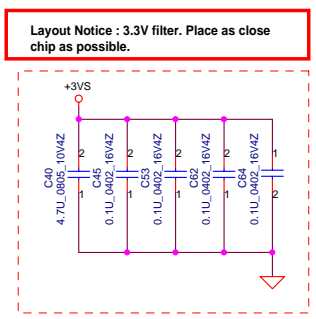
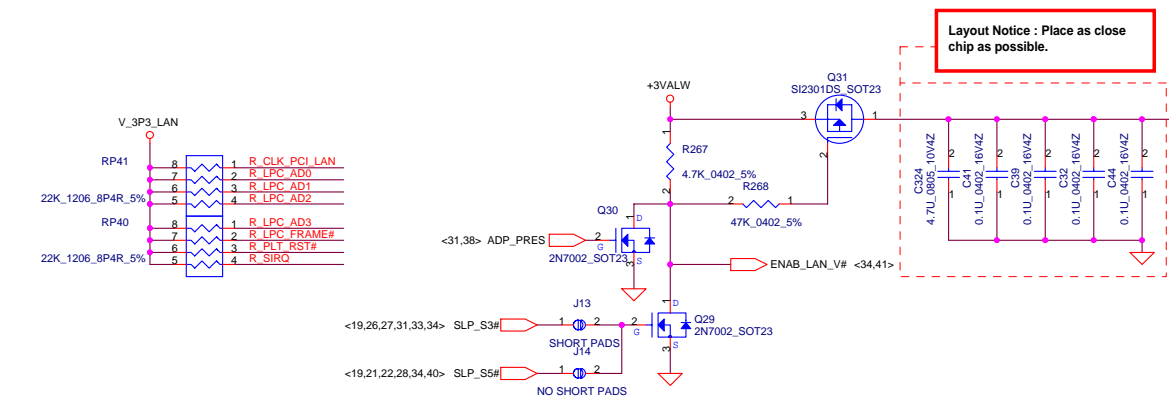

CKT Notice : Reserved for A1 die.

Layout Notice : No high speed signal should be routed near RDAC or on adjacent layer to RDAC

Layout Notice : Place as close chip as possible.

Layout Notice : 3.3V filter. Place as close chip as possible.

Layout Notice : 1.2V filter. Place as close chip as possible.

Layout Notice : Filter place as close chip as possible.

Layout Notice : Filter place as close chip as possible.

Layout Notice : Filter place as close chip as possible.

RJ-45 CONN.

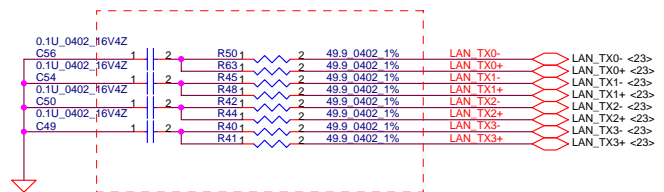
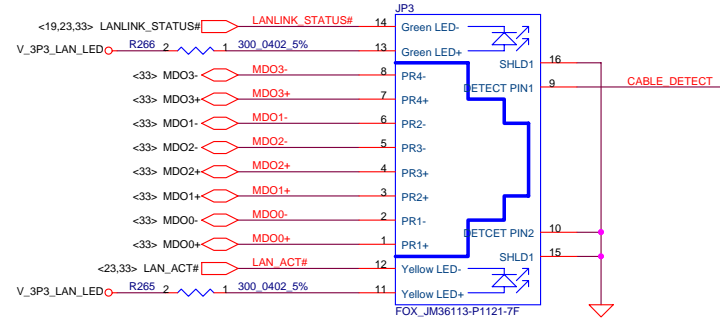
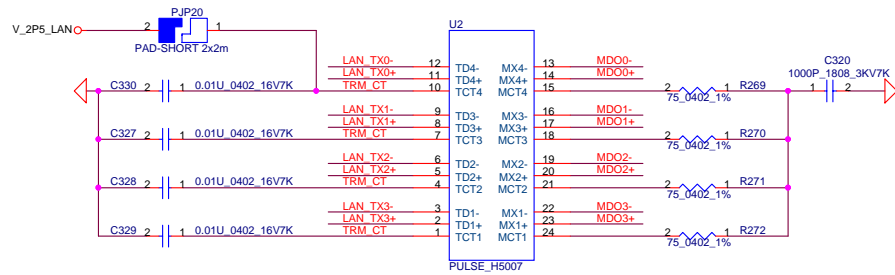

Layout Notice : Place termination as close as BCM5751M as possible

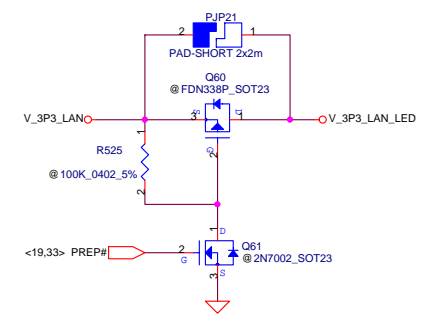

RJ-11 CONN.

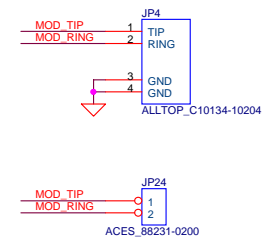
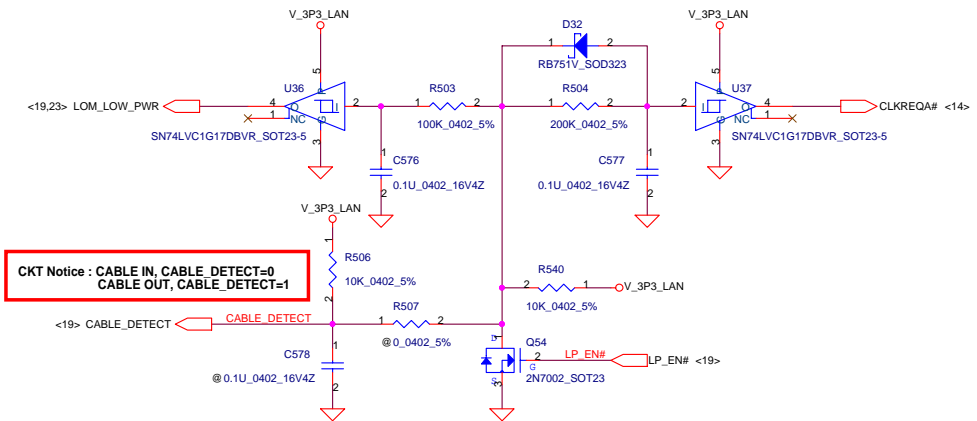

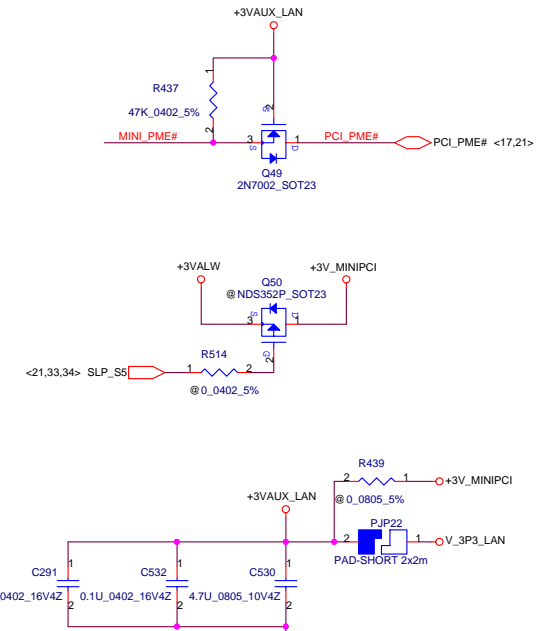
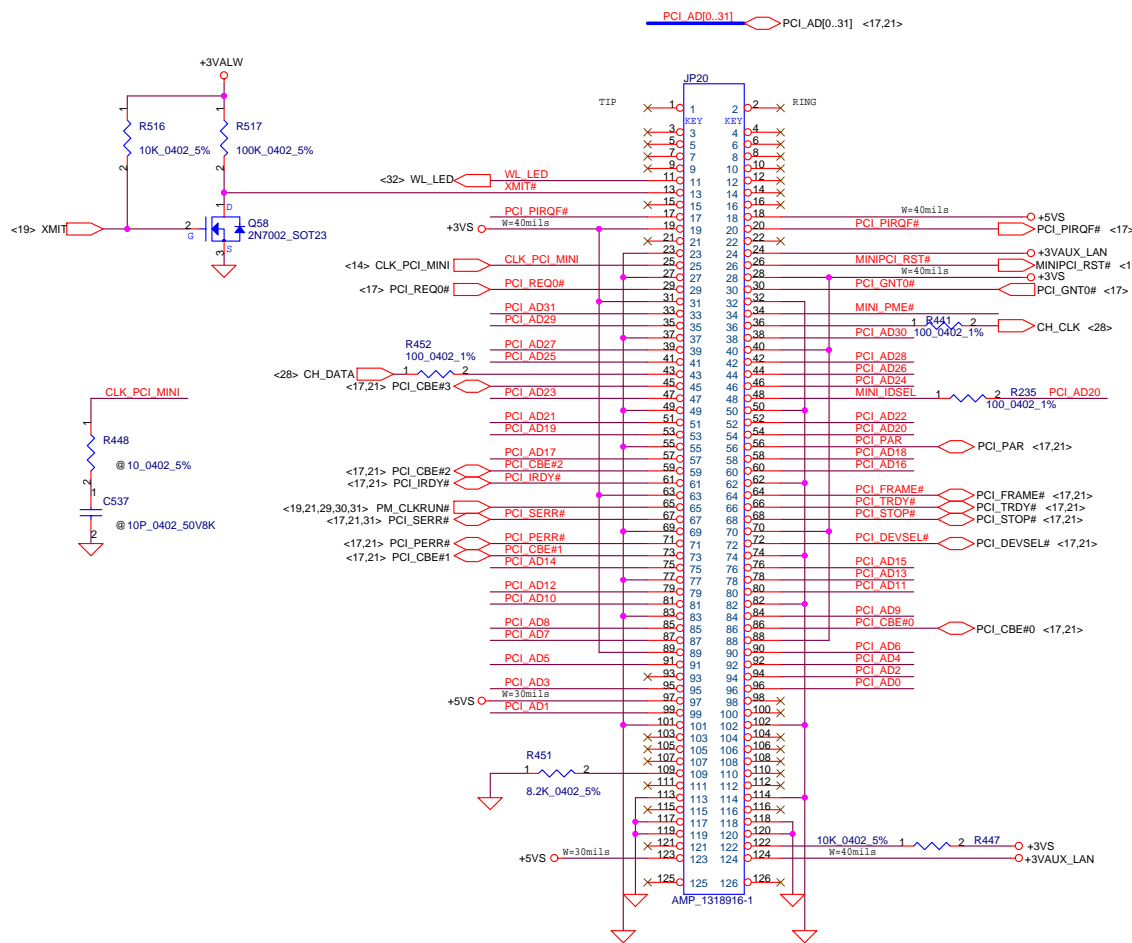
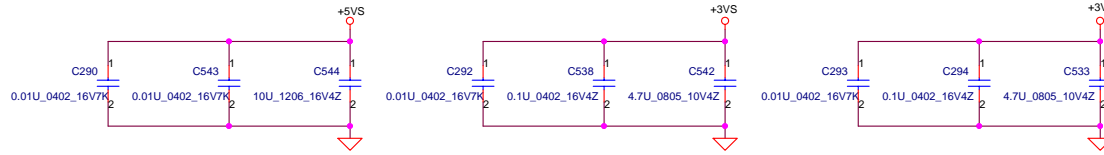

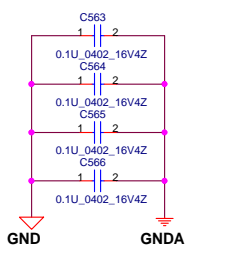
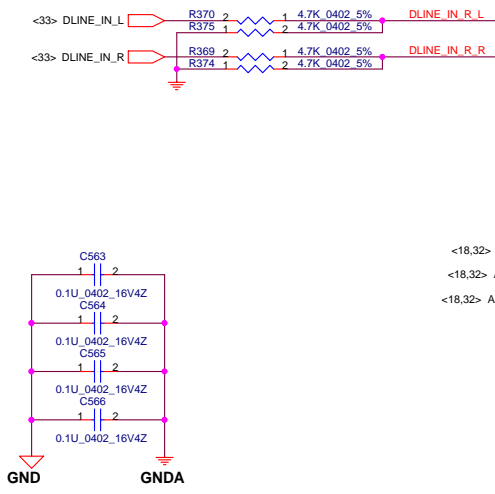
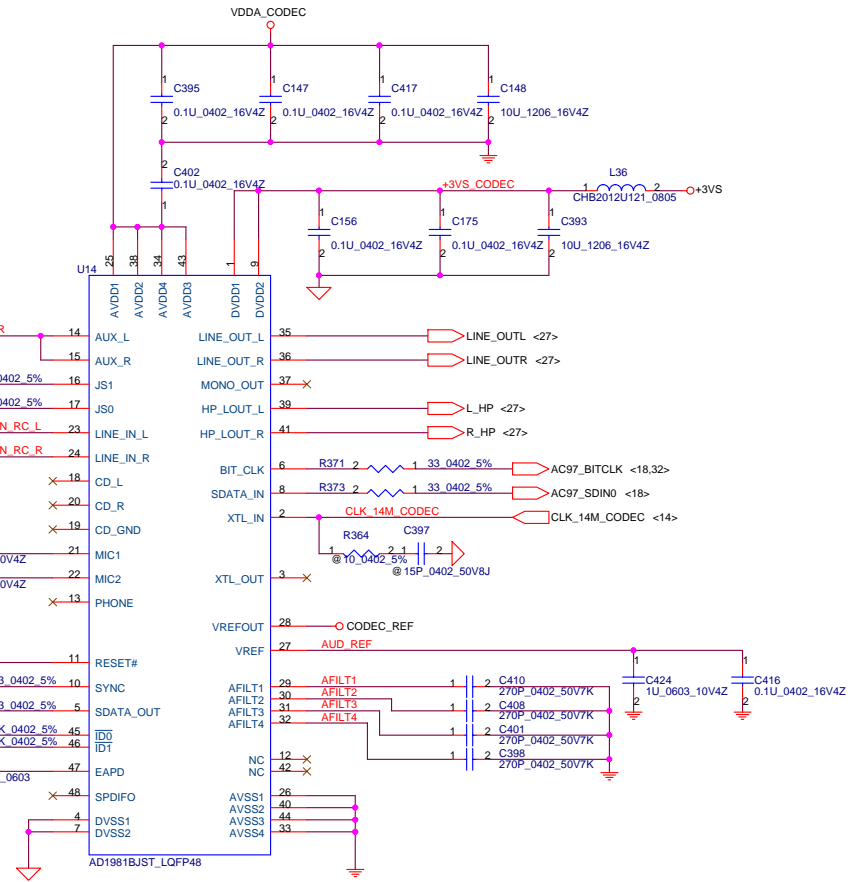
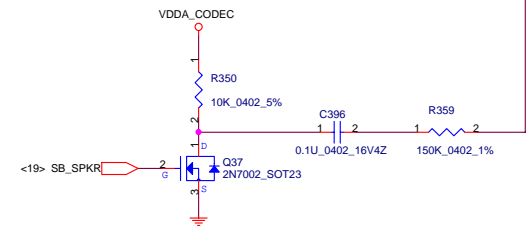
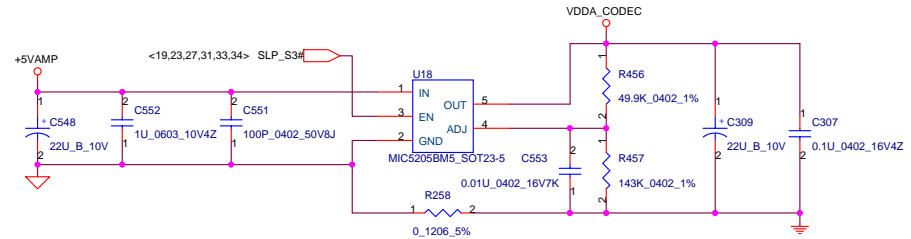
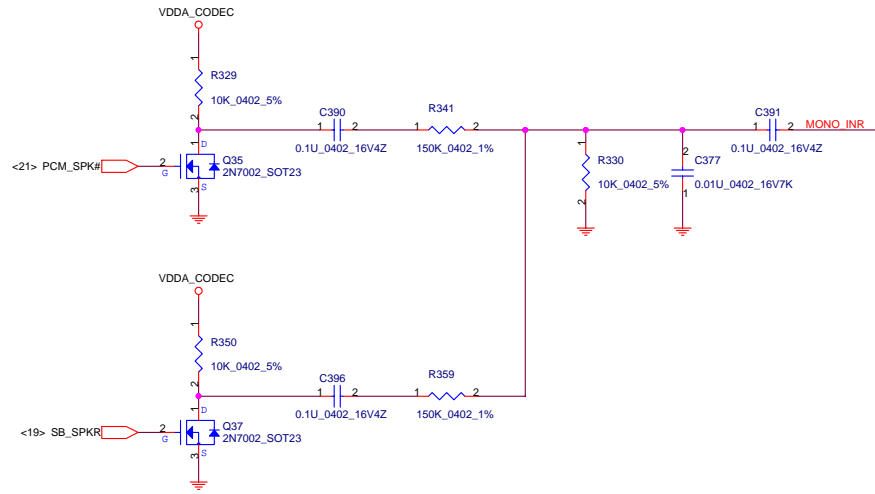

AMP. FOR INTERNAL SPEAKER

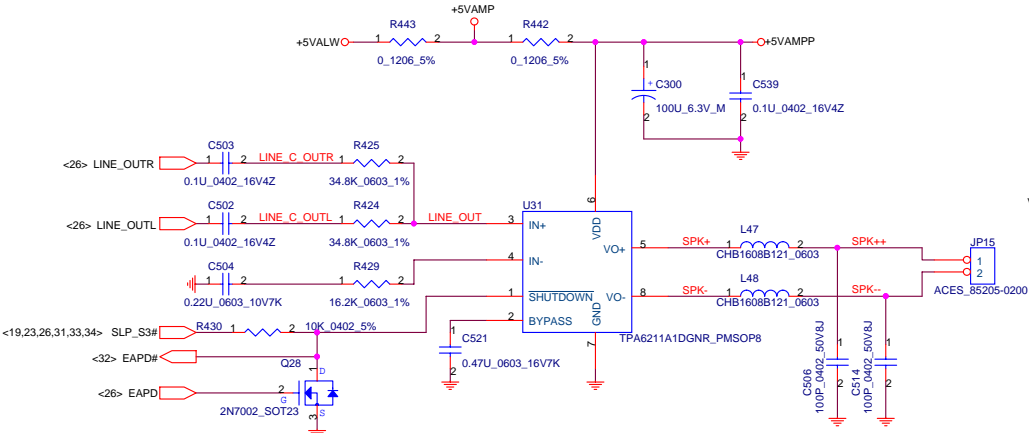

AMP. FOR INTERNAL MICROPHONE

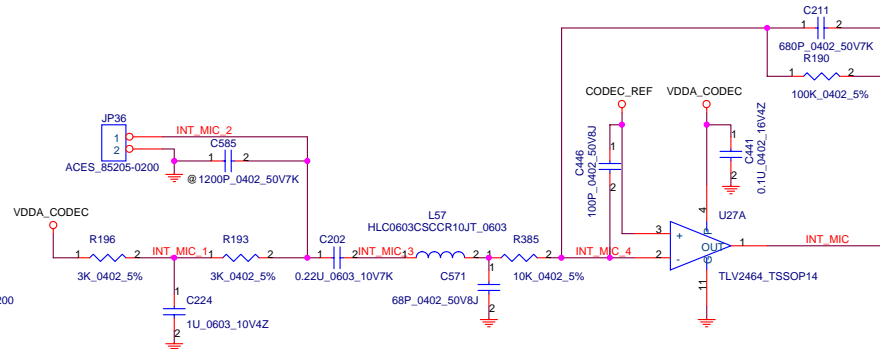

AMP. FOR EXTERNAL MICROPHONE

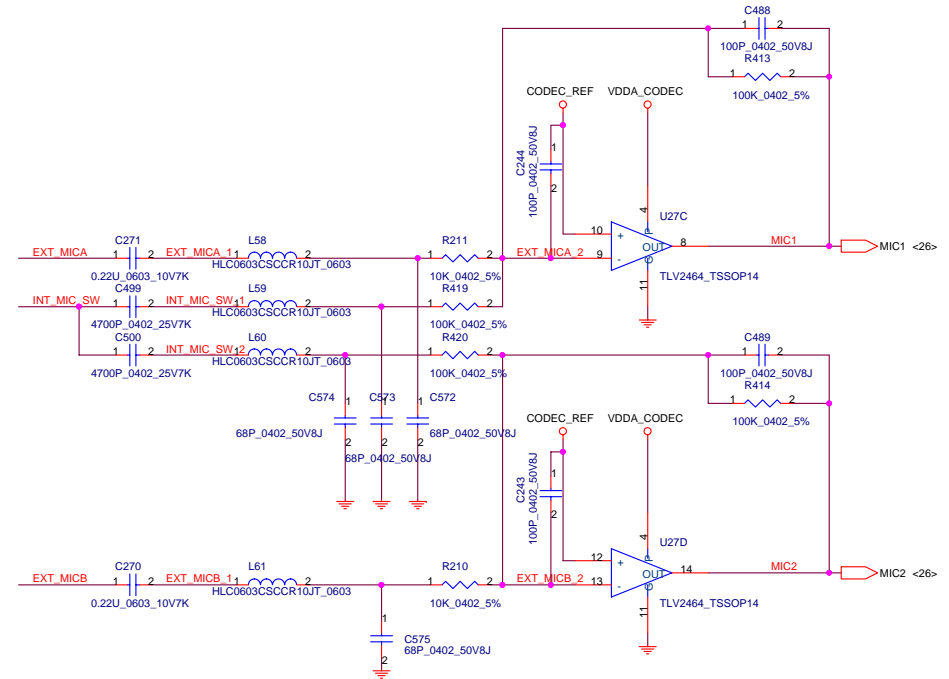

LINE OUT/HEADPHONES AUDIO JACK

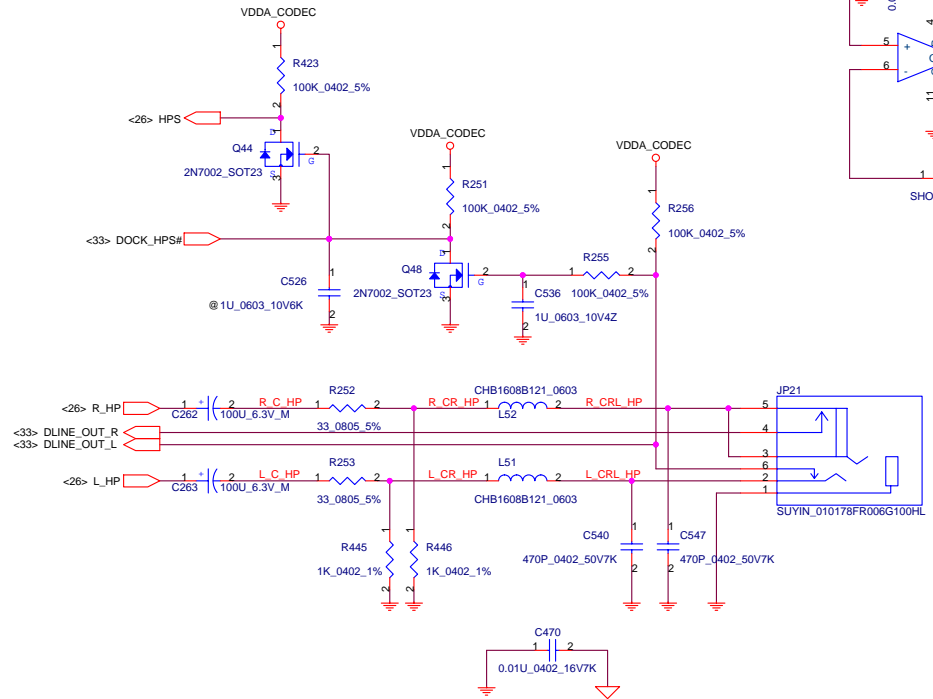

UNUSED

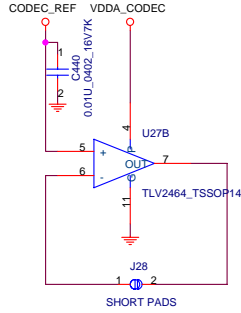

EXT. MICIN AUDIO JACK

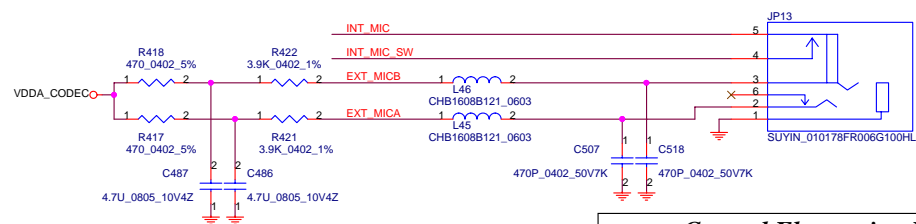

Compal Electronics, Inc.	
AMP & Audio Jack	
Title	Revision
Document Number	Rev 0.6
DATE: 09-09-04	DATE: 09-09-04
Sheet 27	of 48

THIS SHEET OF ENGINEERING DRAWING IS THE PROPRIETARY PROPERTY OF COMPAL ELECTRONICS, INC. AND CONTAINS TRADE SECRET INFORMATION. THIS SHEET MAY NOT BE TRANSFERRED FROM THE CUSTODY OF THE COMPETENT DIVISION OF COMPAL ELECTRONICS, INC. DEPARTMENT EXCEPT AS AUTHORIZED BY COMPAL ELECTRONICS, INC. NEITHER THIS SHEET NOR THE INFORMATION IT CONTAINS MAY BE USED BY OR DISCLOSED TO ANY THIRD PARTY WITHOUT PRIOR WRITTEN CONSENT OF COMPAL ELECTRONICS, INC.

USB CONNECTOR 1

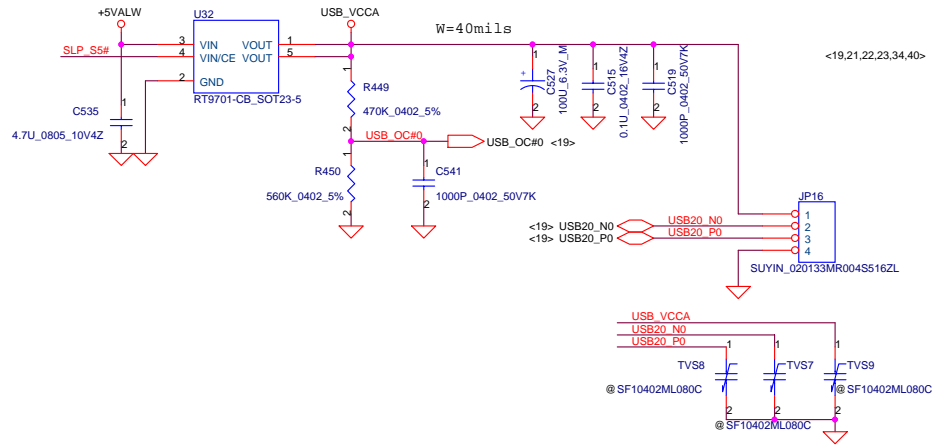

USB CONNECTOR 2

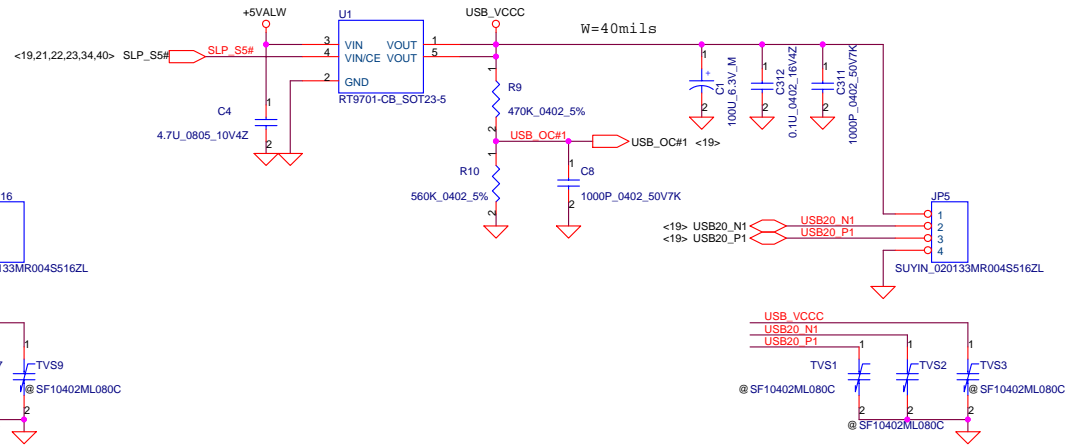

USB CONNECTOR 3

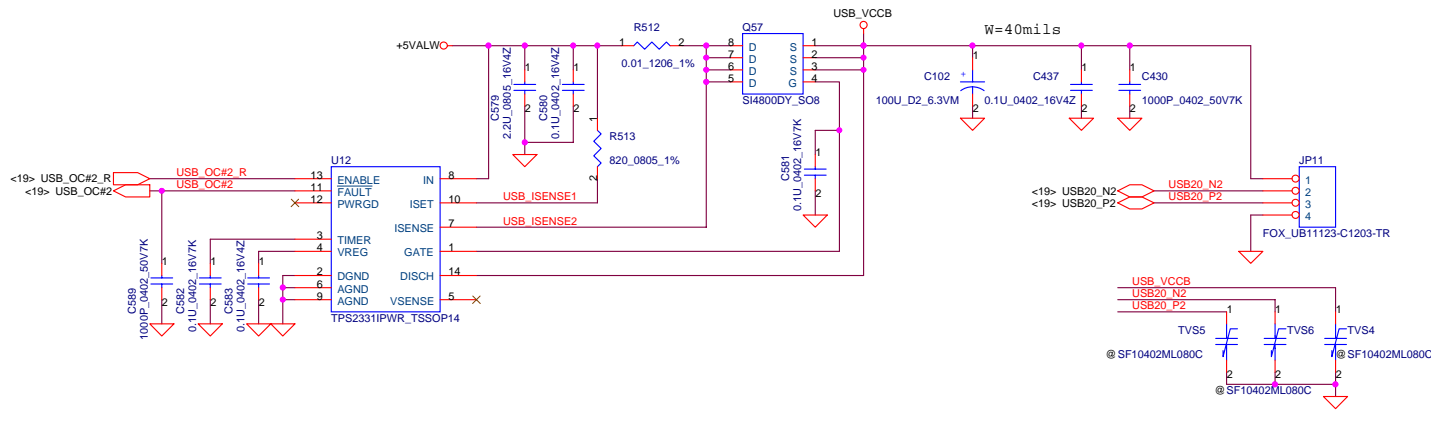

BT Connector

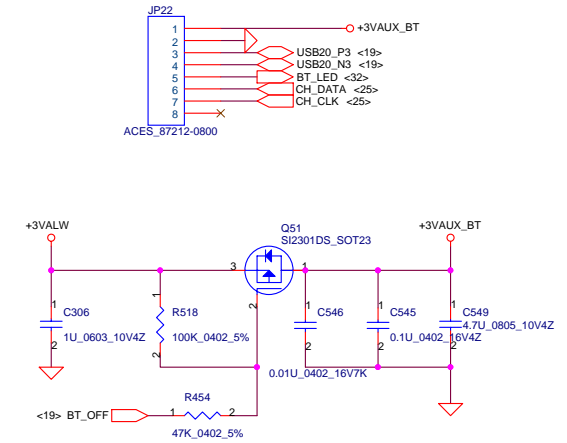

Compal Electronics, Inc.

USB & BT Connector

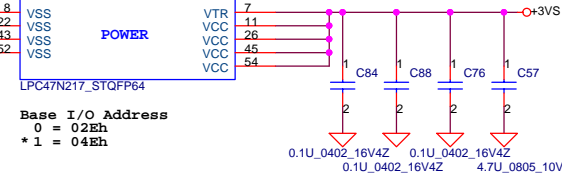
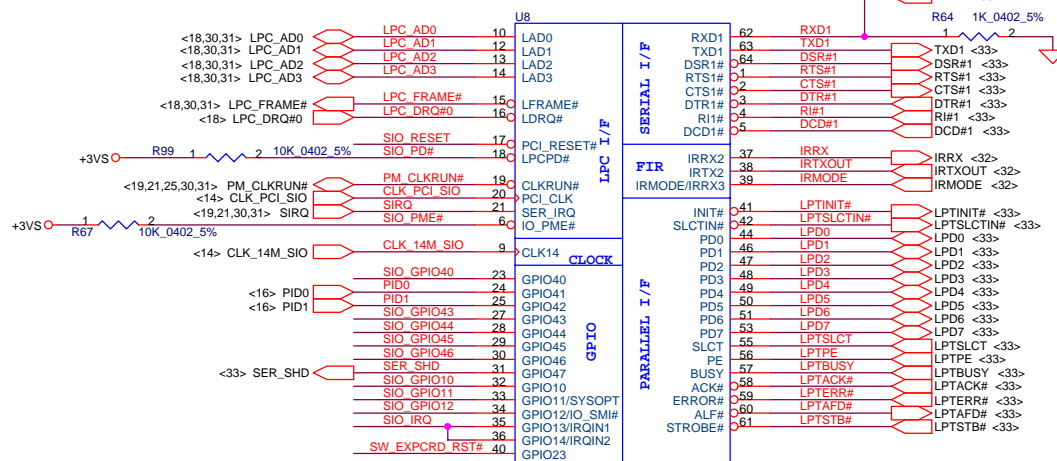
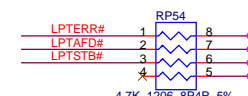
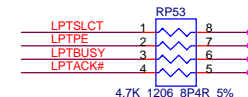
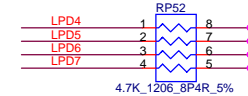
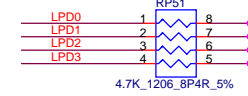
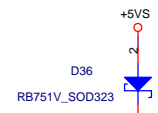
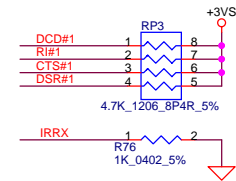
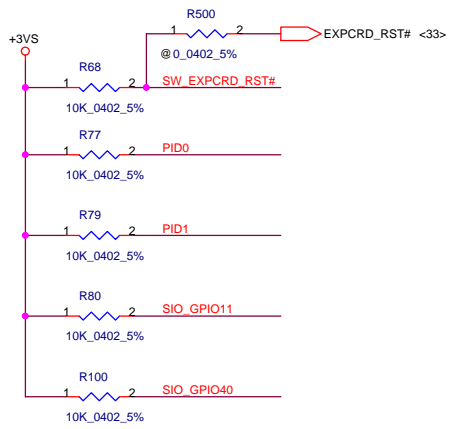
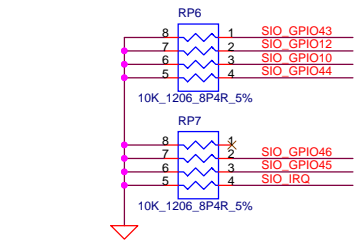
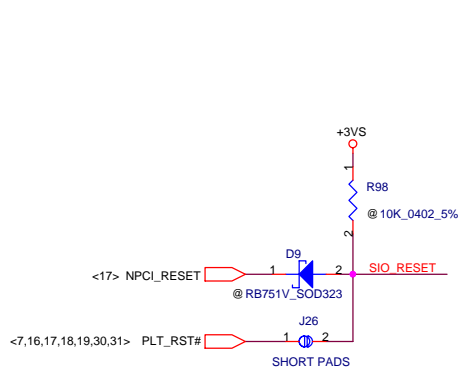

Base I/O Address
 0 = 02Eh
 * 1 = 04Eh

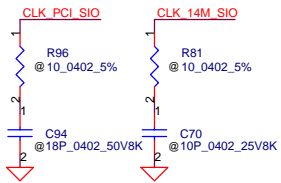

THIS SHEET OF ENGINEERING DRAWING IS THE PROPRIETARY PROPERTY OF COMPAL ELECTRONICS, INC. AND CONTAINS TRADE SECRET INFORMATION. THIS SHEET MAY NOT BE TRANSFERRED FROM THE CUSTODY OF THE COMPETENT DIVISION OF COMPAL ELECTRONICS, INC. DEPARTMENT EXCEPT AS AUTHORIZED BY COMPAL ELECTRONICS, INC. NEITHER THIS SHEET NOR THE INFORMATION IT CONTAINS MAY BE USED BY OR DISCLOSED TO ANY THIRD PARTY WITHOUT PRIOR WRITTEN CONSENT OF COMPAL ELECTRONICS, INC.

BIOS ROM

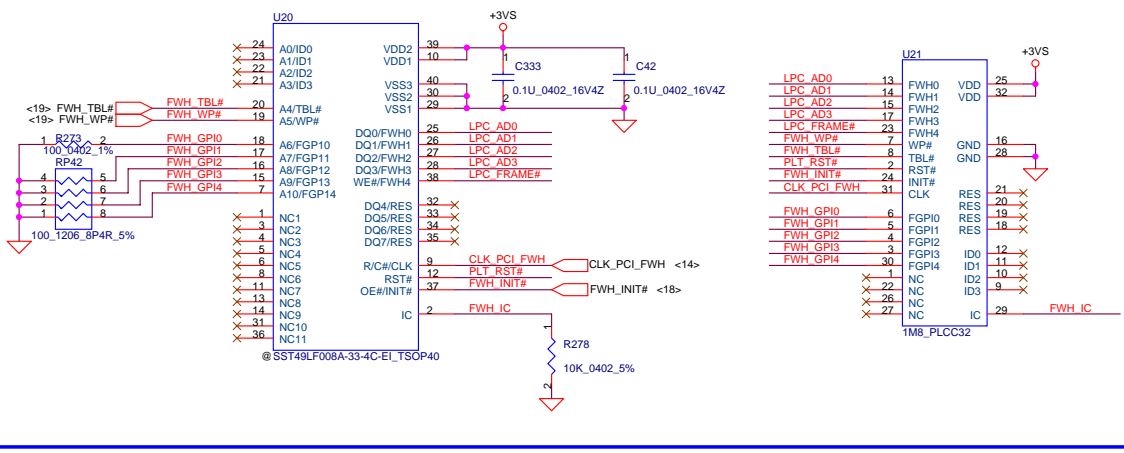

Wireless/BT ON & OFF Button

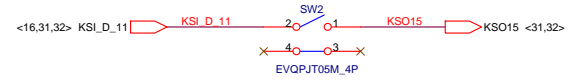

QuickLook Button

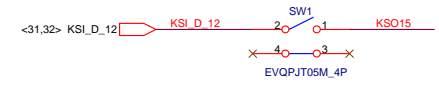

ON/OFF & SLEEP Button

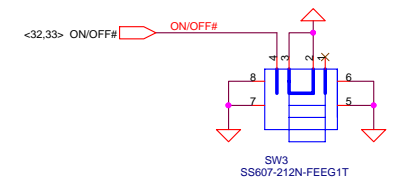

TPM Module

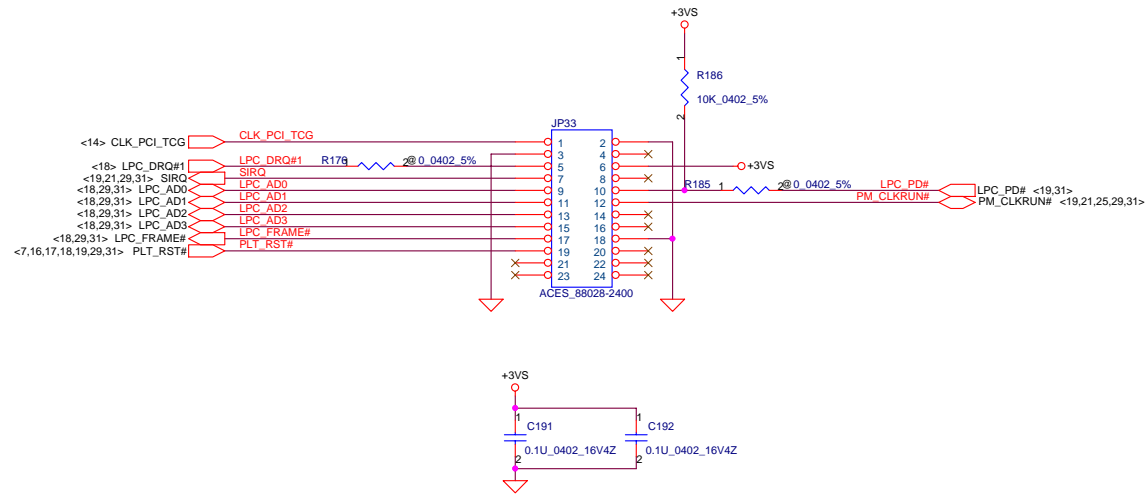

GREEN POWER LED

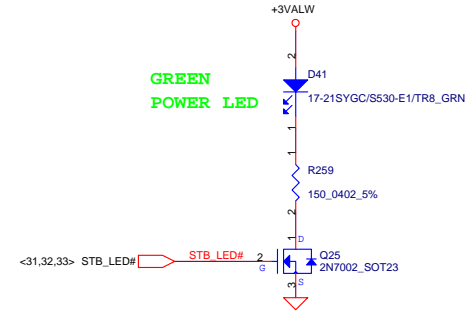

GREEN CAP LED

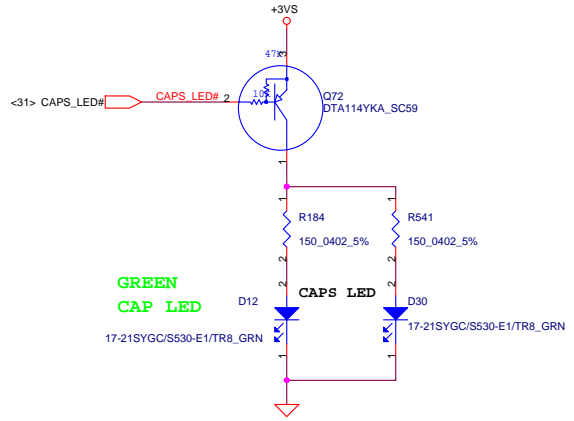

Compal Electronics, Inc.
TCG/BIOS ROM/PS2/LED/SW
 Title: _____
 Revision: _____
 Date: Thursday, September 09, 2004 Sheet 30 of 48

THIS SHEET OF ENGINEERING DRAWING IS THE PROPRIETARY PROPERTY OF COMPAL ELECTRONICS, INC. AND CONTAINS TRADE SECRET INFORMATION. THIS SHEET MAY NOT BE TRANSFERRED FROM THE CUSTODY OF THE COMPETENT DESIGN DEPARTMENT EXCEPT AS AUTHORIZED BY COMPAL ELECTRONICS, INC. NEITHER THIS SHEET NOR THE INFORMATION IT CONTAINS MAY BE USED BY OR DISCLOSED TO ANY THIRD PARTY WITHOUT PRIOR WRITTEN CONSENT OF COMPAL ELECTRONICS, INC.

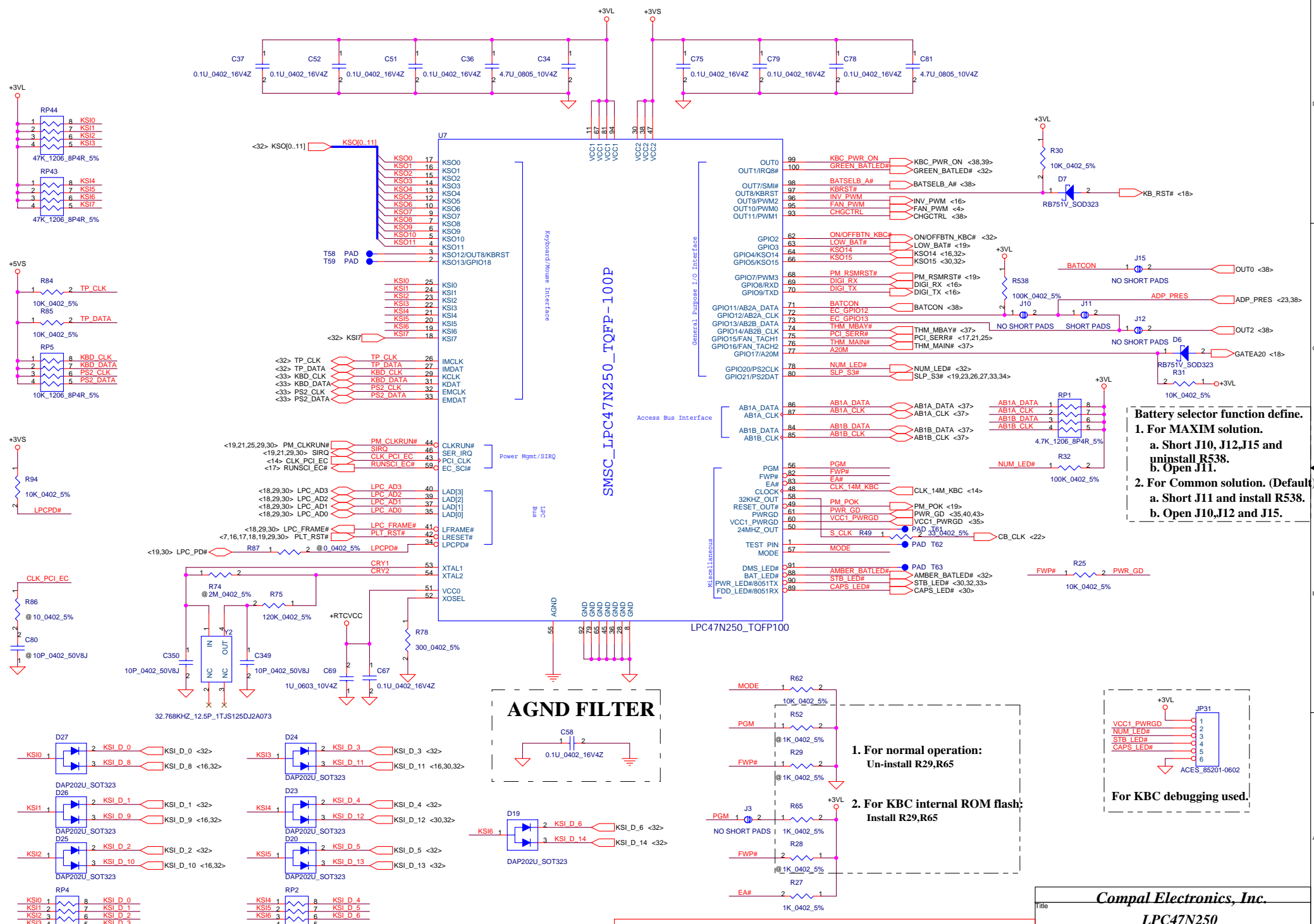

Battery reset function define.

1. For MAXIM solution.
 - a. Short J10, J12, J15 and uninstll R538.
 - b. Open J11.
2. For Common solution. (Default)
 - a. Short J11 and install R538.
 - b. Open J10, J12 and J15.

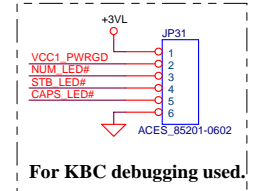
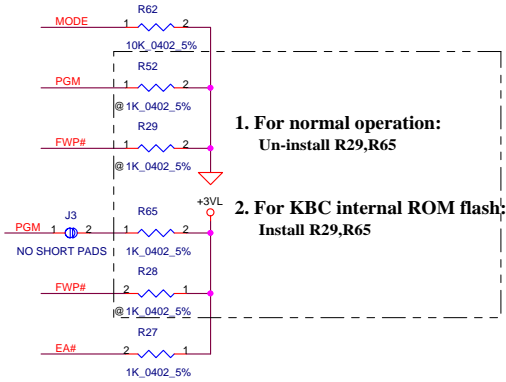
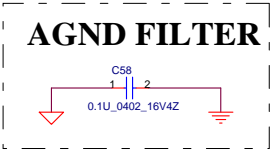

FUN BD.

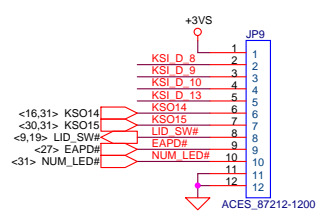

FIR & LED BD.

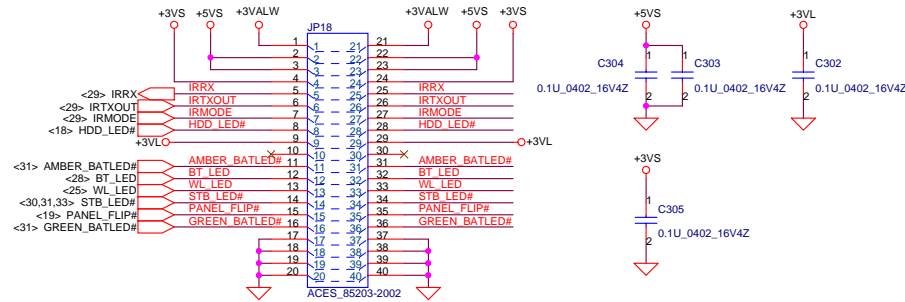

INT_KBD CONN.

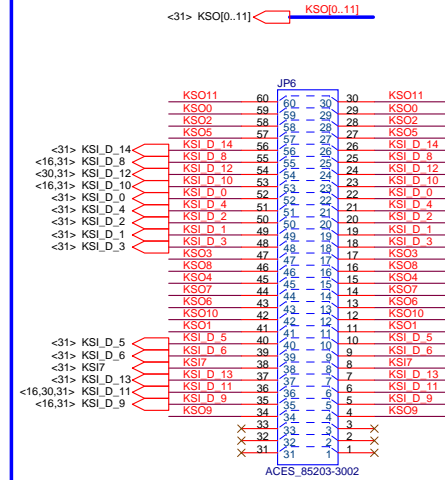

MDC Conn.

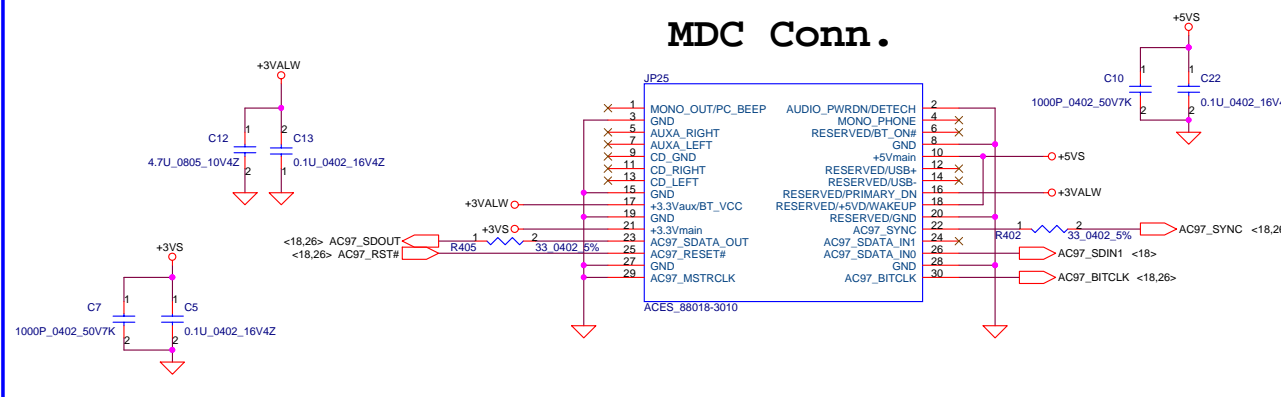

Power button

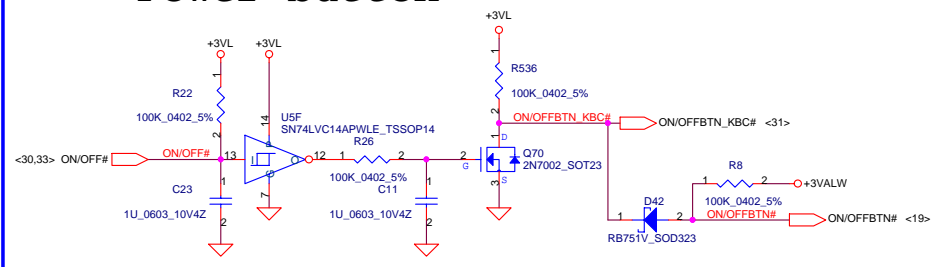

TrackPoint CONN. TP BD.

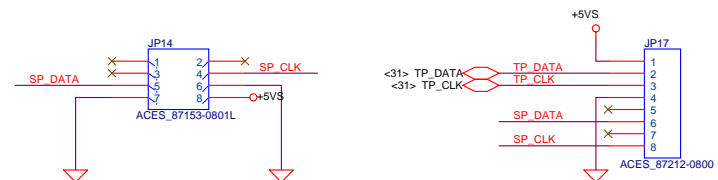

Compal Electronics, Inc.

MDC/KBD/ON_OFF/LID

DOCK CONN. 184PIN

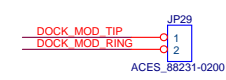
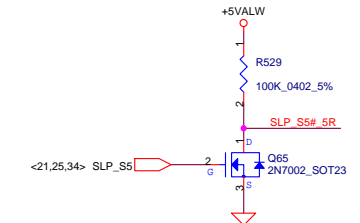
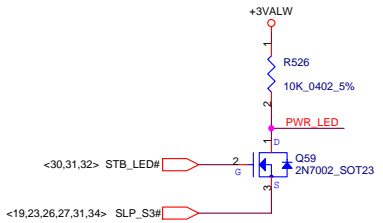
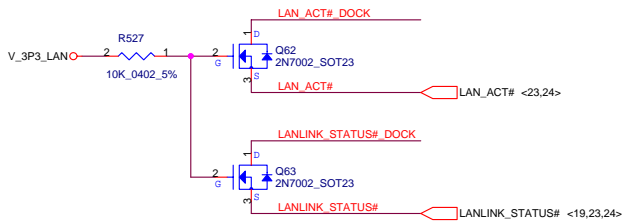
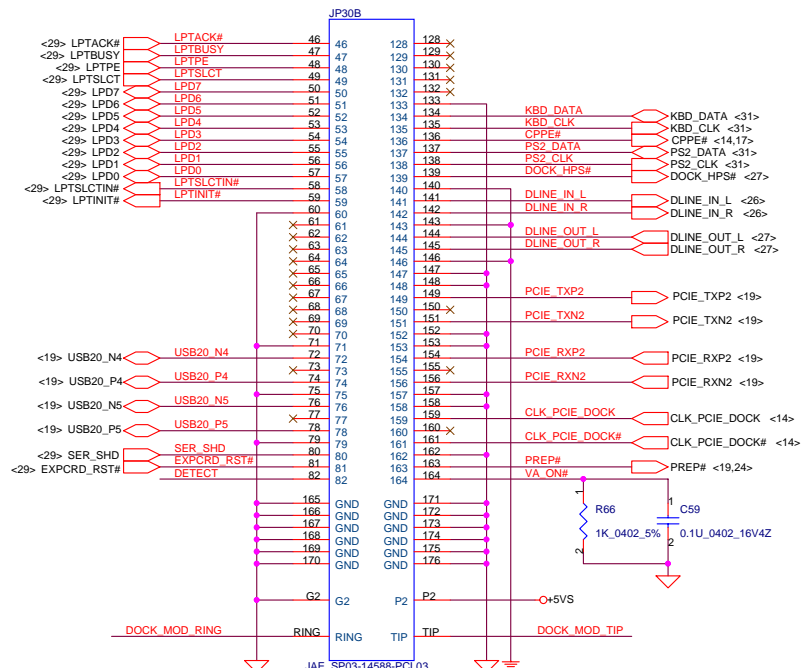
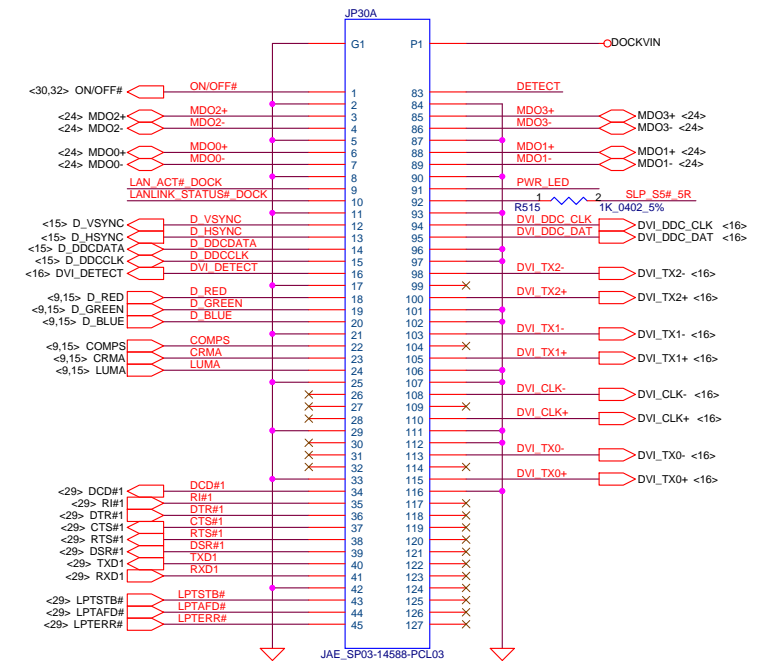
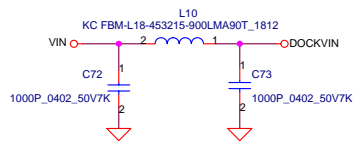

+1.5VALW to +1.5VS Transfer

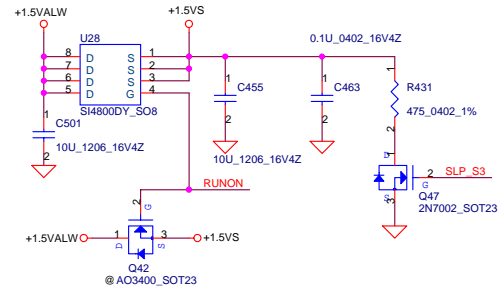

+1.8V to +1.8VS Transfer

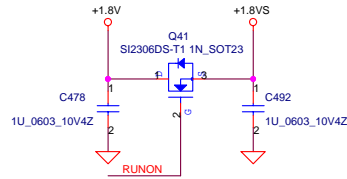

+3VALW to +3VS Transfer

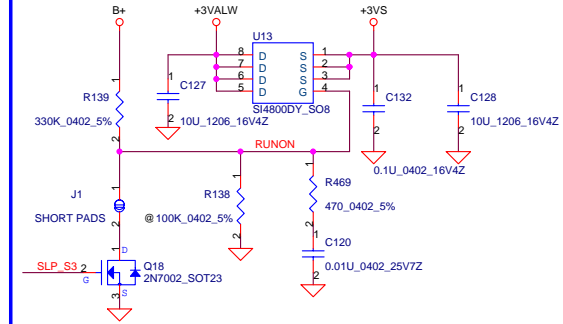

+2.5VALW to V_2P5_LAN Transfer

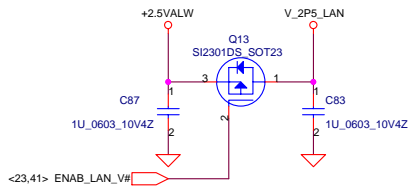

+2.5VALW to +2.5VS Transfer

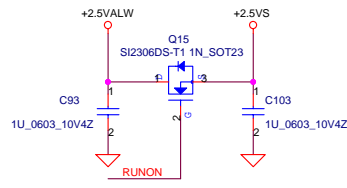

+5VALW to +5VS Transfer

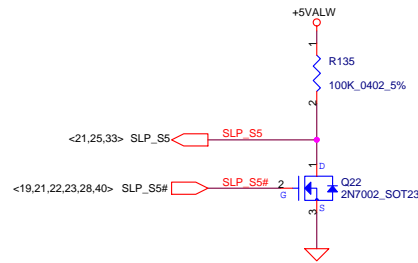
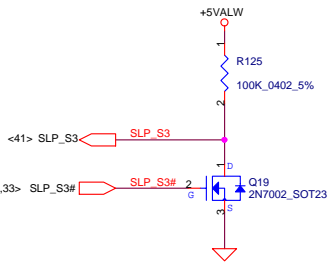
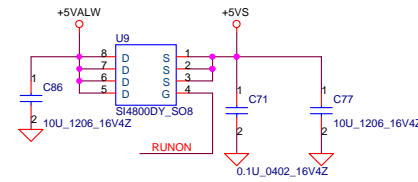

Discharge circuit

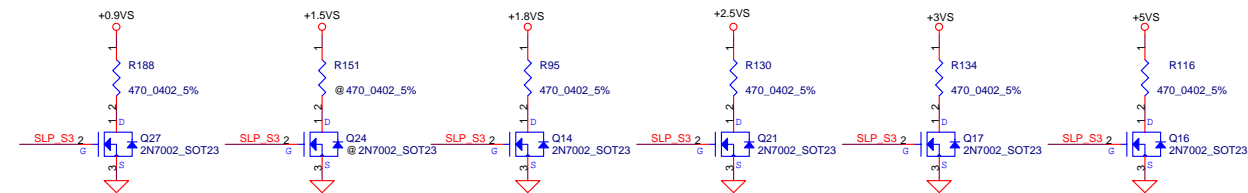

Compal Electronics, Inc.

Title	DC/DC Circuits
Revision	0.6
Date	Thursday, September 09, 2004
Sheet	34 of 48

THIS SHEET OF ENGINEERING DRAWING IS THE PROPRIETARY PROPERTY OF COMPAL ELECTRONICS, INC. AND CONTAINS TRADE SECRET INFORMATION. THIS SHEET MAY NOT BE TRANSFERRED FROM THE CUSTODY OF THE COMPETENT DIVISION OF COMPAL ELECTRONICS, INC. WITHOUT THE WRITTEN CONSENT OF COMPAL ELECTRONICS, INC. NEITHER THIS SHEET NOR THE INFORMATION IT CONTAINS MAY BE USED BY OR DISCLOSED TO ANY THIRD PARTY WITHOUT PRIOR WRITTEN CONSENT OF COMPAL ELECTRONICS, INC.

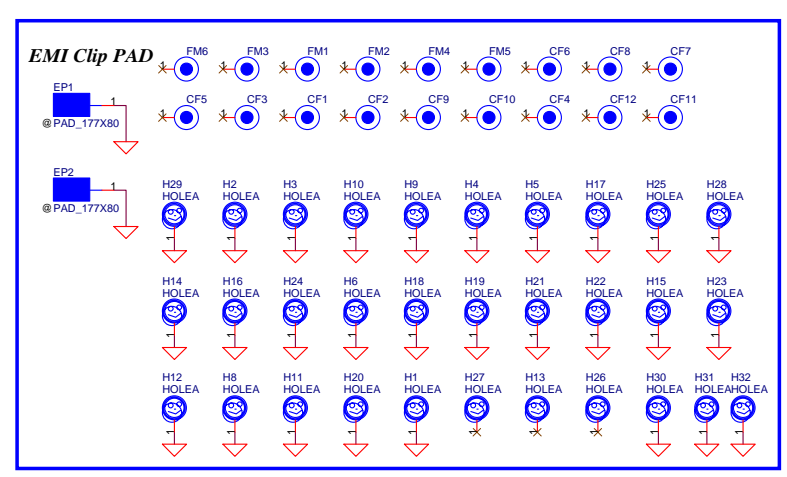
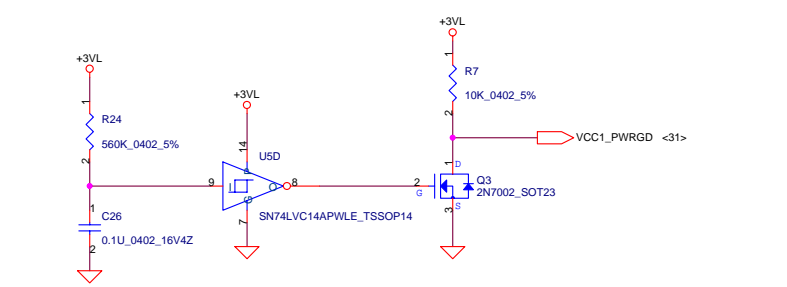
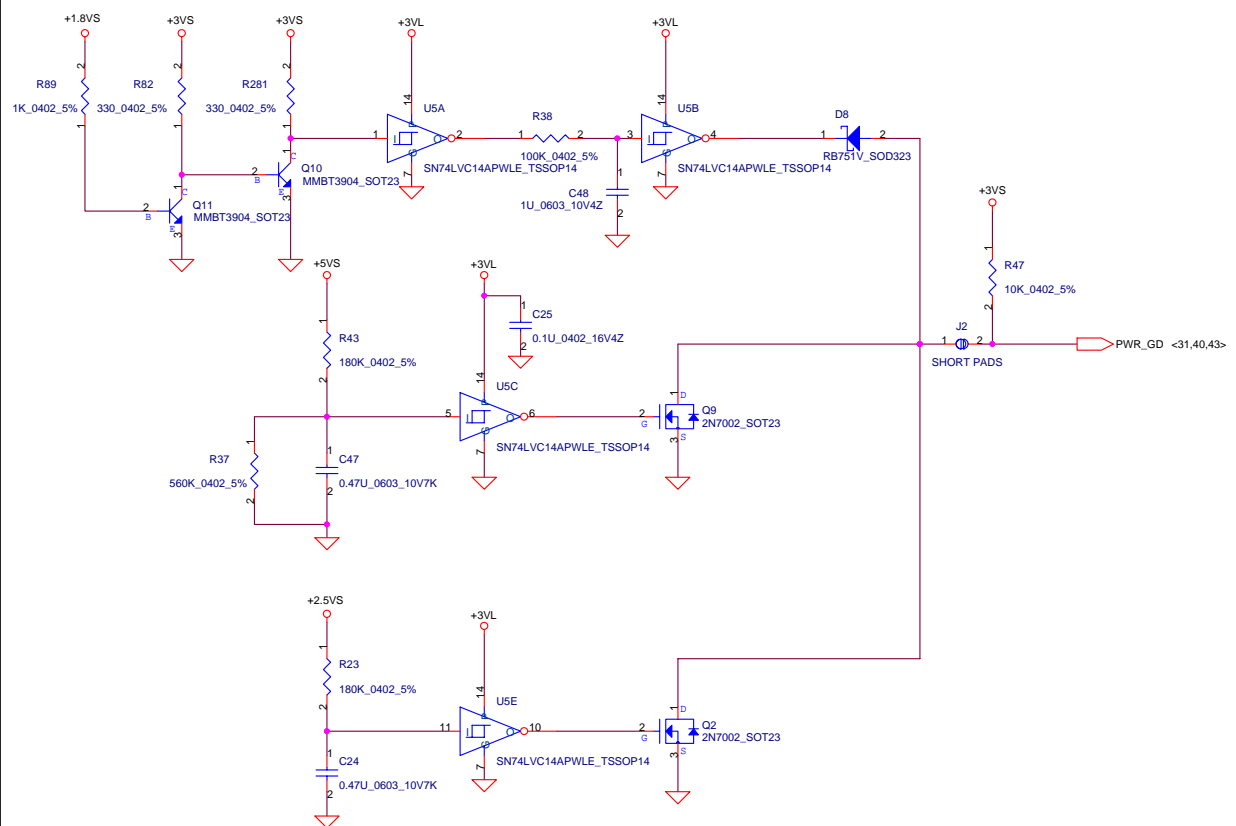

Compal Electronics, Inc.	
Title	POK CKT
Revision	0.6
Date	Thursday, September 09, 2004
Sheet	35 of 48

THIS SHEET OF ENGINEERING DRAWING IS THE PROPRIETARY PROPERTY OF COMPAL ELECTRONICS, INC. AND CONTAINS TRADE SECRET INFORMATION. THIS SHEET MAY NOT BE TRANSFERRED FROM THE CUSTODY OF THE COMPETENT DIVISION OF COMPAL ELECTRONICS, INC. NEITHER THIS SHEET NOR THE INFORMATION IT CONTAINS MAY BE USED BY OR DISCLOSED TO ANY THIRD PARTY WITHOUT PRIOR WRITTEN CONSENT OF COMPAL ELECTRONICS, INC.

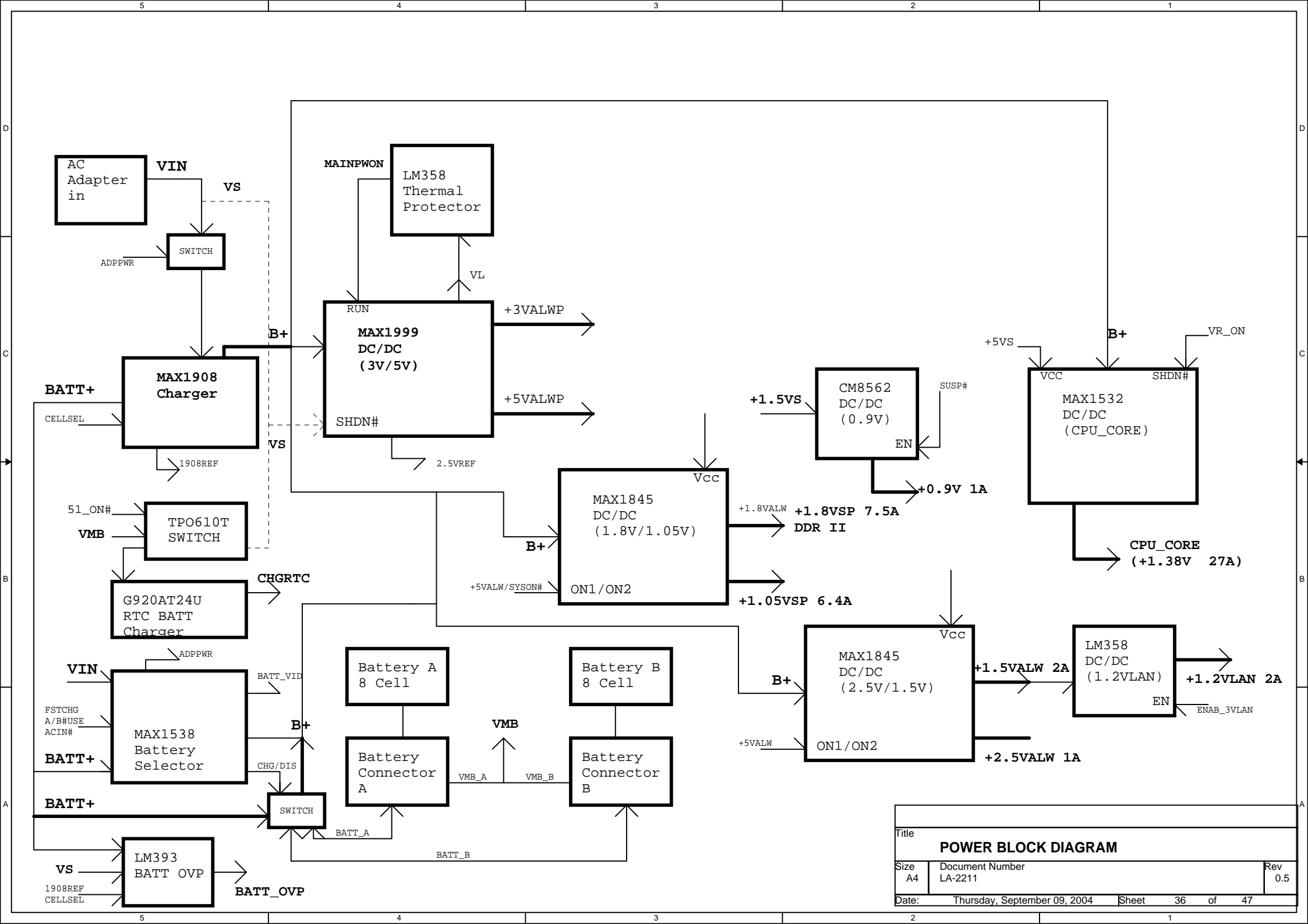

Title		
POWER BLOCK DIAGRAM		
Size	Document Number	Rev
A4	LA-2211	0.5
Date:	Thursday, September 09, 2004	Sheet 36 of 47

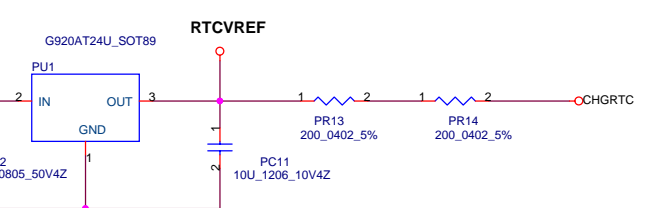
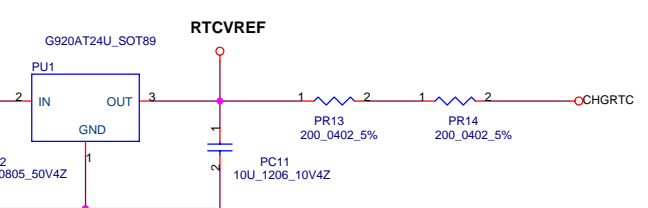
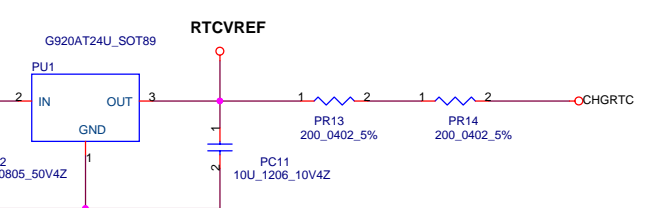
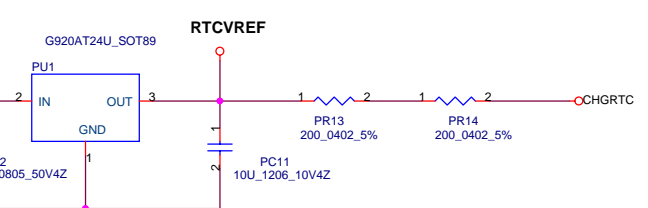
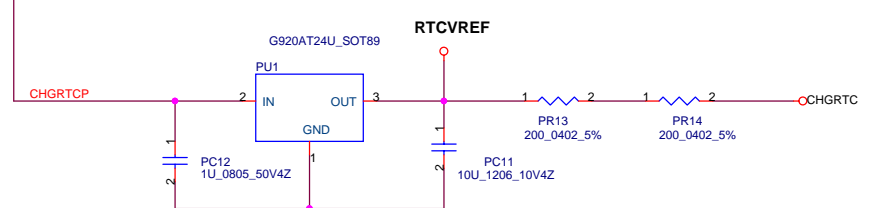
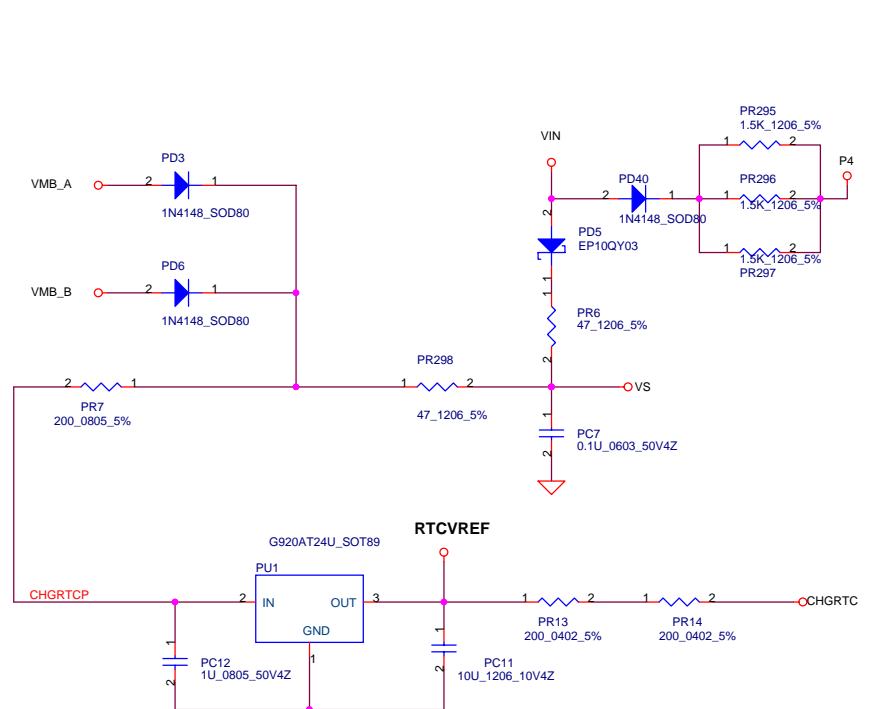
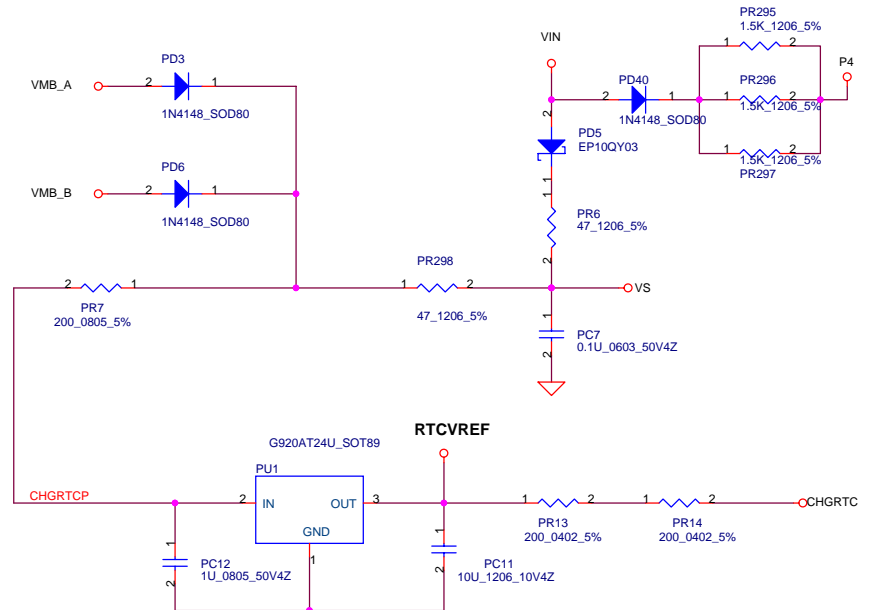
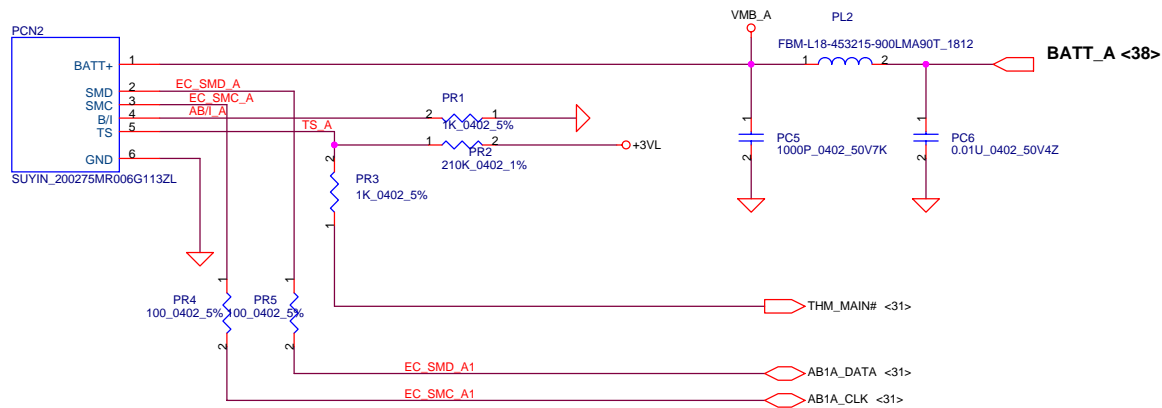
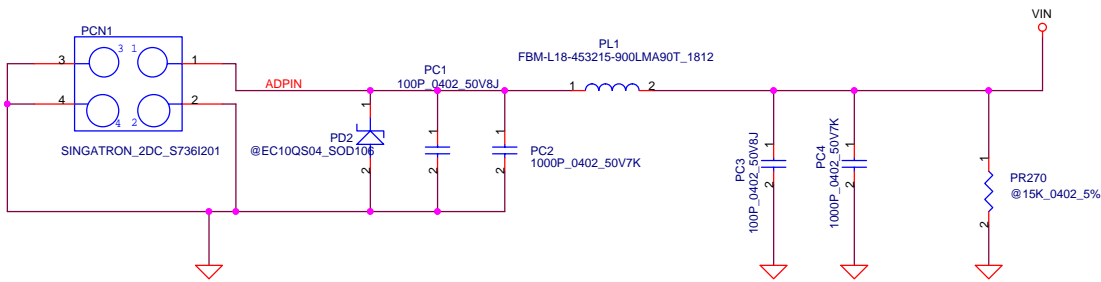

Compal Electronics, Inc.			
Title	BATTERY CONN		
Sheet	37	of	47
Date:	Thursday, September 09, 2004		

THIS SHEET OF ENGINEERING DRAWING IS THE PROPRIETARY PROPERTY OF COMPAL ELECTRONICS, INC. AND CONTAINS TRADE SECRET INFORMATION. THIS SHEET MAY NOT BE TRANSFERRED FROM THE CUSTODY OF THE COMPETENT DIVISION OF R&D DEPARTMENT EXCEPT AS AUTHORIZED BY COMPAL ELECTRONICS, INC. NEITHER THIS SHEET NOR THE INFORMATION IT CONTAINS MAY BE USED BY OR DISCLOSED TO ANY THIRD PARTY WITHOUT PRIOR WRITTEN CONSENT OF COMPAL ELECTRONICS, INC.

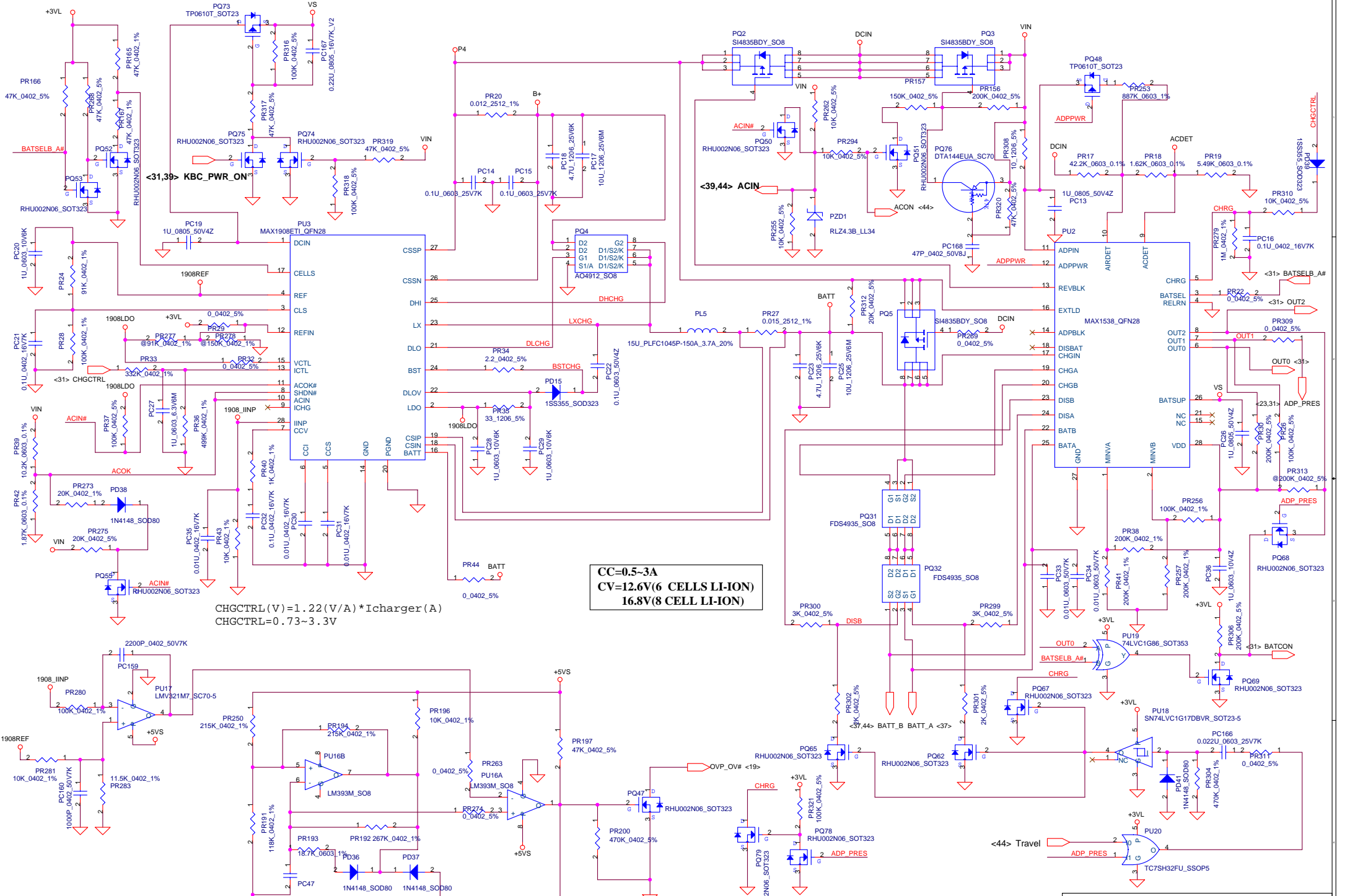

THIS SHEET OF ENGINEERING DRAWING IS THE PROPRIETARY PROPERTY OF COMPAL ELECTRONICS, INC. AND CONTAINS CONFIDENTIAL AND TRADE SECRET INFORMATION. THIS SHEET MAY NOT BE TRANSFERRED FROM THE CUSTODY OF THE COMPETENT DIVISION OF R&D DEPARTMENT EXCEPT AS AUTHORIZED BY COMPAL ELECTRONICS, INC. NEITHER THIS SHEET NOR THE INFORMATION IT CONTAINS MAY BE USED BY OR DISCLOSED TO ANY THIRD PARTY WITHOUT PRIOR WRITTEN CONSENT OF COMPAL ELECTRONICS, INC.

Compal Electronics, Inc.			
Charger			
File	Document Number	Rev	0.5
Size	Custom	Date	Thursday, September 09, 2004
Sheet	38	of	47

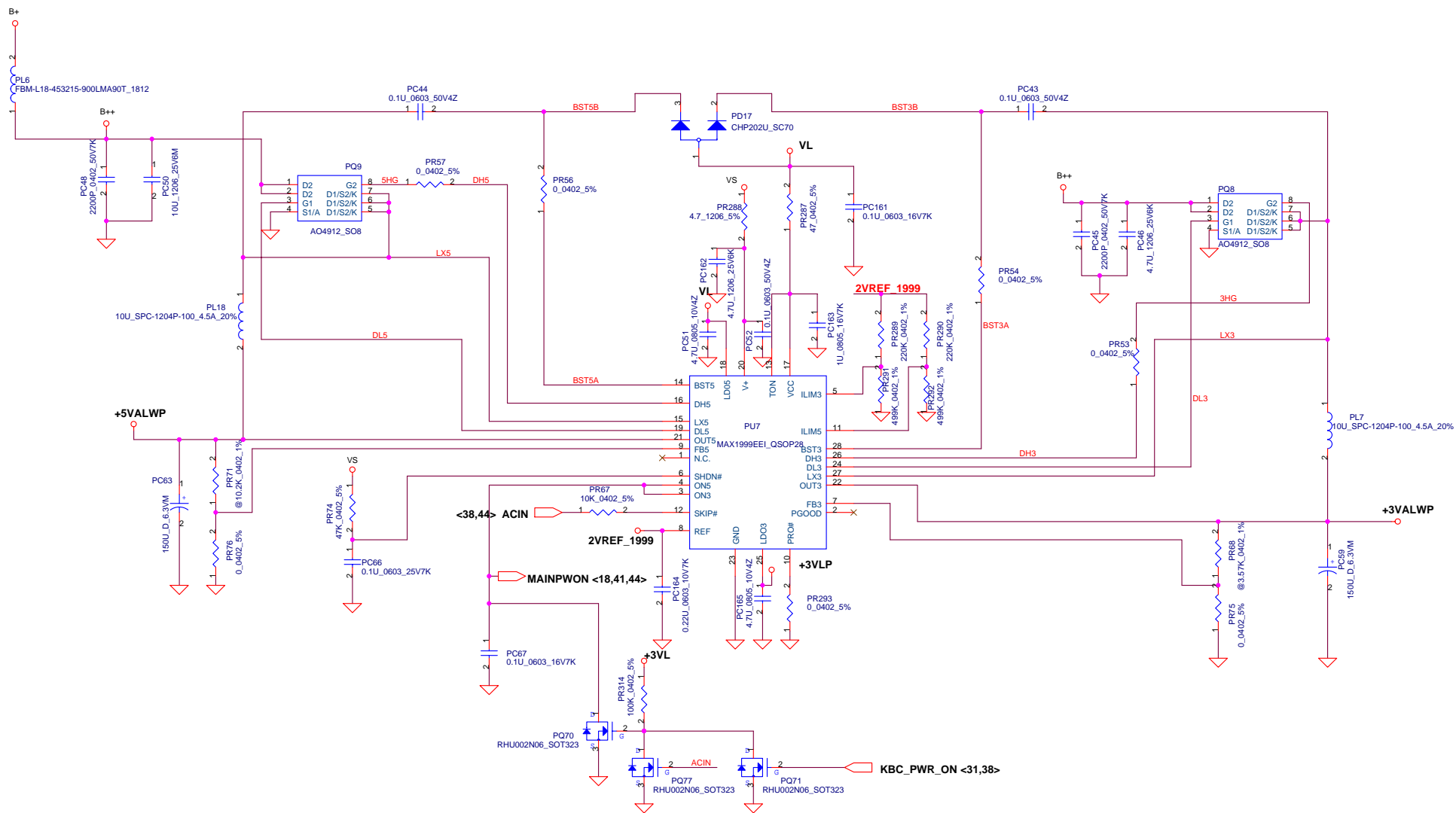

Compal Electronics, Inc.	
Title	3.3V / 5V
Revision	0.1
Date	Thursday, September 09, 2004
Sheet	39 of 47

THIS SHEET OF ENGINEERING DRAWING IS THE PROPRIETARY PROPERTY OF COMPAL ELECTRONICS, INC. AND CONTAINS TRADE SECRET INFORMATION. THIS SHEET MAY NOT BE TRANSFERRED FROM THE CUSTODY OF THE COMPETENT DIVISION OR DEPARTMENT EXCEPT AS AUTHORIZED BY COMPAL ELECTRONICS, INC. NEITHER THIS SHEET NOR THE INFORMATION IT CONTAINS MAY BE USED BY OR DISCLOSED TO ANY THIRD PARTY WITHOUT PRIOR WRITTEN CONSENT OF COMPAL ELECTRONICS, INC.

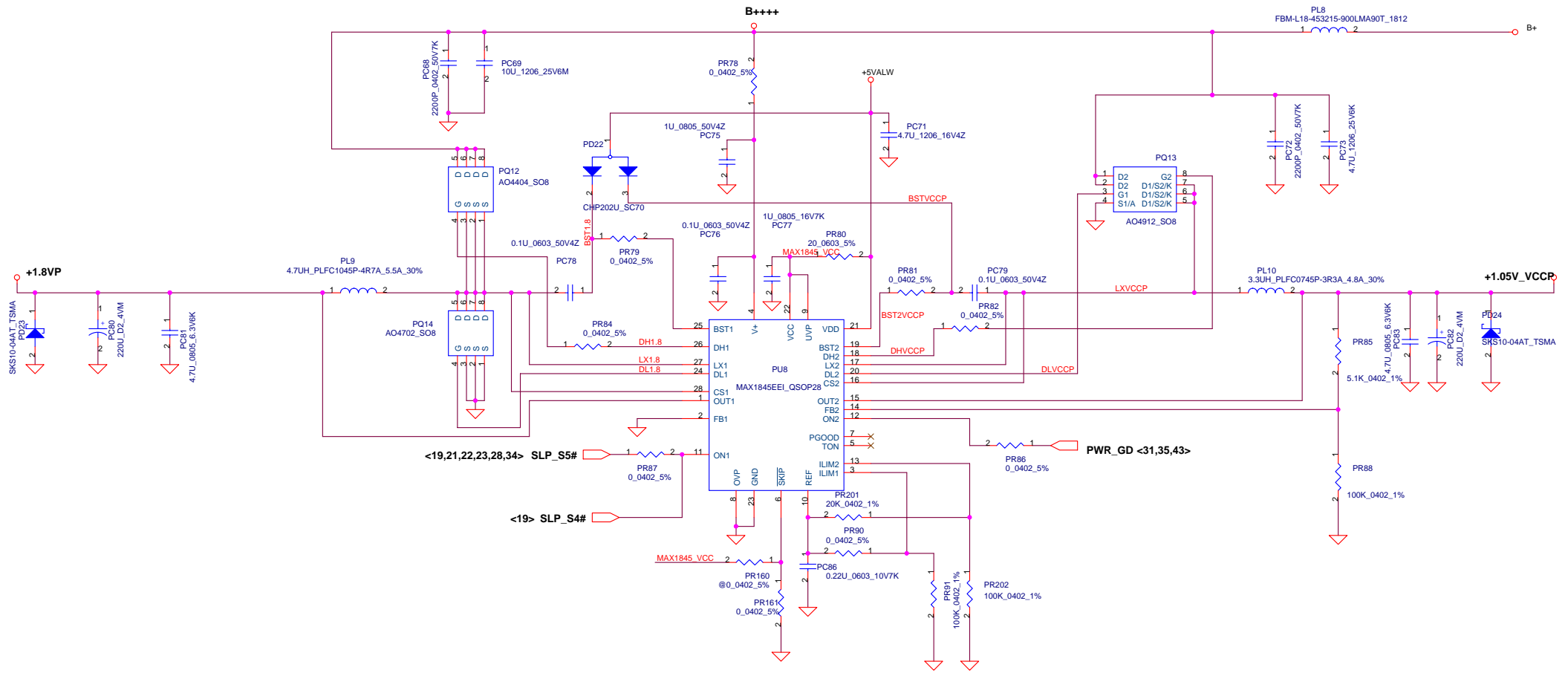

THIS SHEET OF ENGINEERING DRAWING IS THE PROPRIETARY PROPERTY OF COMPAL ELECTRONICS, INC. AND CONTAINS TRADE SECRET INFORMATION. THIS SHEET MAY NOT BE TRANSFERRED FROM THE CUSTODY OF THE COMPETENT DIVISION OF R&D DEPARTMENT EXCEPT AS AUTHORIZED BY COMPAL ELECTRONICS, INC. NEITHER THIS SHEET NOR THE INFORMATION IT CONTAINS MAY BE USED BY OR DISCLOSED TO ANY THIRD PARTY WITHOUT PRIOR WRITTEN CONSENT OF COMPAL ELECTRONICS, INC.

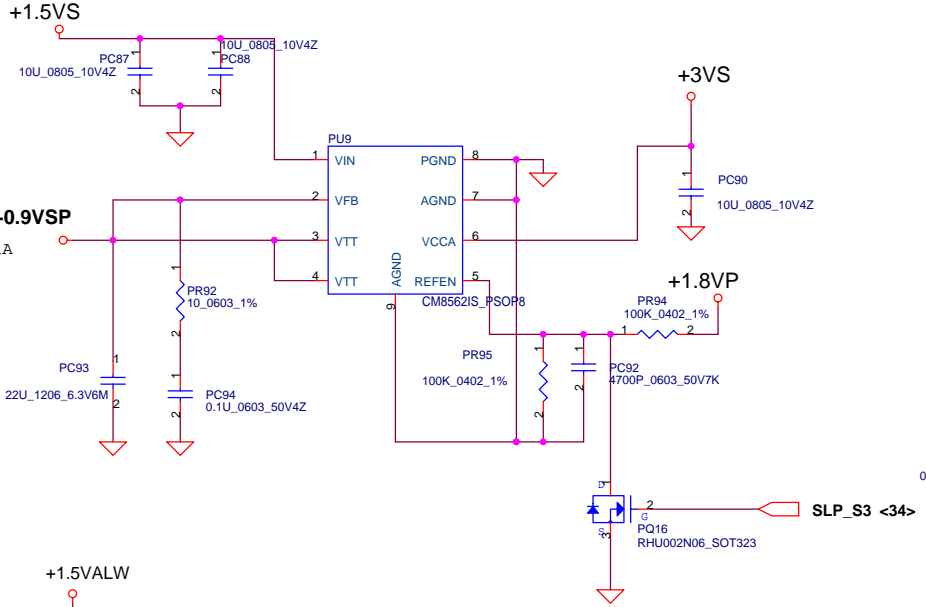

PH1 under BATT botten side :
 CPU thermal protection at 90 +/- 3 degree C
 Recovery at 43 +/- 3 degree C

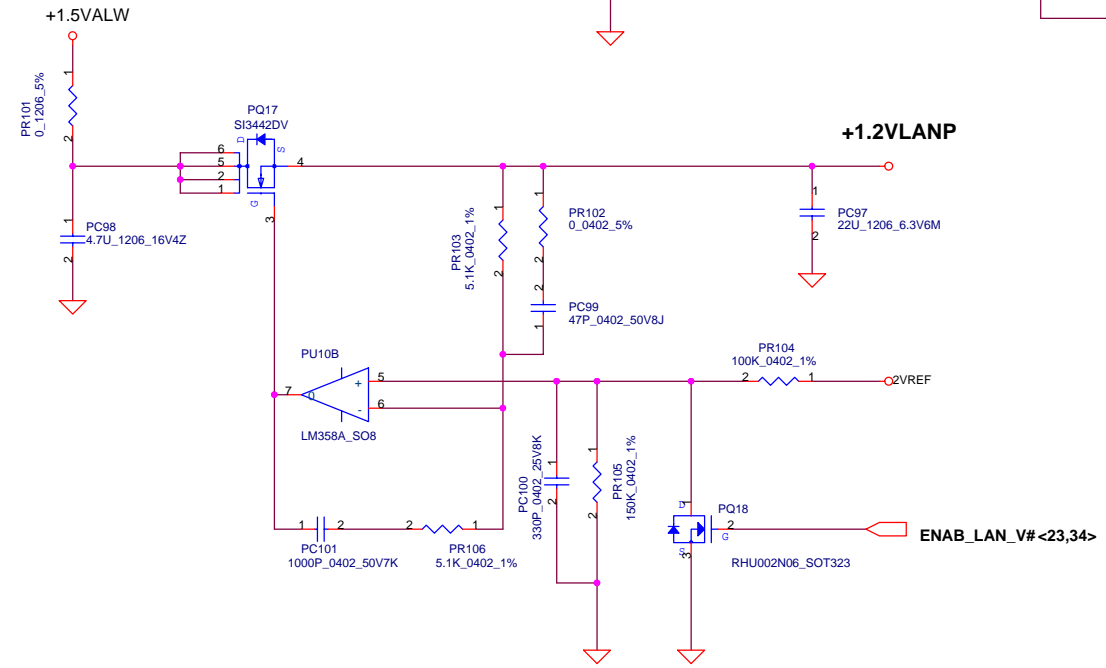
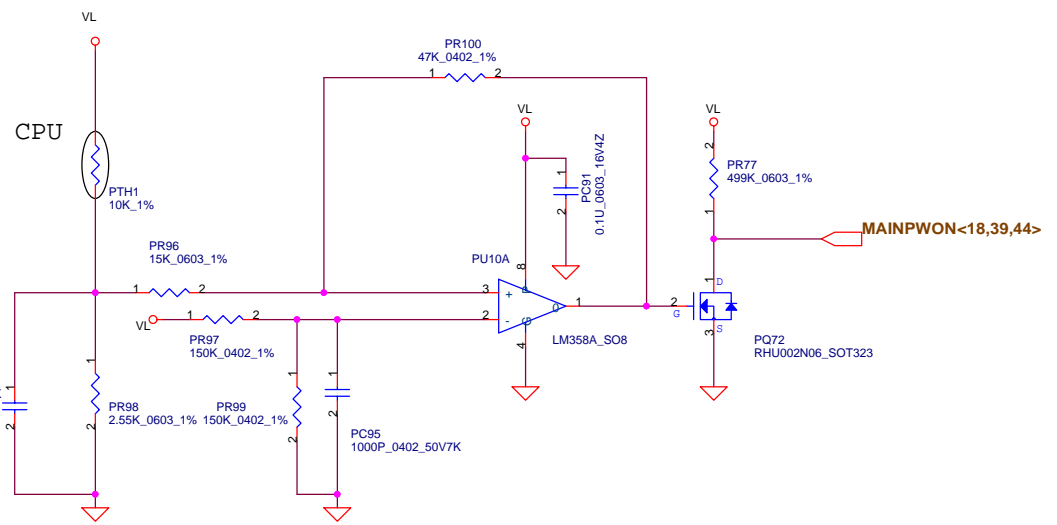

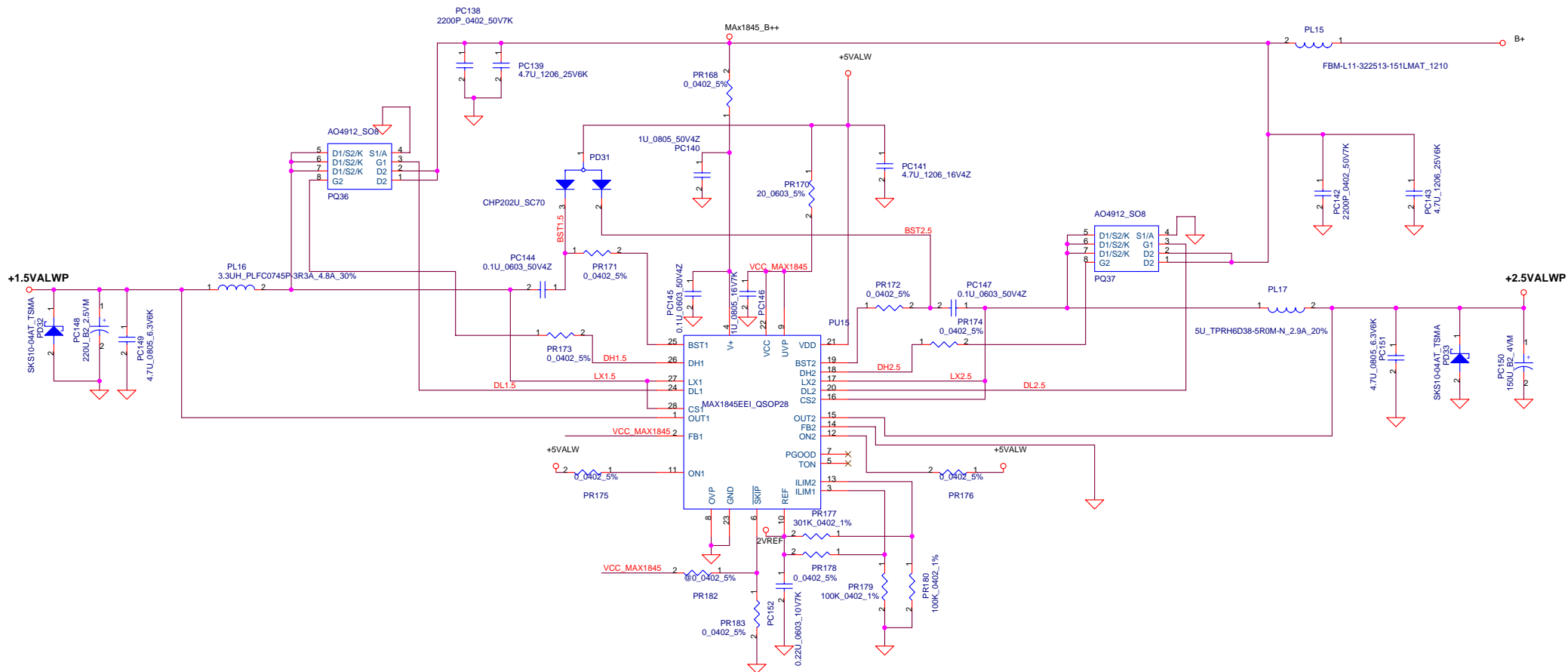

1.5VALWP/+2.5VALWP

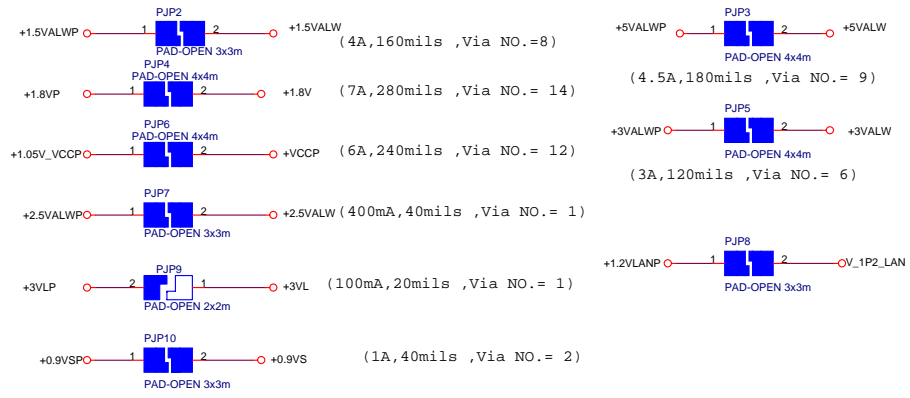

THIS SHEET OF ENGINEERING DRAWING IS THE PROPRIETARY PROPERTY OF COMPAL ELECTRONICS, INC. AND CONTAINS TRADE SECRET INFORMATION. THIS SHEET MAY NOT BE TRANSFERRED FROM THE CUSTODY OF THE COMPETENT DIVISION OF R&D DEPARTMENT EXCEPT AS AUTHORIZED BY COMPAL ELECTRONICS, INC. NEITHER THIS SHEET NOR THE INFORMATION IT CONTAINS MAY BE USED BY OR DISCLOSED TO ANY THIRD PARTY WITHOUT PRIOR WRITTEN CONSENT OF COMPAL ELECTRONICS, INC.

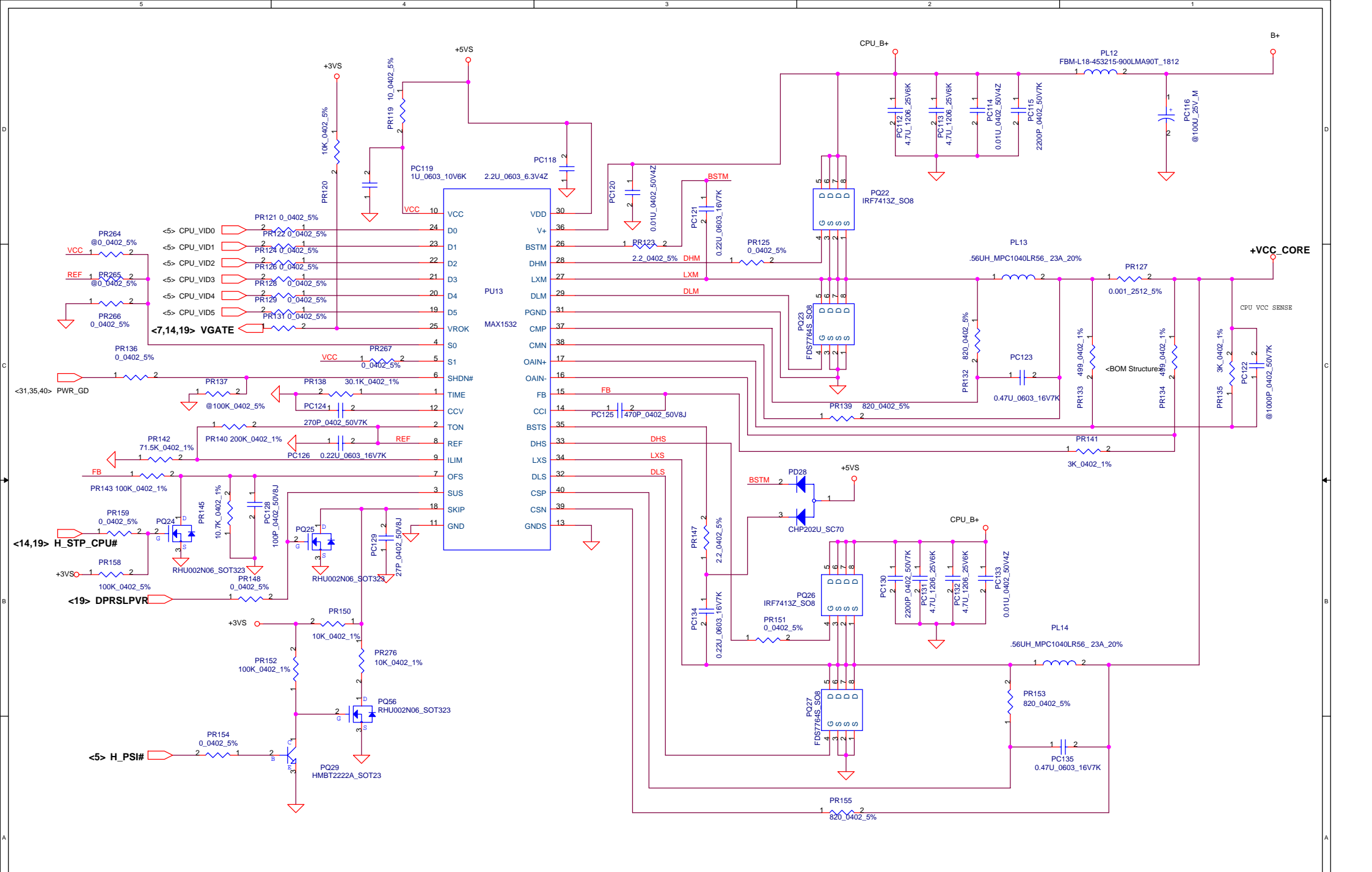

Compal Electronics, Inc.	
Title	+CPU_CORE
Revision	0.5
Date	Thursday, September 09, 2004
Sheet	43 of 47

THIS SHEET OF ENGINEERING DRAWING IS THE PROPRIETARY PROPERTY OF COMPAL ELECTRONICS, INC. AND CONTAINS TRADE SECRET INFORMATION. THIS SHEET MAY NOT BE TRANSFERRED FROM THE CUSTODY OF THE COMPETENT DIVISION DEPARTMENT EXCEPT AS AUTHORIZED BY COMPAL ELECTRONICS, INC. NEITHER THIS SHEET NOR THE INFORMATION IT CONTAINS MAY BE USED BY OR DISCLOSED TO ANY THIRD PARTY WITHOUT PRIOR WRITTEN CONSENT OF COMPAL ELECTRONICS, INC.

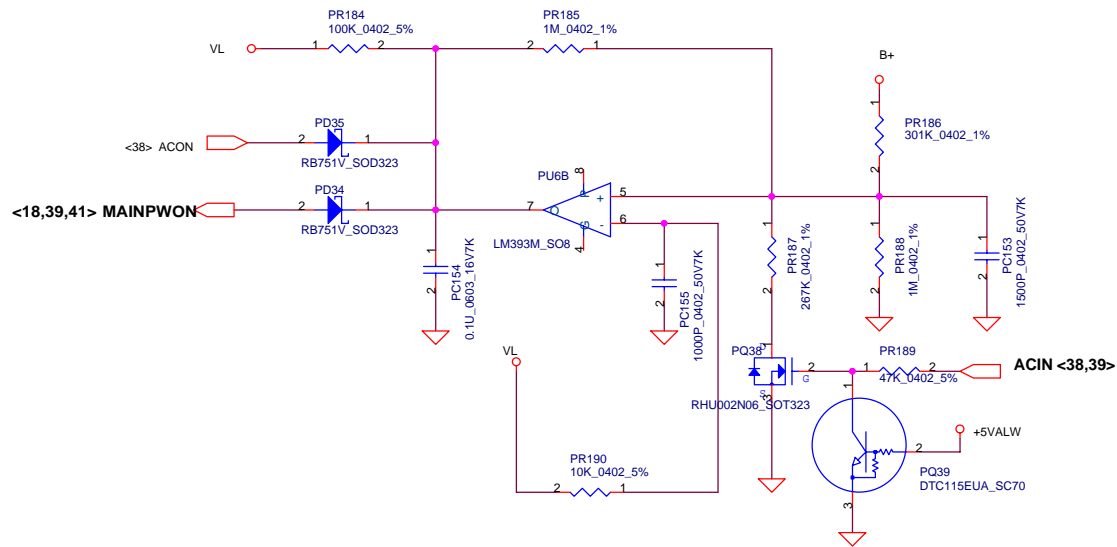
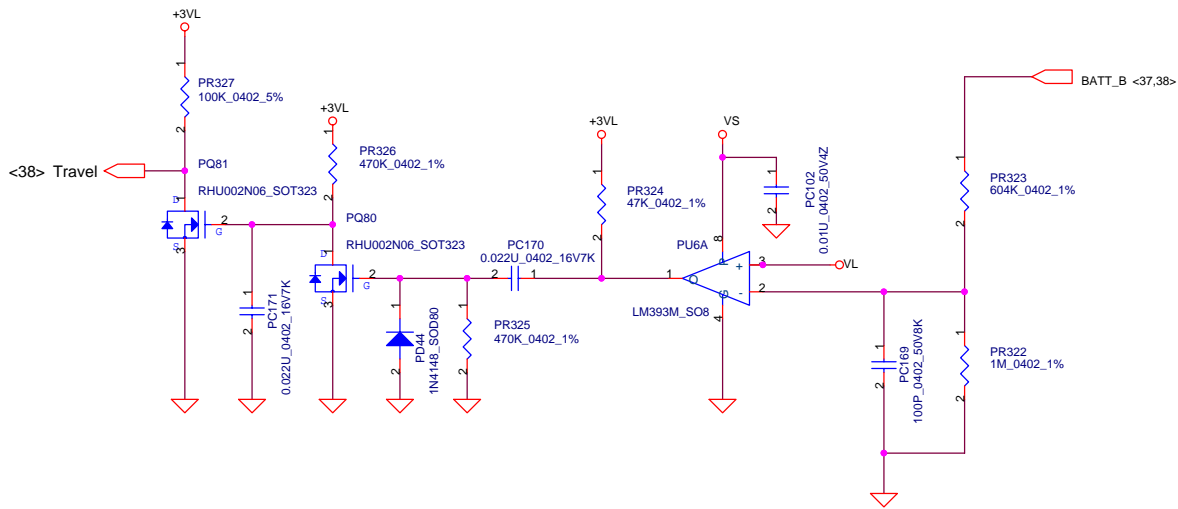

Compal Electronics, Inc.	
Title	BATT OVP
Revision	0.5
Date	Thursday, September 09, 2004
Sheet	44 of 47

THIS SHEET OF ENGINEERING DRAWING IS THE PROPRIETARY PROPERTY OF COMPAL ELECTRONICS, INC. AND CONTAINS CONFIDENTIAL AND TRADE SECRET INFORMATION. THIS SHEET MAY NOT BE TRANSFERRED FROM THE CUSTODY OF THE COMPETENT DIVISION OF R&D DEPARTMENT EXCEPT AS AUTHORIZED BY COMPAL ELECTRONICS, INC. NEITHER THIS SHEET NOR THE INFORMATION IT CONTAINS MAY BE USED BY OR DISCLOSED TO ANY THIRD PARTY WITHOUT PRIOR WRITTEN CONSENT OF COMPAL ELECTRONICS, INC.

Version Change List (P. I. R. List) for Power Circuit

Item	Page#	Title	Date	Request Owner	Issue Description	Solution Description	Rev.
1	39	12VALWP	03/3/2004 (DB2)	HP	remove 12V	delete PQ11,PC54,PR55,PC42,PR52,PD16,PC41,PR51	DB2
2	41	+1.2VLANP	03/3/2004 (DB2)	Compal	1.2VLANP rise plus voltage	change the Vref form 2.5VREF to 2VREF, and change PR104 form 107k_0603 to 100k_0402, PR105 form 100k_0402 to 150k_0402	DB2
3	44	BATT_OVP	03/3/2004 (DB2)	Compal	For BATT_OVP issue	add PC157,PC158 change PR241 from 20k_0402 to 499k_0402, PR243 from 40.2k_0603 to 402k_0402 , PR244 from 453k_00603 to 4499k_0402, PR251 from 20k_0402 to 499k_0402.	DB2
4	41	+1.2VLANP	03/3/2004 (DB2)	Compal	For ME issue	Change PC97,PC93 from 22u_1210 to 22u_1206	DB2
5	38	CHARGER	03/3/2004 (DB2)	Compal	For Charger issue	Change PC27 from 0.1u_0402 to 1u_0603	DB2
6	38	CHARGER	03/3/2004 (DB2)	HP	For SYSTEM OCP function issue	Delete PR263,PR274 . add PUL7,PR280,PR281,PR282,PR283,PC159.	DB2
7	38	CHARGER	03/19/2004 (DB2)	HP	For support that Main Battery is 4 cell pack (4S).	add PQ60,PQ61,PQ62,PR284,PR285,PR286,PR287	DB2
8	38	CHARGER	04/20/2004	HP	To drop the 4 cell battery design.	delete PQ60,PQ62,PR284,PR285,PR287	SI
9	42	1.5VALW/2.5VALW	04/20/2004	Compal	For +1.5VS/+2.5VS peak current issue	Change PL16 from 5uF to 3.3uF PLC0745-3R3A Change PR177 from 100k to 301k Change PR178 from 100K to 0 ohm	SI
10	39	3.3VALW/5VALW	04/28/2004	HP	remove 12V	Change PU7 from MAX1902 to MAX1999 delete PD19,PD20,PR58,PR61,PR63,PR64,PR66,PR59. add PR294,PR295,PR296,PR287,PR288.	SI
11	38	CHARGER	05/13/2004	Compal	add B+ soft start resister.	Add PR294,PR295,PR296	SI
12	38	CHARGER	07/5/2004	HP	For MAX1538 5ms issue	Add PUI8,PQ62,PQ65,PD41,PR299, PR300,PR301,PR302,PR304,PR305,PC166	SI1-B
13	38	CHARGER	07/5/2004	HP	Add HP common logic solution	Add PUI9,PQ68,PQ69,PR306	SI1-B
14	39	3.3VALW/5VALW	07/5/2004	HP	For S5 POWER consumption issue	Add PQ70,PQ71,PR314	SI1-B
15	38	CHARGER	09/1/2004	HP	remove AC OCP	delete PR249	SI2
16	38	CHARGER	09/1/2004	Compal	To improve S5 POWER consumption	Add PQ73,PQ74,PQ75,PR316,PR317,PR318,PR319,PC167	SI2

Compal Electronics, Inc.			
Changed-List History-1			
Size	Document Number	Rev	
	LA-2211	0.5	
Date:	Thursday, September 09, 2004	Sheet	45 of 47

Version Change List (P. I. R. List) for EE Circuit

Item	Page#	Title	Date	Request Owner	Issue Description	Solution Description	Cut-In Date
1	26	AGND	03/22/2004 (DB2)	HP	Link AGND and GND with capacitor	changeR460,R461,R462,R463 from 0_0402_5% to C563,C564,C565,C566 0.1U_0402_16V4Z	DB2(0.3)
2	16	SiI1362	03/22/2004 (DB2)	HP	Follow SiI1362 demo circuit	changeR117 from 100_0402_5% to 1k_0402_5% changeR105 from 300_0402_5% to 1k_0402_5%	DB2(0.3)
3	16	SiI1362	03/23/2004 (DB2)	HP	Follow SiI1362 data sheet recommend	Add R493,R494,R495,R496 300_0402_1% Add C567,C568,C569,C570 0.1U_0402_16V4Z	DB2(0.3)
4	27	Microphone circuit	03/23/2004 (DB2)	HP	To improve frequency response	Add L57,L58,L59,L60,L61 HLC0603CSCCR10JT_0603 Add C571,C572,C573,C574,C575 68P_0402_50V8J	DB2(0.3)
5	32	Trackpoint CONN	03/23/2004 (DB2)	Compal	Change trackpoint connector from pitch1.0mm to 0.5mm	change JP14 from ACES_85203-0802 to ACES_87153-0801L	DB2(0.3)
6	23	V_1P2_LAN	04/01/2004 (DB2)	Compal	V_1P2_LAN ripple over spec	change L8,L29,L30,L32,L33 from 0_0603_5% to BLM11A601S_0603	DB2(0.3)
7	4	ADM1031	04/02/2004 (DB2)	Compal	Can't read DDRII temperature	link Q43 pin1 from GND to Q43 pin2	SI1(0.4)
8	23	ATTN_BTTN#	04/08/2004 (DB2)	HP	Per Broadcom, this signal should be pulled up to +3VS.	Delete R72 layout pad and change R73.1 from GND to +3VS.	SI1(0.4)
9	16	CH7307	04/08/2004 (DB2)	Chrontle	Recommendation from Chrontle.	1. Pin25 VSWING for CH7307 should be added 1.2K ohm to GND. 2. Pin 26, 27 should be GND as 10K ohm. 3. Pin3 AS should be pull up as 1K ohm.	SI1(0.4)
10	29,33	SER_SHD	04/08/2004 (DB2)	HP	Add active high signal SER_SHD to GPIO47 on U8 pin 31 that connects to pin 80 on docking connector JP30B. Add Pull down to this signal. This is used to control serial port transceiver in dock.		SI1(0.4)
11	34	PWR on fail	04/19/2004 (DB2)	Compal	System can't boot reliably.	1. Change Q15 from SI2301 to SI2306. 2. Change Q15.2 control signal from SLP_S3 to RUNON. 3. Change R139 from 100K_0402_5% to 330K_0402_5%.	SI1(0.4)
12	29	MAX3243	04/28/2004 (DB2)	Compal	Delete COM port components.	Delete U33,C558,C559,C561,C560,C562,R468,RP50.	SI1(0.4)
13	9	White screen	04/28/2004 (DB2)	Compal	LCD has white screen when system power on or resume from S3/S4.	1. Exchange U35.3 and U35.5 2. Add a 2.2K_0402_5% pull down resistor on U35.2	SI1(0.4)
14	14,19 23,24	LAN PWR down	04/29/2004 (DB2)	HP	Support LAN controller power down feature when LAN cable do not installed.	1. Delete R499 10K_0402_5%. 2. Add R502,R505,R507 0_0402_5%. 3. Delete R15 4.7K_0402_5%. 4. Add U36,U37 SN74LVC1G17DBVR. 5. Add Q54 2N7002. 6. Add C576,C577 0.1U_0402_16V4Z. 7. Add D32 RB751V. 8. Add R503 100K_0402_5%. 9. Add R504 120K_0402_5%. 10. Add R506 10K_0402_5%.	SI1(0.4)

Compal Electronics, Inc.		
Title		
Changed-List EE History-1		
Size	Document Number	Rev
	LA-2211	0.6
Date:	Thursday, September 09, 2004	Sheet 46 of 48

Version Change List (P. I. R. List) for EE Circuit

Item	Page#	Title	Date	Request Owner	Issue Description	Solution Description	Cut-In Date
15	21	TI Flash media IO	04/30/2004 (DB2)	HP	Solve TI Flash media IO work around circuit.	Add D33,D34 RB751V.	SI1(0.4)
16	19	LANLINK_STATUS#	04/30/2004 (DB2)	HP	Change this signal from pin M3 of U26B to pin C25 of U26C.	1. Add R508 10K_0402_5%. 2. Add Q55 2N7002.	SI1(0.4)
17	21,22	Change power rail	05/12/2004 (DB2)	HP	PCMCIA interface don't support S3 or S5 wake up feature.	Change all of components power rail to main power plane.	SI1(0.4)
18	28	USB+PWR switcher	05/21/2004 (DB2)	Compal	Change USB power switcher from MIC2044 to TPS2330.		SI1(0.4)
19	27	Microphone pre-amp	05/26/2004 (DB2)	HP	Per HP's requirement change microphone pre-amp from MAX4492 to TLV2464A.		SI1(0.4)
20	21,22	Change power rail	05/27/2004 (DB2)	HP	Going back and forth for waking up support for PCMCIA interface.	Change all of components power rail to resume power plane.	SI1(0.4)
21	21,22	Change power rail	07/05/2004 (SI1)	HP	PCMCIA interface don't support S3 or S5 wake up feature.	1. Reserved some component layout pads for +3V/+5V. 2. Add R530 and R537 for supportting PCMCIA power rail with main power rail.	SI1-B(0.5)
22	19,31 32,35	S5 power consumption	07/05/2004 (SI1)	HP	To reduce power consumption on S5. The specification is under 50 mW.	1. Add isolation circuit. (R532,R533,D37,D38) 2. Change some component's power rail from +3VALW to +3VL (R223,R218[V_3P3_LAN],U7,RP44,RP43,R65,R28,R27,JP31 RP1,R32,R31,R30,U5,R22,R24,R7)	SI1-B(0.5)
23	28	USB+PWR switcher	07/20/2004 (SI1)	Compal	To solve voltage droop issue when cradle plugged in USB port.	1. Change C582 from 1000pF to 0.1uF. 2. Add C581 0.1uF. 3. Change C102 to 100uF Low ESR capacitor.	SI2(0.6)
24	31	Wrong voltage level on FWP#.	07/22/2004 (SI1)	Compal	To solve wrong voltage on FWP# when system is powered off.	Delete R28.	SI2(0.6)
25	27	OTS#133751	07/22/2004 (SI1)	Compal	When mute is off, the mute button LED remains on (very dim though).	Change R430 from 100K ohm to 10K ohm.	SI2(0.6)
26	18	ICH_RTCRST# timing	07/22/2004 (SI1)	Intel	Intel changed component's value.	1. Change R230 from 180K ohm to 20K ohm. 2. Change C287 from 0.1uF to 1uF.	SI2(0.6)
27	14	R511	08/03/2004 (SI1)	Compal	For supporting CY28442 on SI2.	Delete R511.	SI2(0.6)
28	27	R429, C504	08/03/2004 (SI1)	HP	Follow Lloyd Daniel's suggestion, change R429 to 16.2K ohm and change C504 to 0.22uF.	change R429 to 16.2K ohm and change C504 to 0.22uF.	SI2(0.6)
29	30	Power LED active error.	08/03/2004 (SI1)	Compal	Swap D41.1 with D41.4 for solving LED active error on SI1-B unit.		SI2(0.6)
30	16,26 32	Modify EMI solution	08/03/2004 (SI1)	Compal		1. Add FBM-L11-201209-221LMAT on L62 and delete R466. 2. Add 0.1u (C586) / 68p (C587) capacitors at B+_LCD. 3. Add CHB2012U121 on L36. 4. Remove CPL-CP7	SI2(0.6)
31	30	Delete sleep button function	08/10/2004 (SI1)	HP	Sleep LED is no longer required.	Delete D40 & R261.	SI2(0.6)
32	30	Add additional R & LED for CAP. function	08/10/2004 (SI1)	Compal	For solving CAP LED bright issue. This requirement was coming from ME team.	1. Add R541 150 ohm. 2. Add green LED 17-21SYGC/S530-E1/TR8.	SI2(0.6)

Compal Electronics, Inc.		
Changed-List EE History-2		
Size	Document Number	Rev
	LA-2211	0.6
Date:	Thursday, September 09, 2004	Sheet 47 of 48

Version Change List (P. I. R. List) for EE Circuit

Item	Page#	Title	Date	Request Owner	Issue Description	Solution Description	Cut-In Date
33	30	Power Button	08/10/2004 (SI1)	Compal	Change powr button from 2-way to 1-way.	From SS056-Pt213BET-PA2 to SS607-212N-FEEG1T.	SI2(0.6)
34	19	OTS#137561	08/19/2004 (SI1)	Compal	I found this issue was caused by ICH_PCIE_WAKE# signal generated again. Because V_3P3_LAN disappeared before +3VALW under battery mod. This is wrong.	<ol style="list-style-type: none"> 1. Change R532 from 10K ohm to 1K ohm. 2. Delete D37. 3. Add a additional MOS Q71 (BSS138). 4. Connection Q71.2 with V_3P3_LAN. 5. Connection Q71.3 with D37.1. 6. Connection Q71.1 with D37.2. 	SI2(0.6)
35	15	RGB rise/fall time.	08/23/2004 (SI1)	Compal	RGB rise/fall time out of specification issue.	Short L54,L55,L56.	SI2(0.6)
36	18	RTC Accuracy	08/27/2004 (SI1)	Compal	To improve RTC accuracy.	<ol style="list-style-type: none"> 1. Change Y4 to 32.768 KHz +-10 ppm. 2. Change C516 and C528 to 18pF. 	SI2(0.6)
37	16	DVI CKT	08/31/2004 (SI1)	HP	Remove any components that associate with Silicon Image controller for DVI.		SI2(0.6)
38	4	ADM1032	09/02/2004 (SI1)	Compal	Change thermal sensor to ADM1032 and reserve a thermal sensor CKT (MAX6646) on page 8.		SI2(0.6)

Вы скачали этот файл с сайта «Сайт радиолюбителей»



Другие разделы сайта

Раздел БИБЛИОТЕКА

Книги для и журналы радиолюбителям

<http://radio-uchebnik.ru/library/>

Раздел РАДИОСХЕМЫ

Различные схемы как для начинающих так и для профессионалов:

Схемы бытовой техники, телевизоров, мониторов, автомагнитол, музыкальных центров, и для самостоятельной сборки

<http://radio-uchebnik.ru/shem/>

Раздел ФАЙЛОВОЕ ХРАНИЛИЩЕ

Различные файлы: Даташиты, схемы, прошивки и так далее

<http://radio-uchebnik.ru/downfiles/>

Раздел РАДИОКОМПАС

Если Вы занимаетесь ремонтом электроники на профессиональном уровне- то Вы можете сообщить о себе.

<http://radio-uchebnik.ru/radiomap/>

Раздел ДОСКА ОБЪЯВЛЕНИЙ

Здесь Вы можете разместить бесплатное объявление сроком до 120 дней (только радиотематика!!)

<http://radio-uchebnik.ru/ads/>

Раздел СПРАВОЧНИК ПО МИКРОСХЕМАМ

Справочные данные на микросхемы импортного и отечественного производства

<http://radio-uchebnik.ru/microbase/>

Раздел СТАТЬИ

Различные статьи радиолюбительской (и не только) тематики: секреты телемастера, практическая электроника, альтернативная энергия, расчеты по электронике, электронные устройства и так далее

<http://radio-uchebnik.ru/txt/>

ФОРУМ НАШЕГО САЙТА

<http://radio-uchebnik.ru/forum/>