

# QL6 BLOCK DIAGRAM

- LAYER 1 : TOP
- LAYER 2 : SGND
- LAYER 3 : IN1
- LAYER 4 : SGND
- LAYER 5 : SVCC
- LAYER 6 : IN2
- LAYER 7 : SGND
- LAYER 8 : BOT

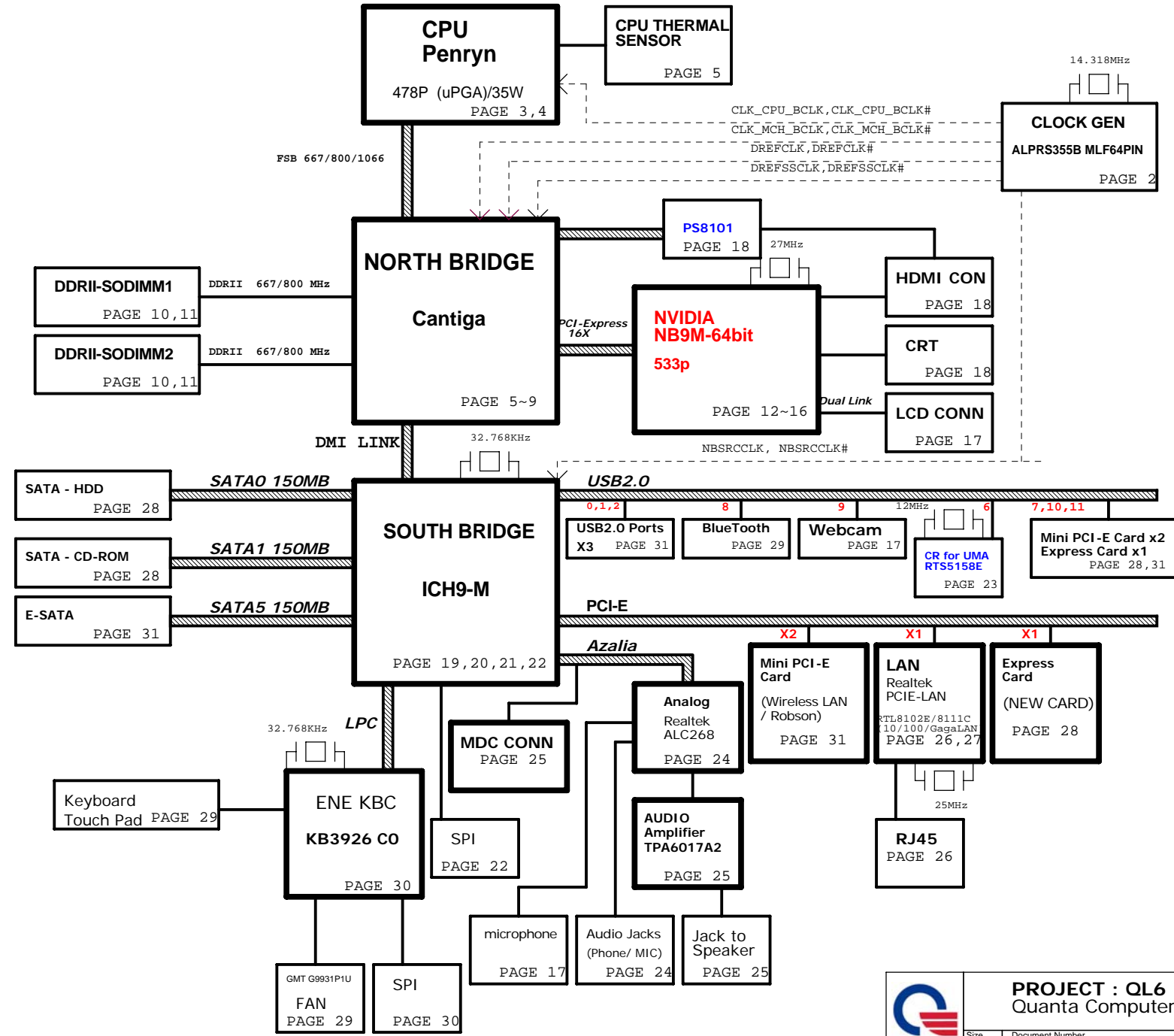

- SYSTEM CHARGER(ISL6251AHAZ-T) PAGE 32
- SYSTEM POWER ISL6237IRZ-T PAGE 33
- DDR II SMD DR\_VTERM 1.8V/1.8VSUS(TPS51116REGR) PAGE 37
- VCCP +1.5V AND GMCH 1.05V(RT8204) PAGE 34
- VGACORE(1.025V)Oz8118 PAGE 36
- CPU CORE ISL6266A PAGE 35

	<b>PROJECT : QL6</b>		Rev 2A
	Quanta Computer Inc.		
Size Custom	Document Number	Block Diagram	
Date: Tuesday, February 26, 2008	Sheet 1	of 40	

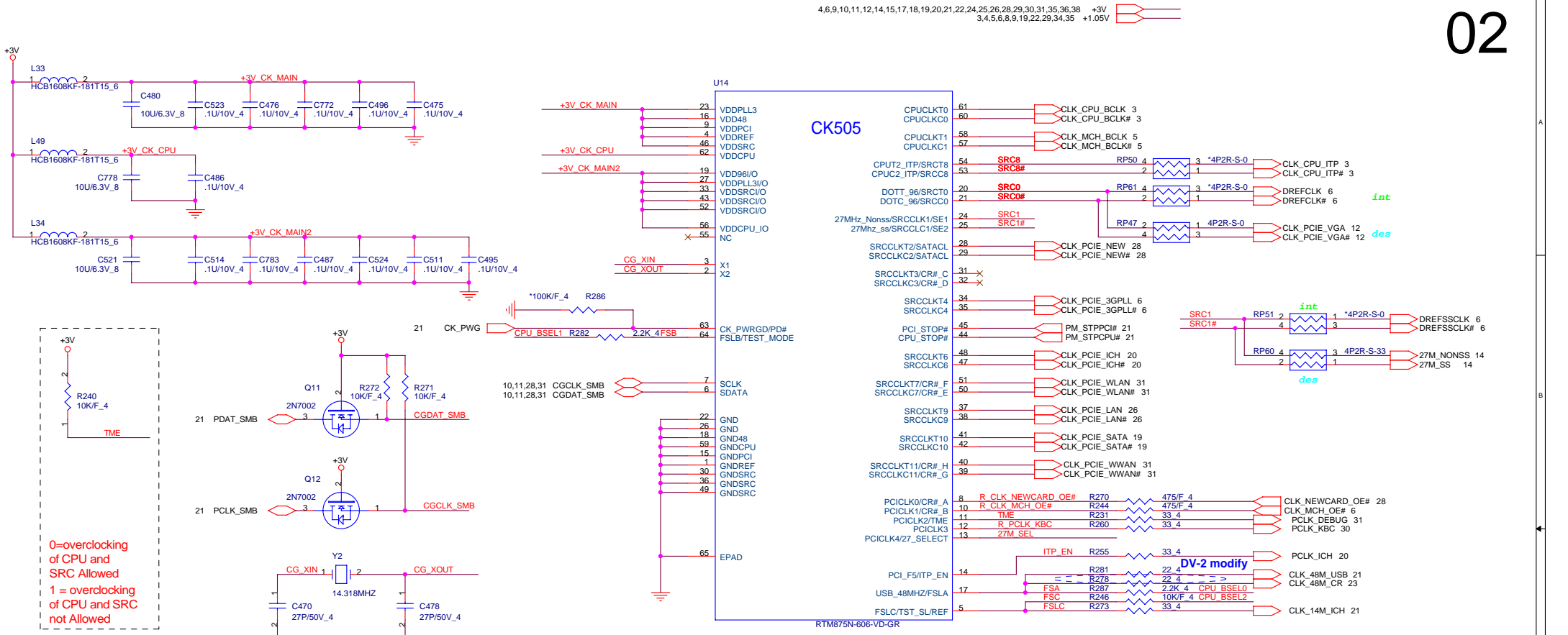

0=overlocking of CPU and SRC Allowed  
 1 = overlocking of CPU and SRC not Allowed

0=UMA  
 1 = External VGA

Enable ITP CLK

27M_SEL PIN13	PIN20	PIN21	PIN24	PIN25
0=UMA	DOT96T	DOT96C	SRCT1/LCDT_100	SRCT1/LCDT_100
1 = External VGA	SRCT0	SRCC0	27Mout-NSS	27Mout-SS

### CK505 QFN64

ICS ICS9LPRS355BKLF ALPRS355000  
 Siligo SLG8SP513VTR AL8SP513000  
 Realtek RTM875N-606-VD-GR AL000875000

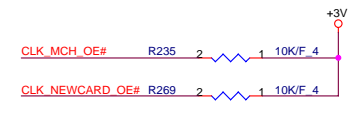

#### CPU Clock select

#### DV-2 modify

FSC	FSB	FSA	CPU	SRC	PCI
1	0	1	100	100	33
0	0	1	133	100	33
0	1	1	166	100	33
0	1	0	200	100	33
0	0	0	266	100	33
1	0	0	333	100	33
1	1	0	400	100	33
1	1	1	RSVD	100	33

1k to NB only when XDP is implement, No XDP can use 0 ohm

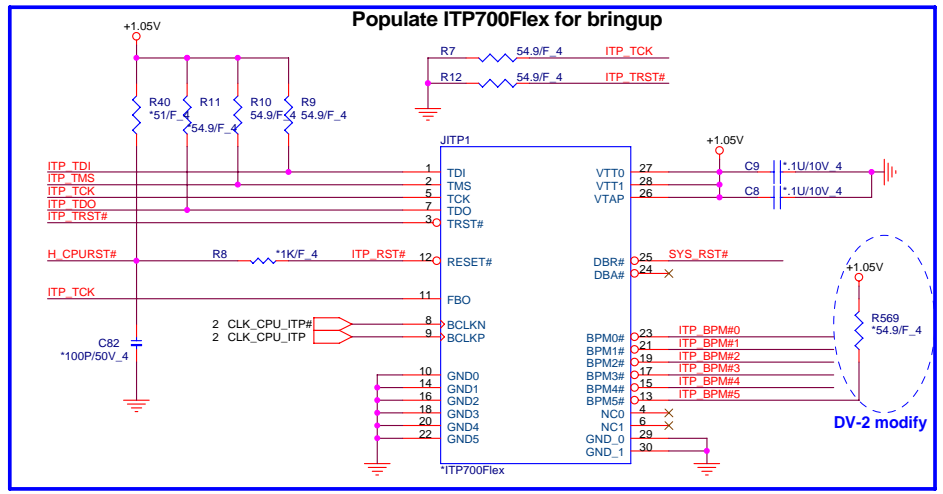
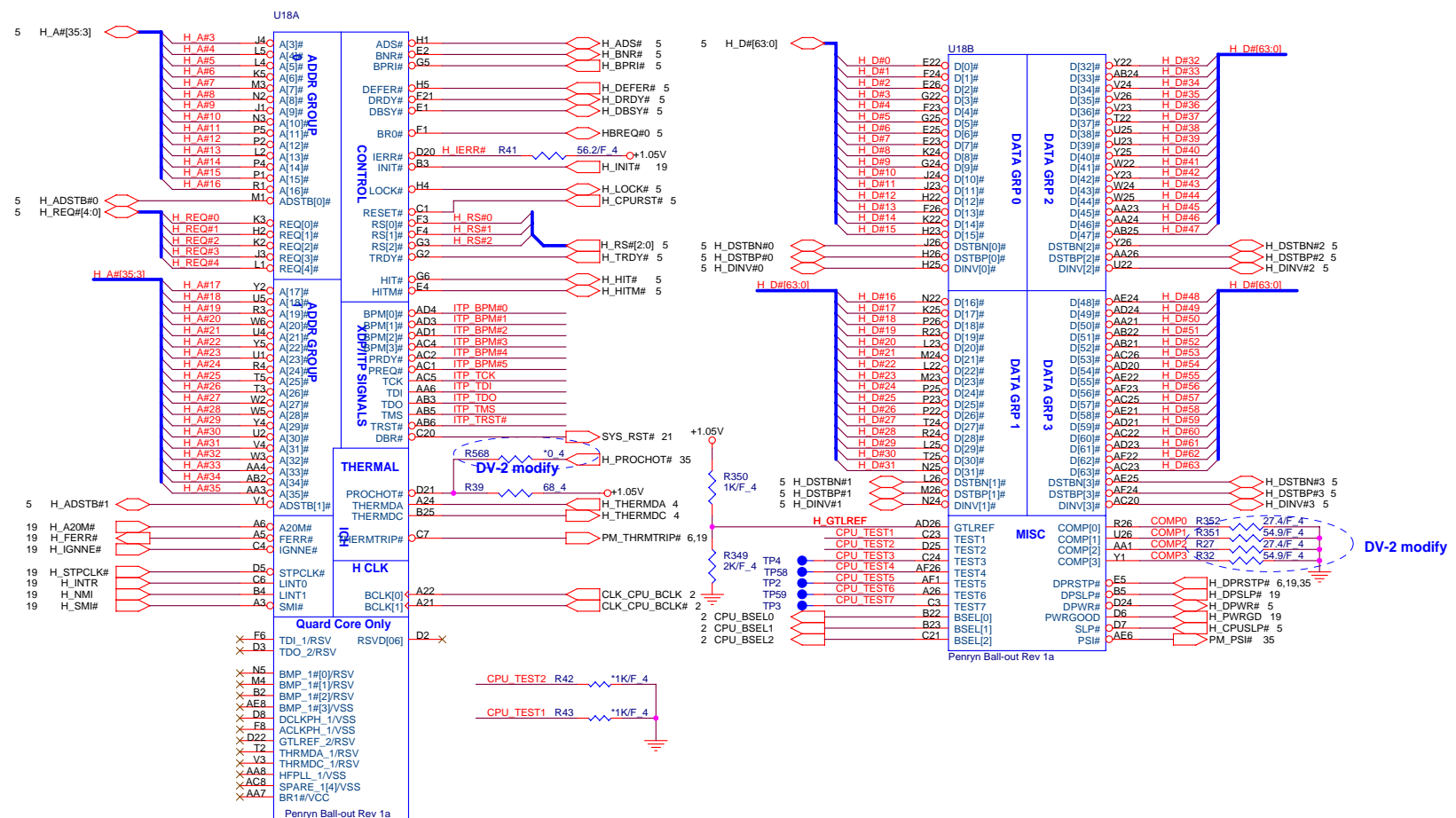

**PROJECT : QL6**  
Quanta Computer Inc.

Size Custom	Document Number <b>Penryn 1/2</b>	Rev 2A
Date: Tuesday, February 26, 2008		
Sheet 3 of 40		

2,6,9,10,11,12,14,15,17,18,19,20,21,22,24,25,26,28,29,30,31,35,36,38 +3V  
2,3,5,6,8,9,19,22,29,34,35 +1.05V  
9,19,20,22,24,25,28,31,34,38 +1.5V  
35 +VCCORE

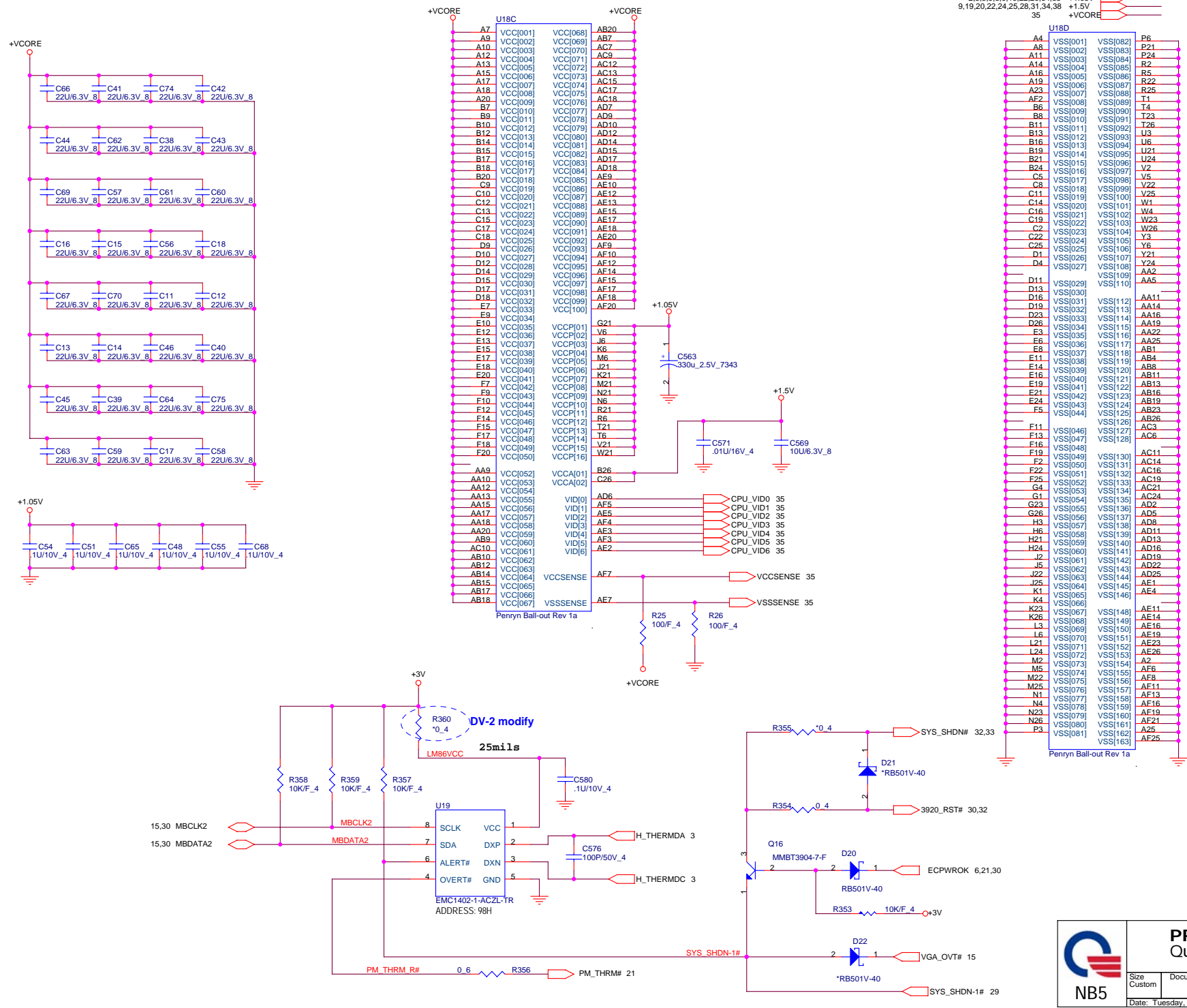

**PROJECT : QL6**  
Quanta Computer Inc.

**NB5**

Size Custom	Document Number	Rev 2A
Penryn & TH Monitor 2/2		
Date: Tuesday, February 26, 2008	Sheet 4 of 40	

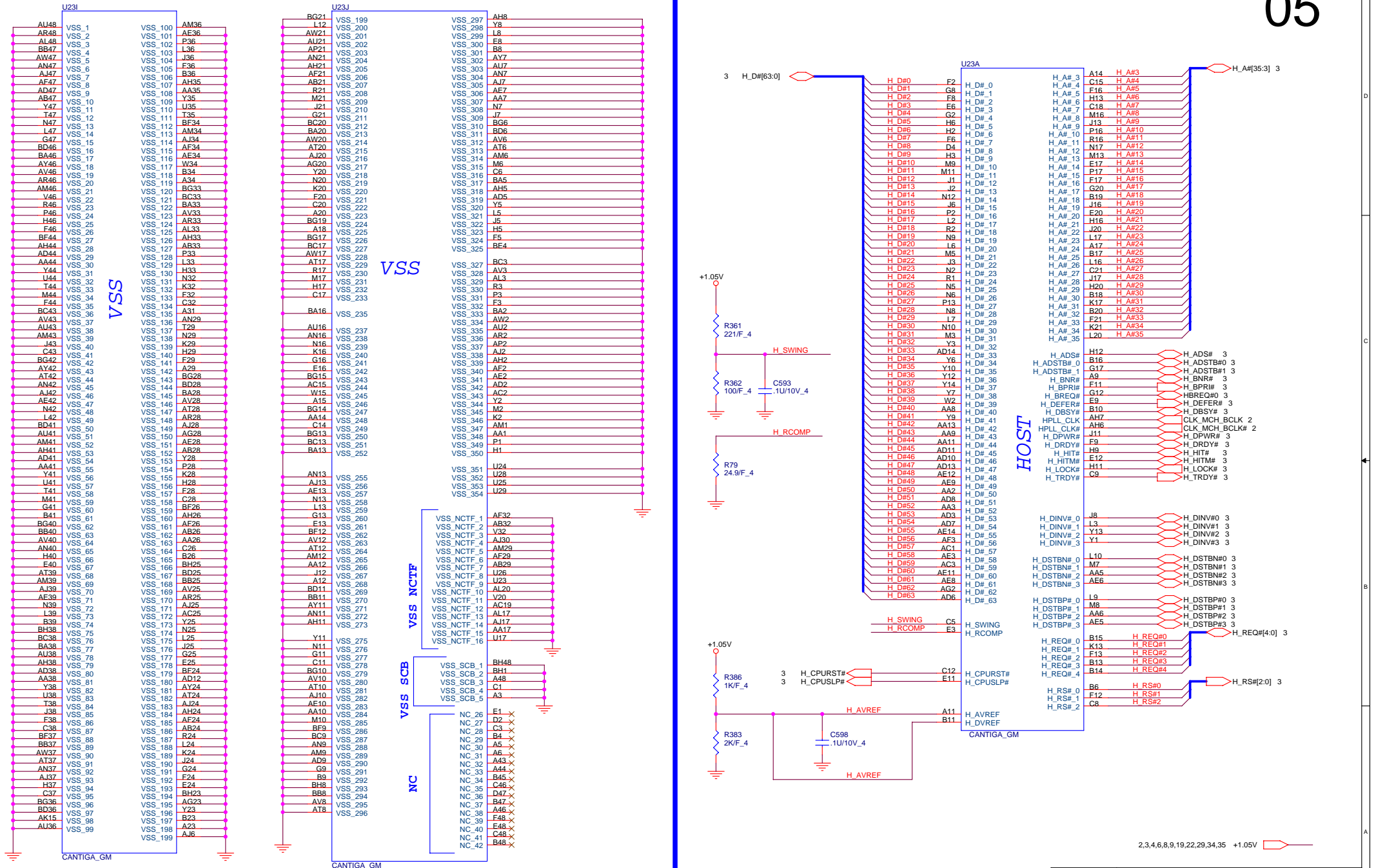



**NB5**

**PROJECT : QL6**  
Quanta Computer Inc.

Size Custom    Document Number  
**Cantiga Host & VSS 1/5**    Rev 2A

Date: Tuesday, February 26, 2008    Sheet 5 of 40

2,4,9,10,11,12,14,15,17,18,19,20,21,22,24,25,26,28,30,31,35,36,38  
 +3V 8,9,10,29,34,37 +1.8VSUS  
 2,3,4,5,8,9,19,22,29,34,35 +1.05V  
 9 +1.05V\_PEG

PEG\_TX#15[0] PEG\_TX#15[0] 12  
 PEG\_TX15[0] PEG\_TX15[0] 12  
 PEG\_RX#15[0] PEG\_RX#15[0] 12  
 PEG\_RX15[0] PEG\_RX15[0] 12

06

MCH\_CFG\_5 DMi2 selection

Low: DMi2  
 High: DMi4 (Default)  
 MCH\_CFG\_16 FSB Dynamic ODT

Low: Dynamic ODT disabled  
 High: Dynamic ODT enabled (Default)  
 MCH\_CFG\_9 PCI Express Graphic Lane

Low: Reverse Lane  
 High: Normal operation(Default)  
 MCH\_CFG\_19 DMI Lane Reversal

MCH\_CFG\_6 iTPM Host Interface  
 Low: iTPM Host Interface enabled  
 High: iTPM Host Interface disabled (Default)  
 MCH\_CFG\_7 Intel (R) Management Engine Crypto

Low: Intel (R) Management Engine Crypto  
 TLS cipher suite with no confidentiality  
 High: Intel (R) Management Engine Crypto  
 TLS cipher suite with no confidentiality (Default)

MCH\_CFG\_10 PCIe Lookback Enable  
 Low: Enabled  
 High: Disabled (Default)  
 MCH\_CFG\_12/13 XOR/ALL/CLOCK Un-gating

MCH\_CFG\_13 MCH\_CFG\_12 Configuration

CFG_0	Reserved
0	0
1	0
0	1
1	1

XOR Mode enabled  
 All-Z Mode enabled  
 Normal operation (Default)

TP30 AL34 ME\_JTAG\_TCK  
 TP26 AK34 ME\_JTAG\_TDI  
 TP24 AN35 ME\_JTAG\_TDO  
 TP23 AM35 ME\_JTAG\_TMS

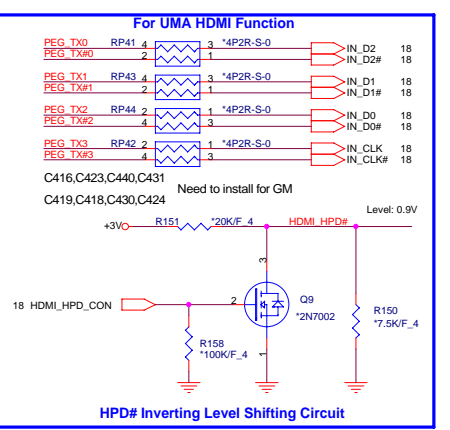
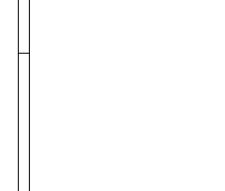
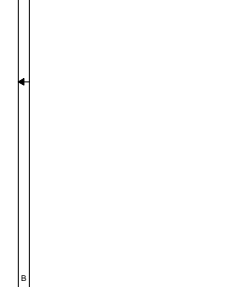
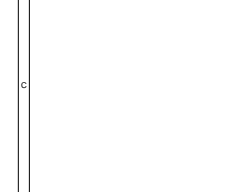
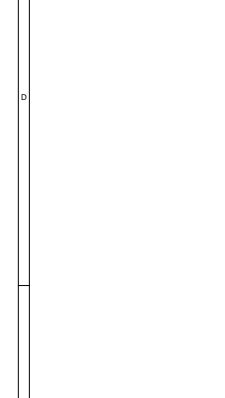
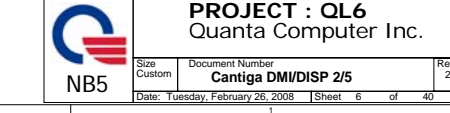
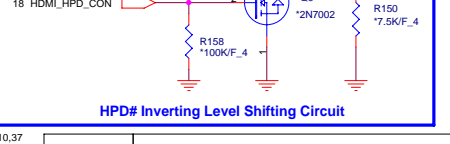
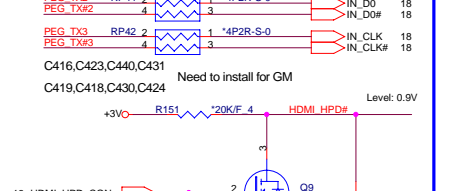
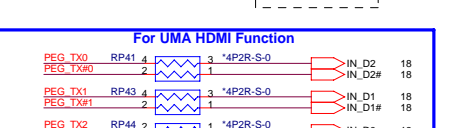
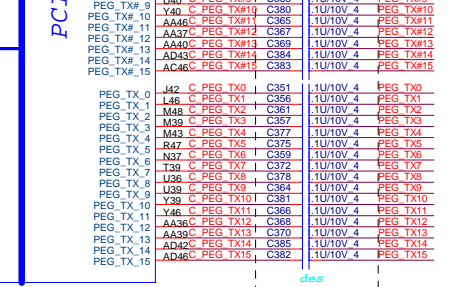
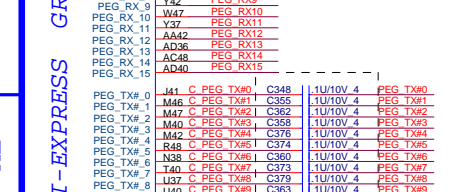
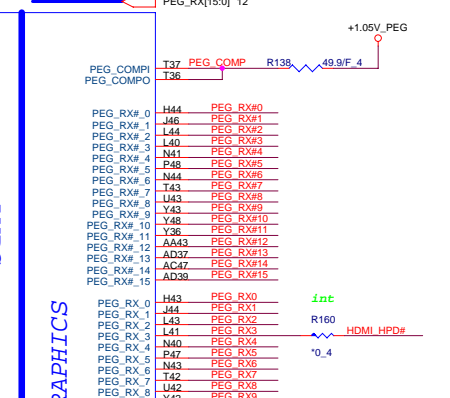
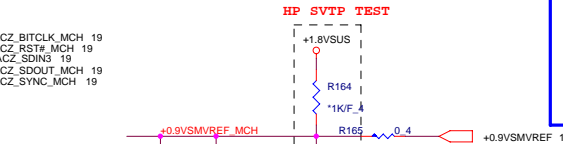
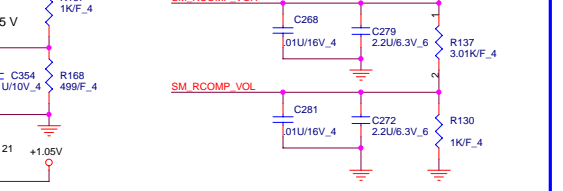
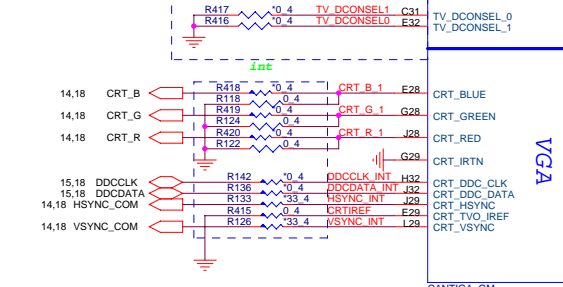
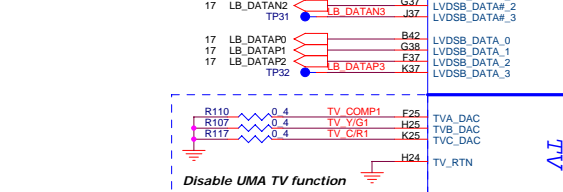
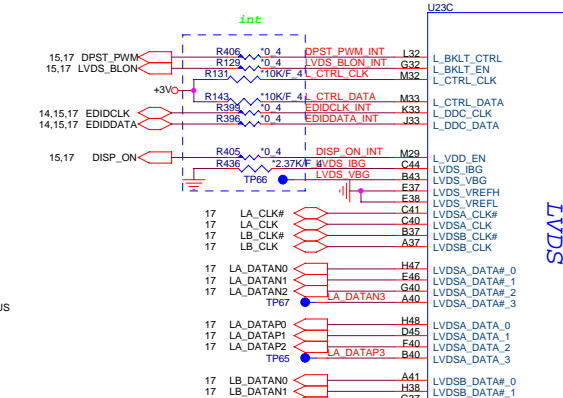
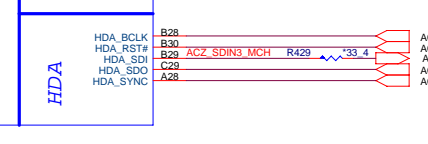
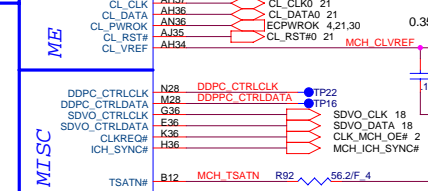
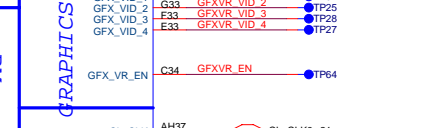
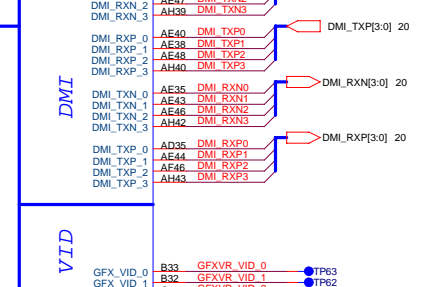
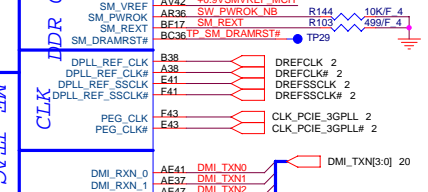
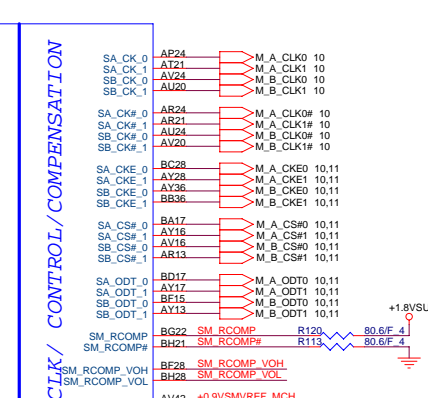
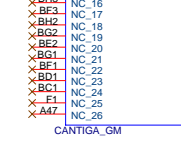
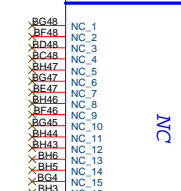
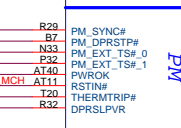
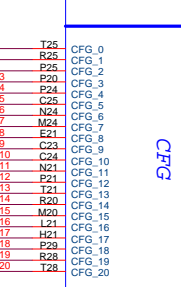
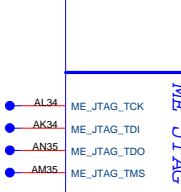
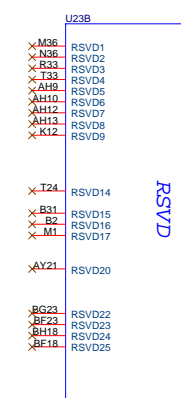
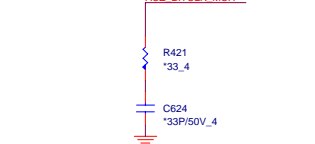
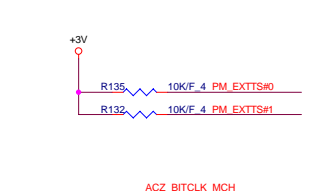
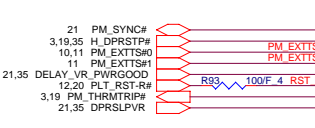
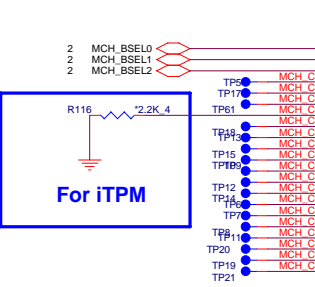

**PROJECT : QL6**  
 Quanta Computer Inc.

Size Custom	Document Number	Rev
	Cantiga DM/DISP 2/5	2A
Date: Tuesday, February 26, 2008	Sheet 6 of 40	



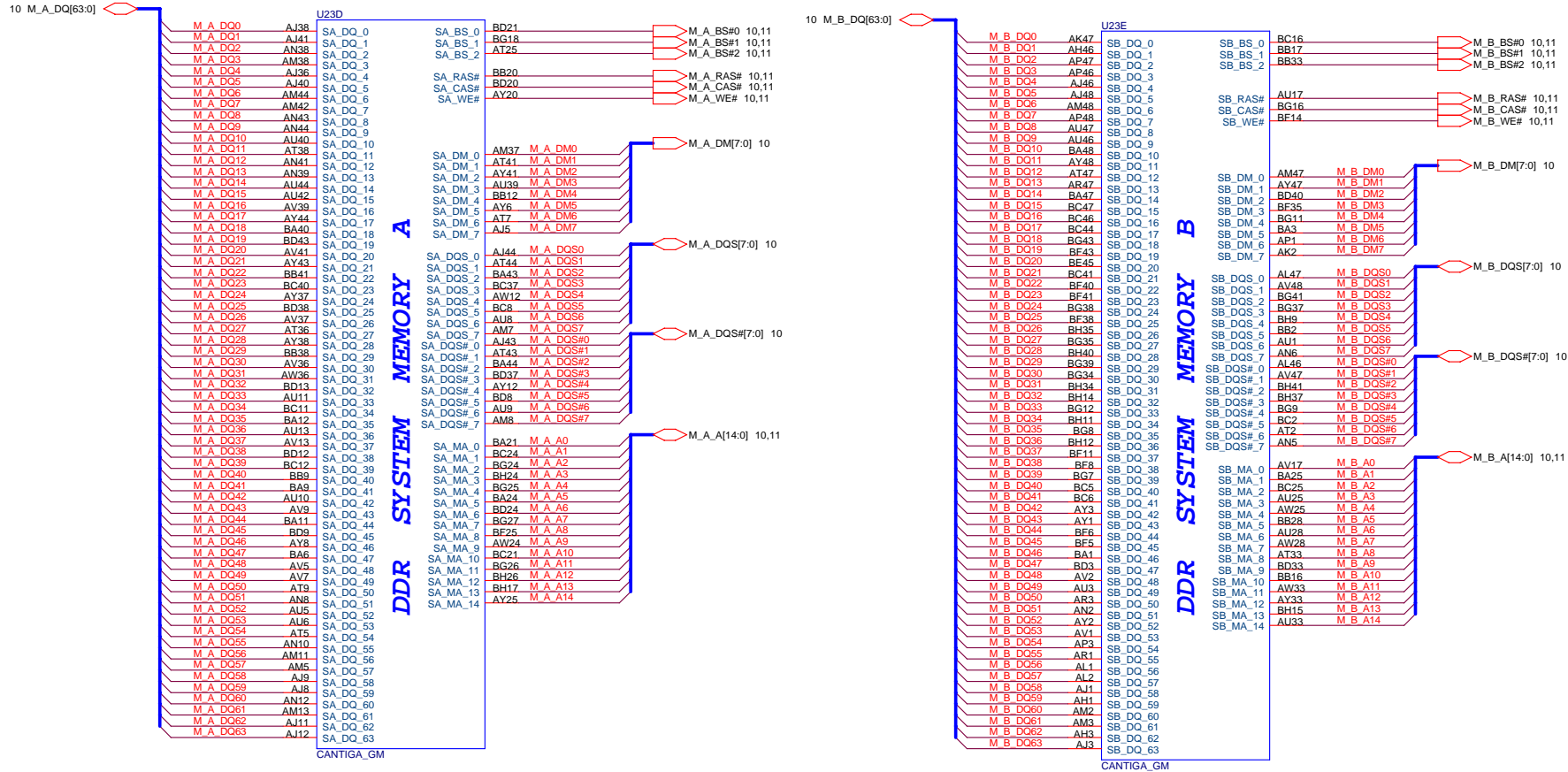

	<b>PROJECT : QL6</b>		Rev 2A
	Quanta Computer Inc.		
	Size Custom	Document Number <b>Cantiga DDR2 3/5</b>	
Date: Tuesday, February 26, 2008		Sheet 7 of 40	

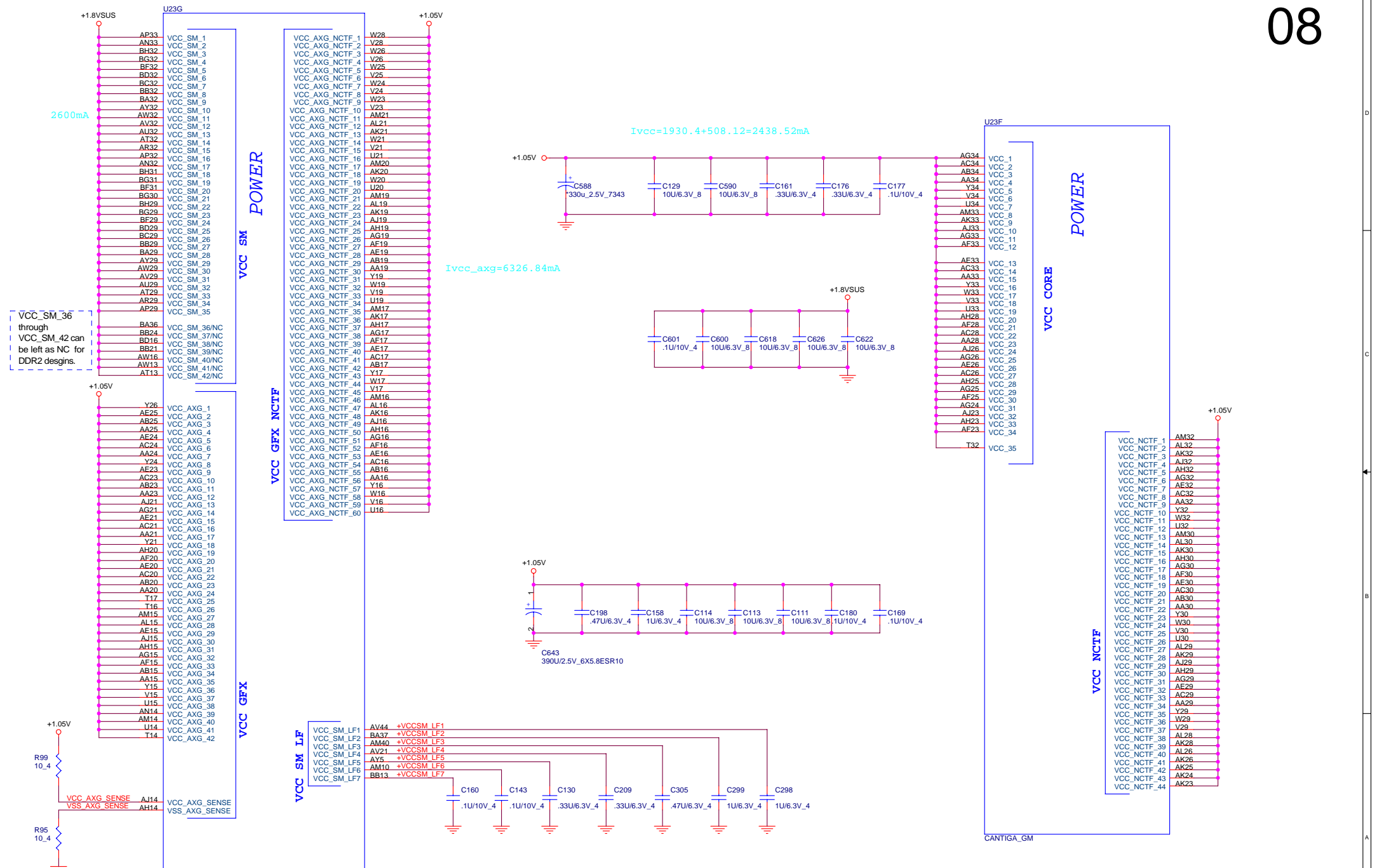

6,9,10,29,34,37 +1.8VSUS  
2,3,4,5,6,9,19,22,29,34,35 +1.05V



	<b>PROJECT : QL6</b>		Rev 2A
	Quanta Computer Inc.		
	Size Custom	Document Number <b>Cantiga Vcc 4/5</b>	
Date: Tuesday, February 26, 2008		Sheet 8 of 40	



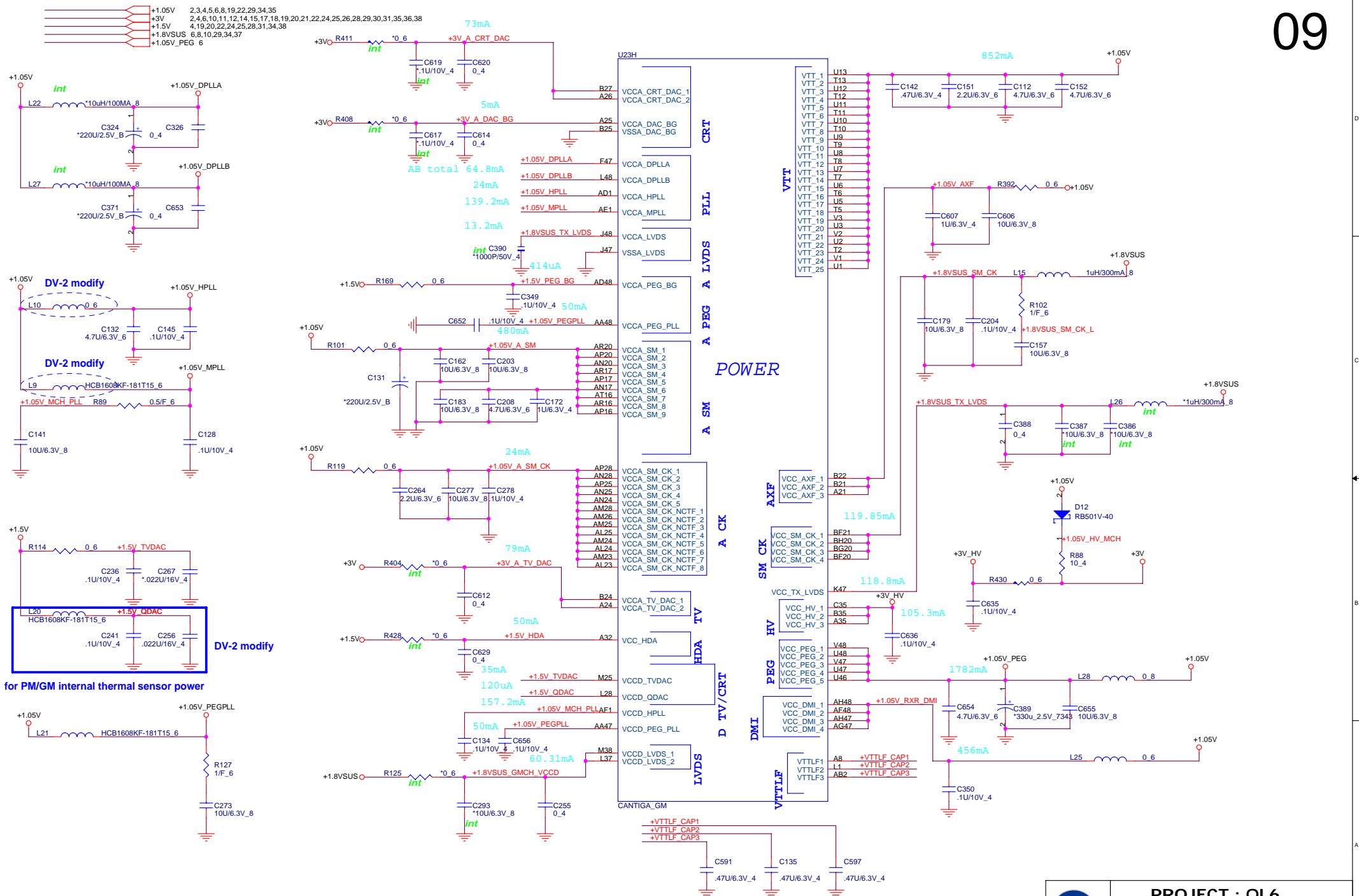

**DV-2 modify**

**DV-2 modify**

**DV-2 modify**

**for PM/GM internal thermal sensor power**

	<b>PROJECT : QL6</b>	
	Quanta Computer Inc.	
	Size Custom	Document Number
Date: Tuesday, February 26, 2008		Sheet 9 of 40

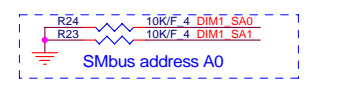
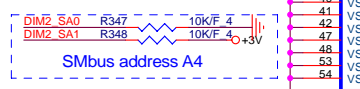
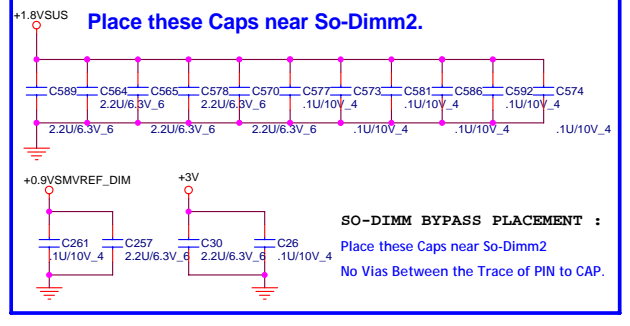
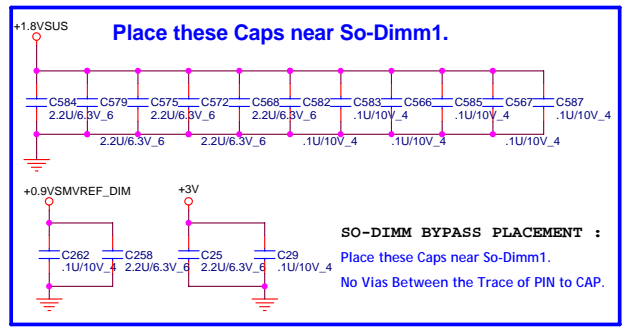
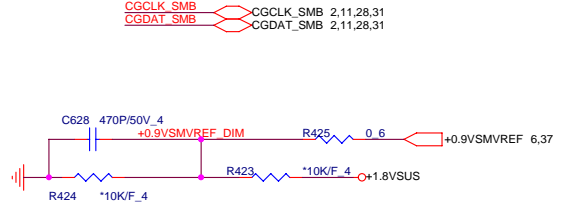
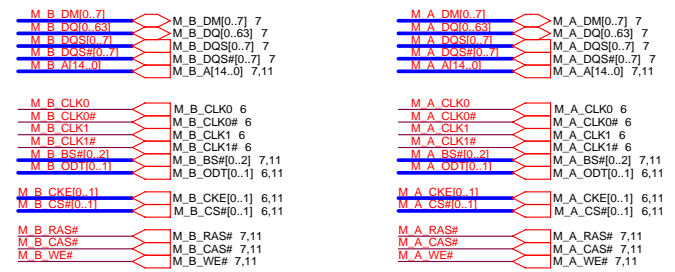
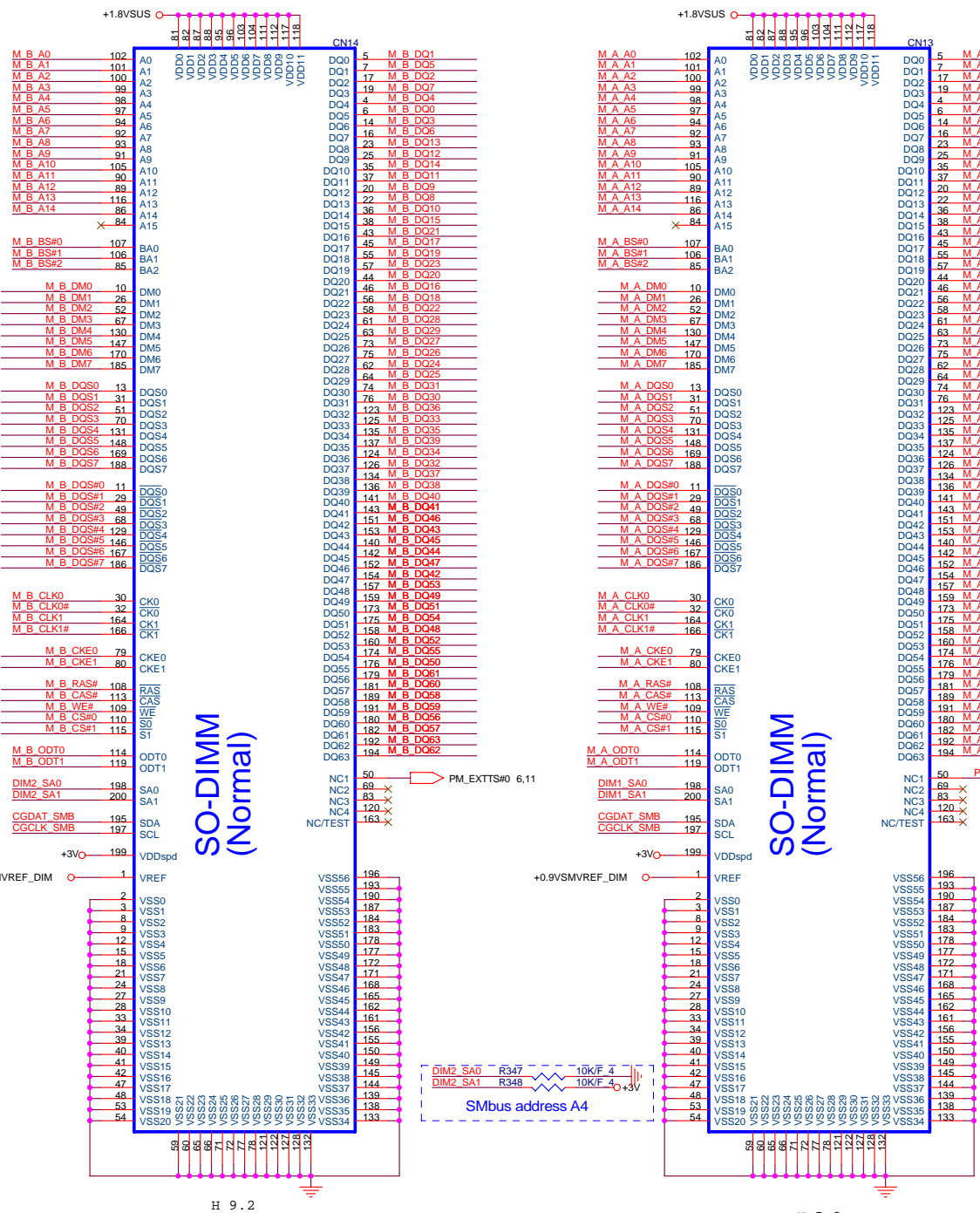

H 9.2

H 5.2

2.4,6,9,11,12,14,15,17,18,19,20,21,22,24,25,26,28,29,30,31,35,36,38 +1.8VSUS +3V

**PROJECT : QL6**  
Quanta Computer Inc.

**NB5**

Size Custom	Document Number	Rev
	<b>DDR2 DIMM</b>	2A
Date: Tuesday, February 26, 2008	Sheet 10 of 40	

# DDRII DUAL CHANNEL A,B.

## DDRII A CHANNEL

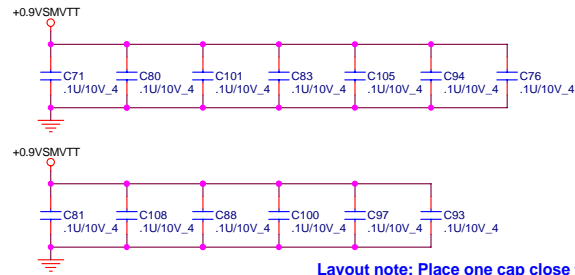

Layout note: Place one cap close to every 2 pullup resistors terminated to SMDDR\_VTERM

## DDRII B CHANNEL

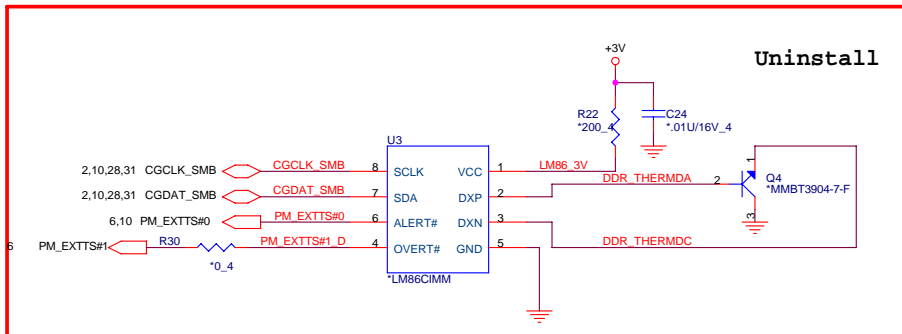
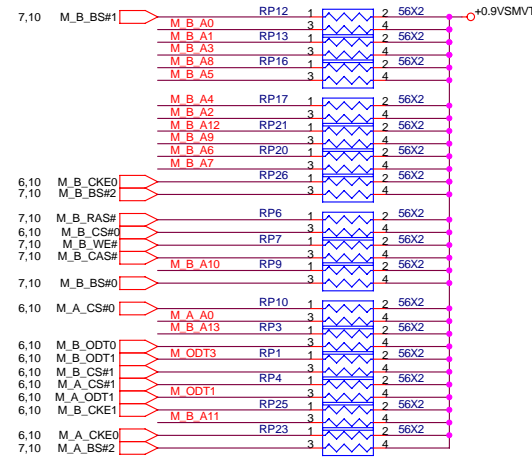
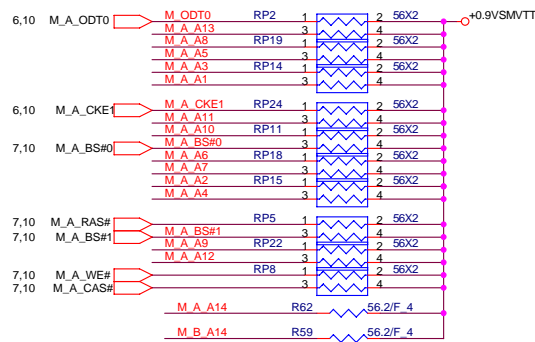
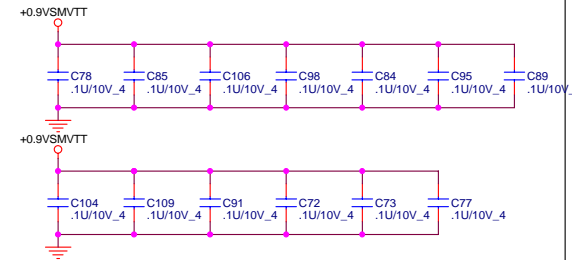

**PROJECT : QL6**  
Quanta Computer Inc.

Size Custom	Document Number <b>DDR2 termination</b>	Rev 2A
Date: Tuesday, February 26, 2008 Sheet 11 of 40		

NB9M-GE (G98)

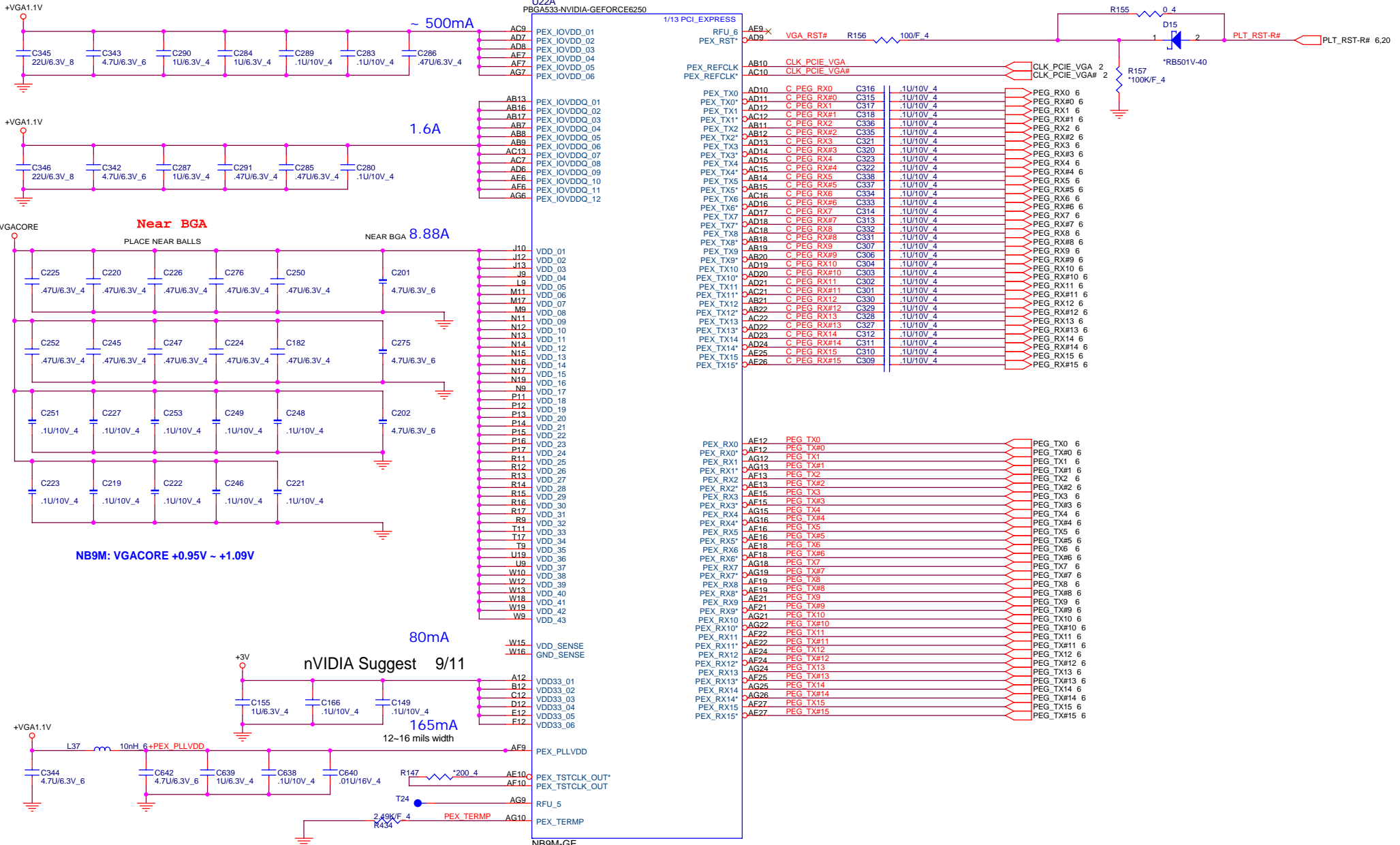

**PROJECT : QL6**  
Quanta Computer Inc.

**NB5**

Size Custom	Document Number <b>NV9X (PCI E I/F) 1/5</b>	Rev 2A
Date: Tuesday, February 26, 2008	Sheet 12 of 40	

1.63A

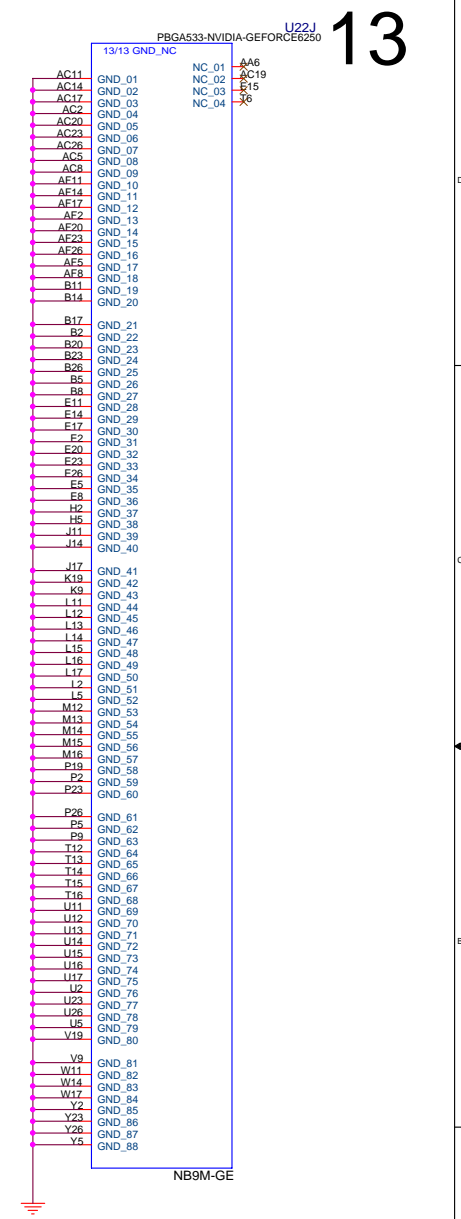
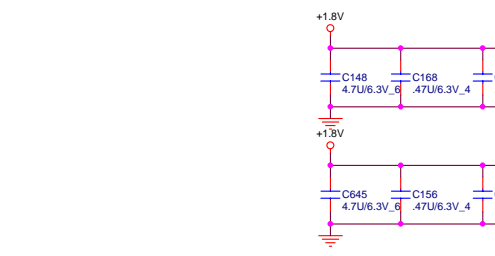
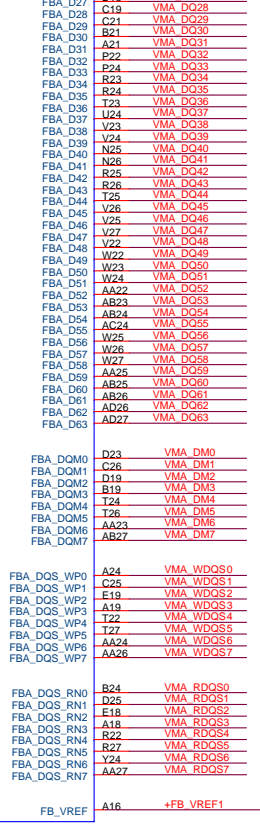
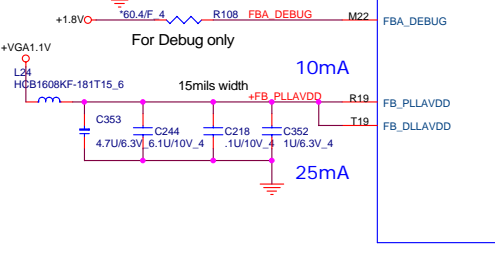
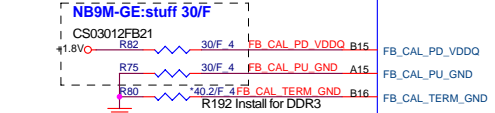
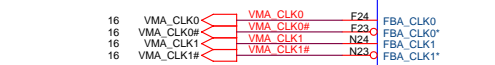
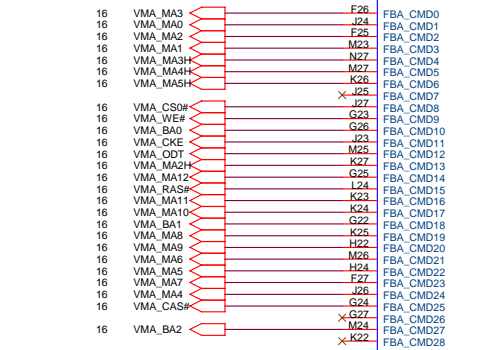
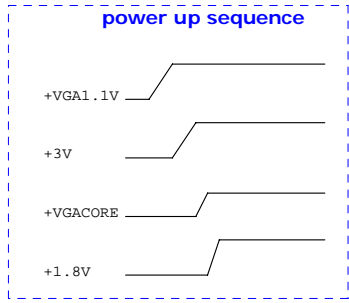
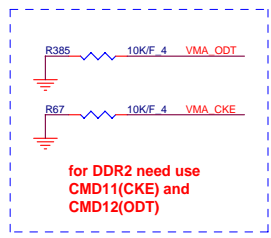
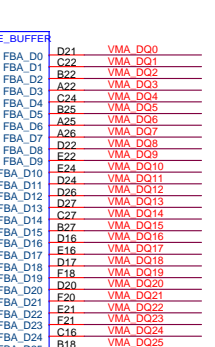
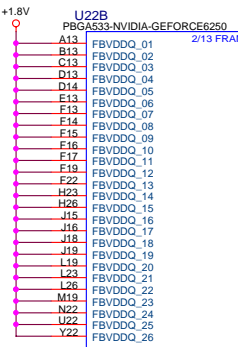

13



PROJECT : QL6  
Quanta Computer Inc.

Size Custom	Document Number NV9X (MEMORY I/F) 2/5	Rev 2A
Date: Tuesday, February 26, 2008 Sheet 13 of 40		

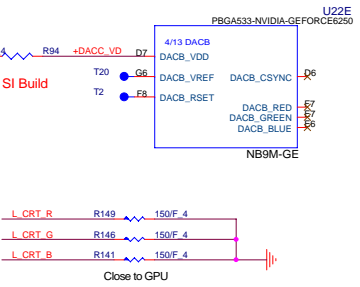
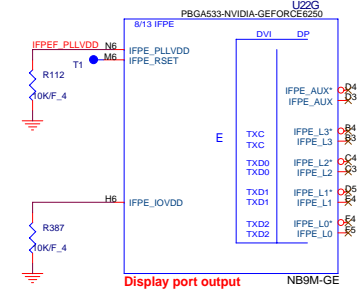
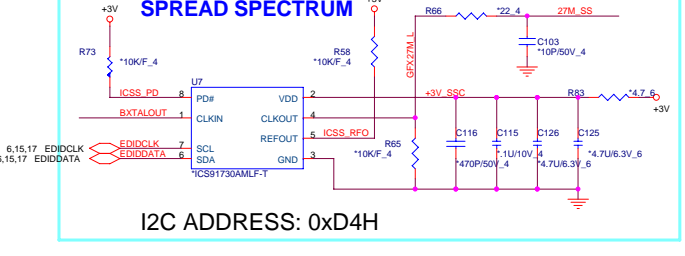
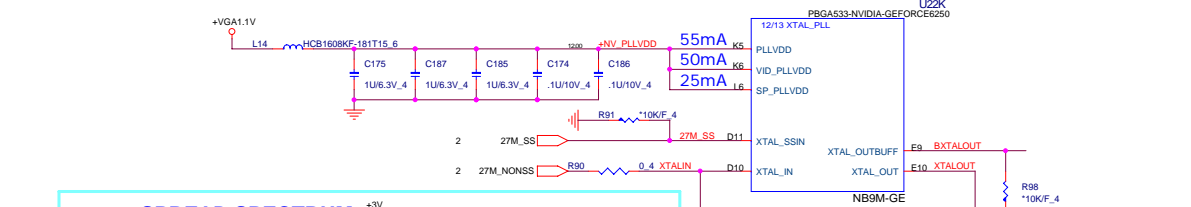
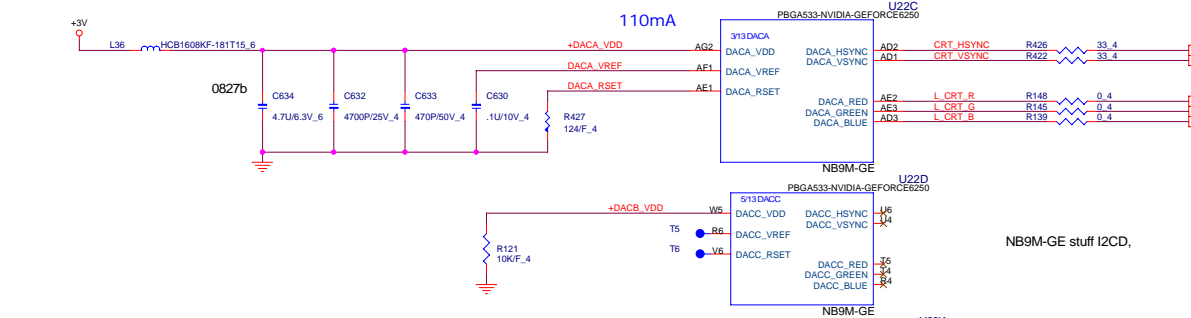
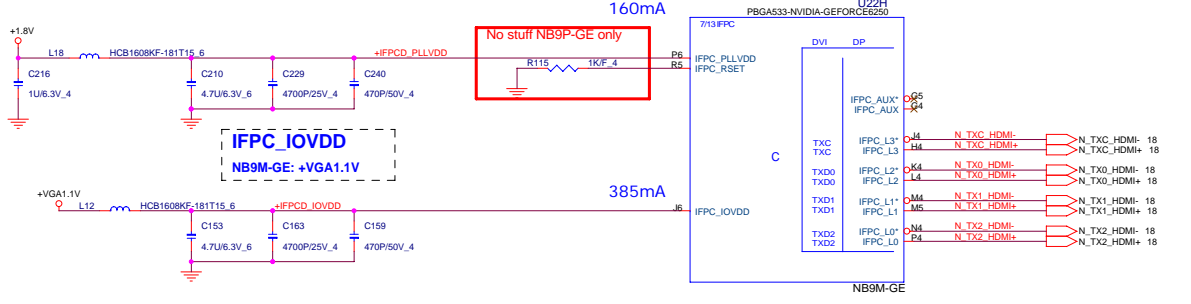
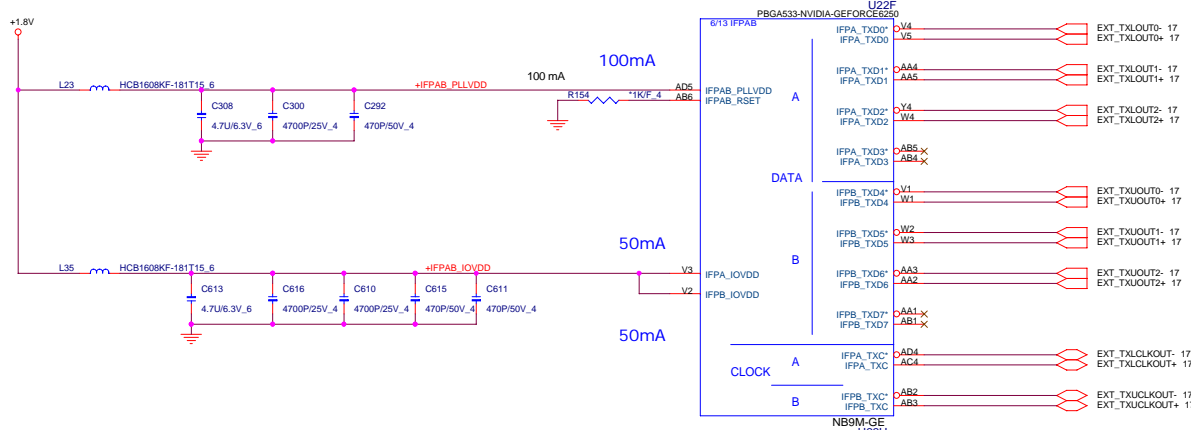

NB9M-GE stuff I2CD,

STUFF PDs on XTALSSIN and XTALOUTBUFF WHEN EXT\_SS IS NOT USED

Install it when not connected to Spread spectrum device

**PROJECT : QL6**  
Quanta Computer Inc.

Size Custom	Document Number NV9X (DISPLAY) 3/5	Rev 2A
Date: Tuesday, February 26, 2008	Sheet 14	of 40

NB5

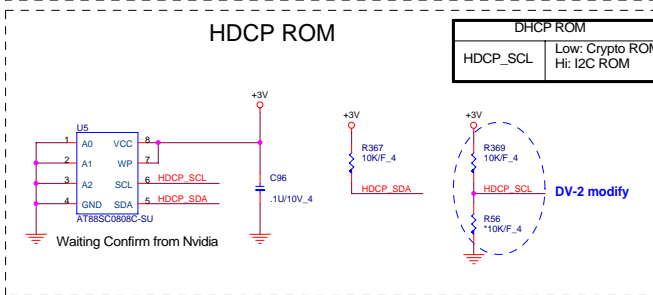
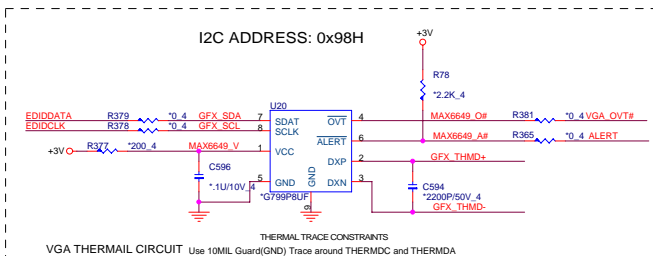
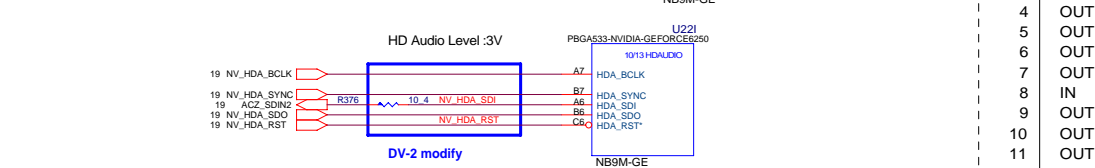
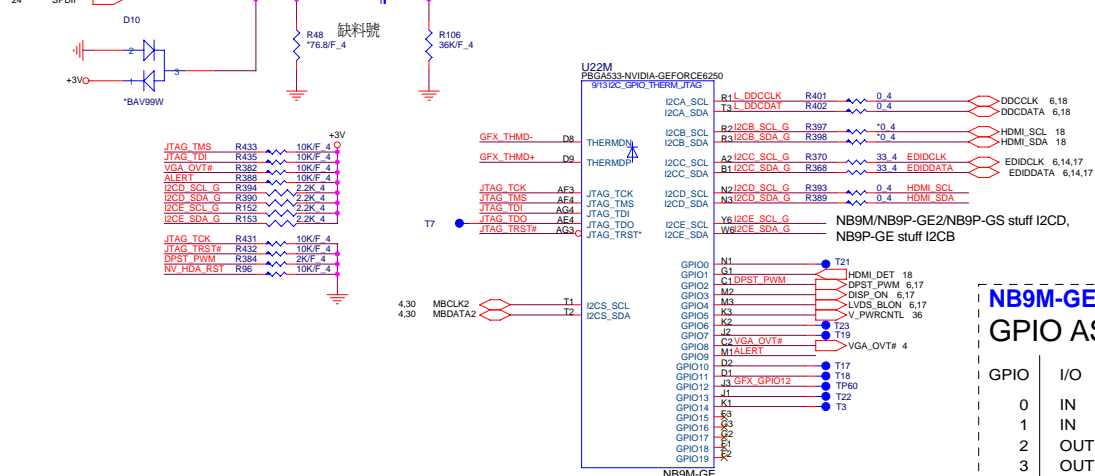
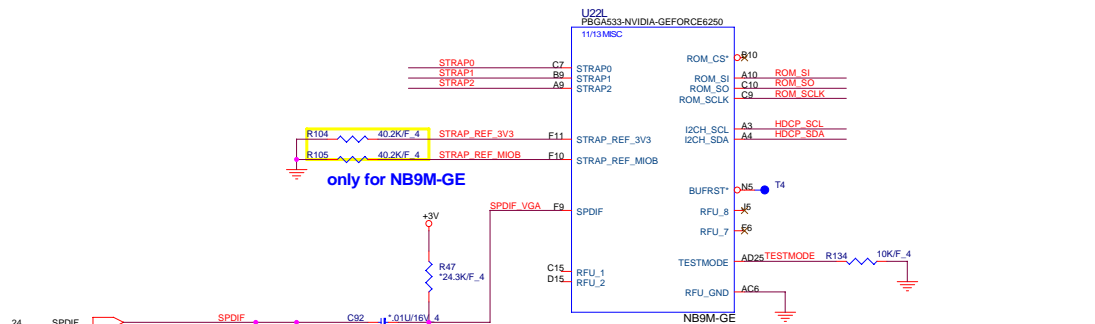

**NB9M-GE (G98) Strapps GPIO ASSIGNMENTS**

GPIO	I/O	ACTIVE	USAGE
0	IN	N/A	PRIMARY DVI HOTPLUG
1	IN	N/A	SECONDARY DVI HOTPLUG
2	OUT	HIGH	PANEL BACKLIGHT PWM
3	OUT	HIGH	PANEL POWER ENABLE
4	OUT	HIGH	PANEL BACKLIGHT ENABLE
5	OUT	N/A	NV_VDD VID0
6	OUT	N/A	NV_VDD VID1
7	OUT	N/A	FB_VDD VID0
8	IN	LOW	THERMAL ALERT
9	OUT	LOW	FAN PWM
10	OUT	N/A	FBVREF SELECT
11	OUT	N/A	SLI SYNC0
12	IN	N/A	AC DETECT
13	OUT	LOW	PS CONTROL OR HDMI_CEC
14	OUT	HIGH	PS CONTROL

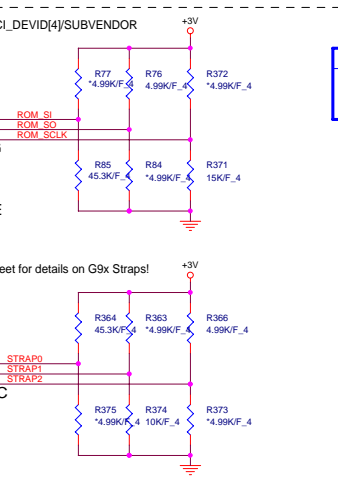

VRAM ID	
ROM_SI	PD 30K: Samsung
	PD 35K: Qimonda
	PD 45K: Hynix

**Logical Strap Bit Mapping**

PU-VDD	PD
5K	1000 0000
10K	1001 0001
15K	1010 0010
20K	1011 0011
25K	1100 0100
30K	1101 0101
35K	1110 0110
45K	1111 0111

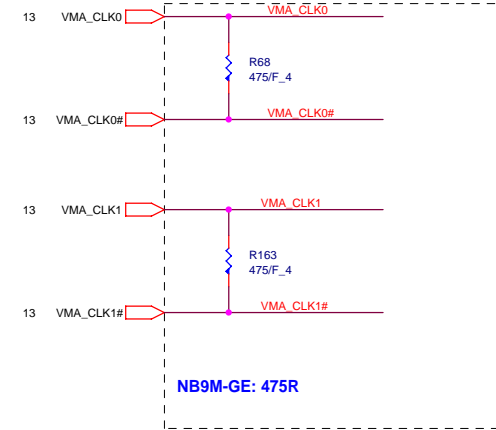
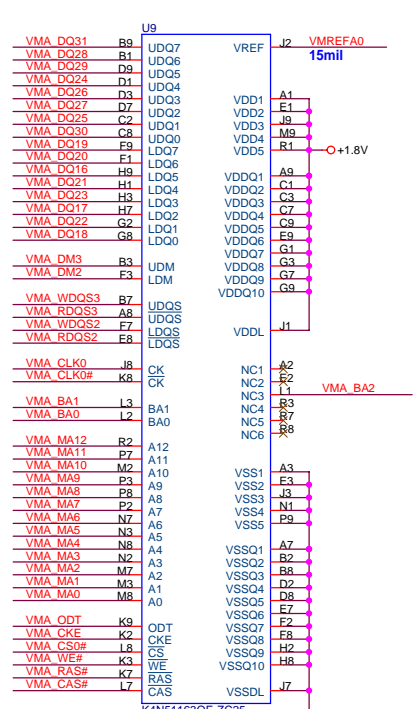
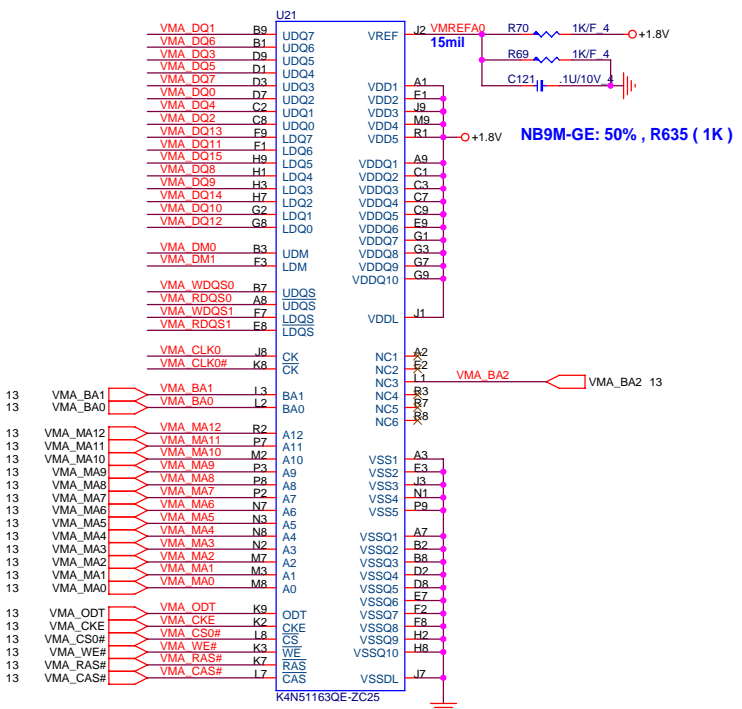

CS14752FB11 RES CHIP 475 1/16W +/-1%(0402)

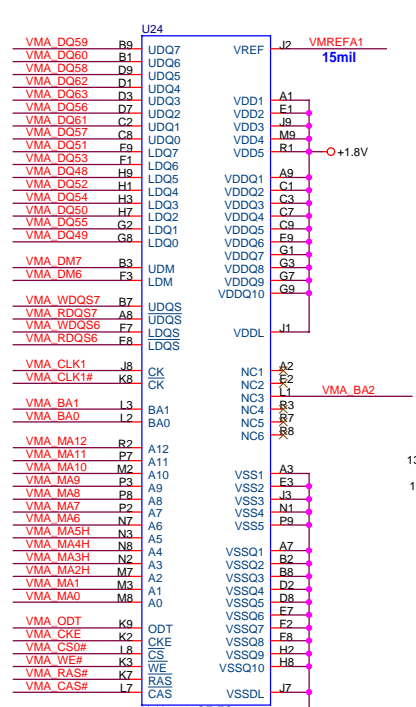
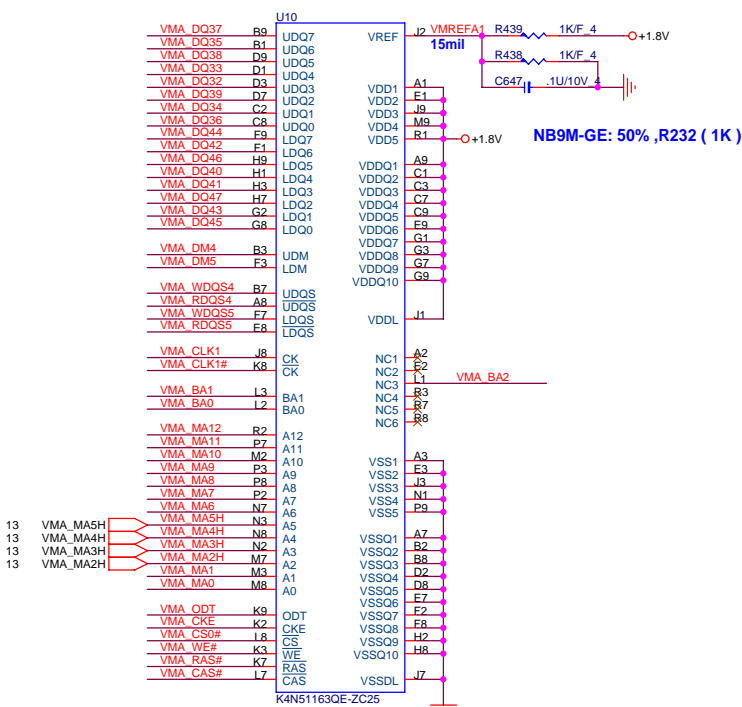
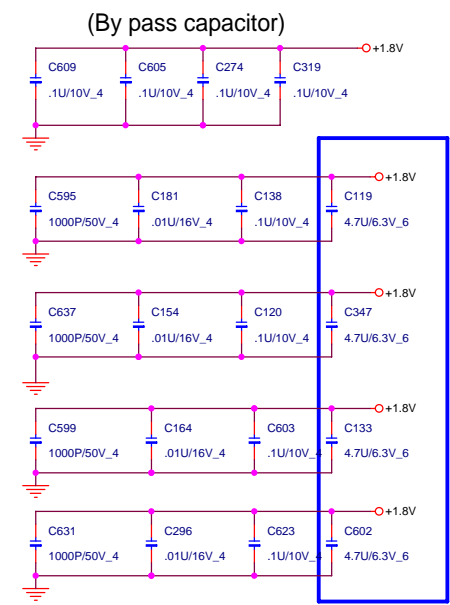

- 13 VMA\_DQ[63..0]
  - 13 VMA\_DM[7..0]
  - 13 VMA\_WDQS[7..0]
  - 13 VMA\_RDQS[7..0]
- NB9M : AKD5FG-TW31(Hynix,32M\*16)  
 AKD5FG-T\*03(Qimonda 32M\*16)  
 256Mb : AKD5JGAT\*05  
 512Mb : AKD59G-T\*01

**PROJECT : QL6**  
 Quanta Computer Inc.

NB5

Size Custom | Document Number **NV9X VRAM-1(GDDR2) 5/5** | Rev 2A  
 Date: Tuesday, February 26, 2008 | Sheet 16 of 40



1. If LCD connector near GPU, then place these series Resistors near GPU
2. If LCD connector near N/B, then place these series Resistors near N/B

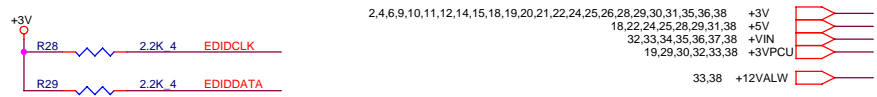
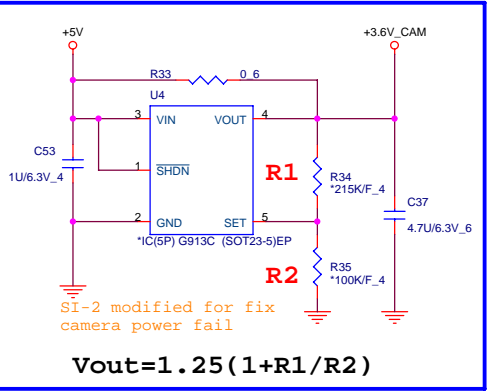
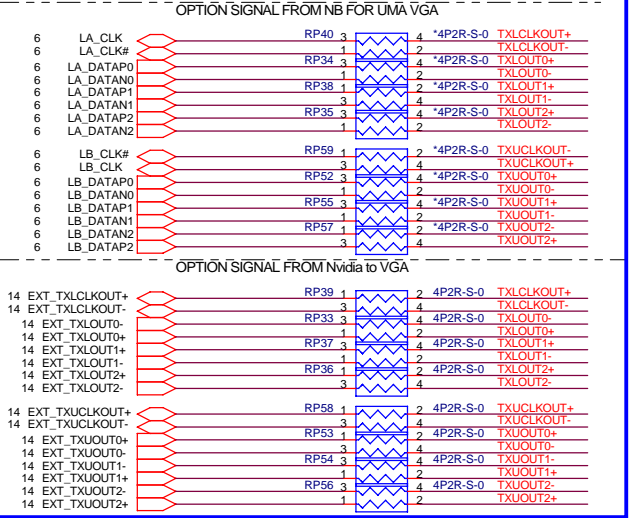

17

LCD / USB CAMERA / DIGITAL MIC CONNECTOR

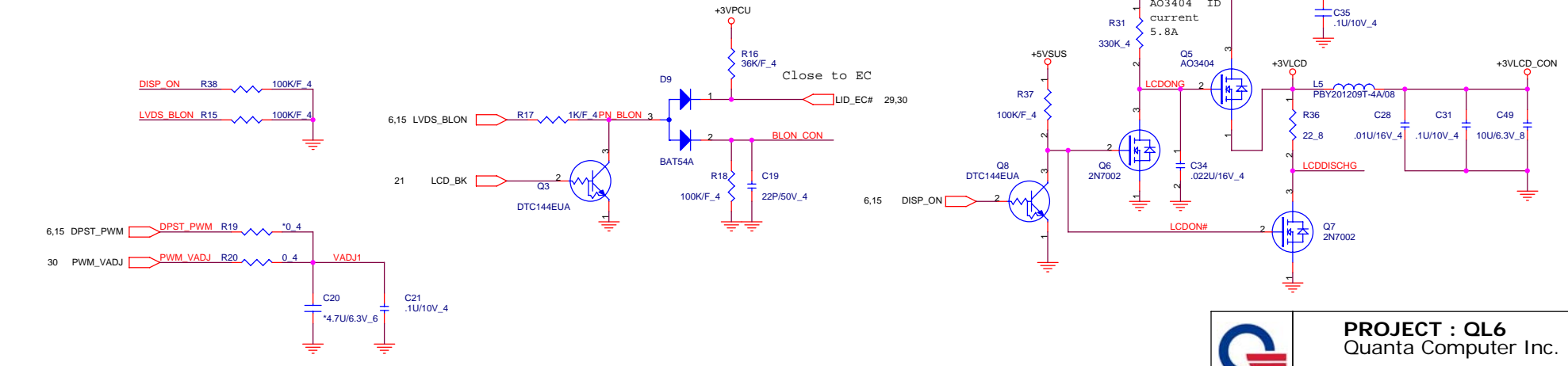
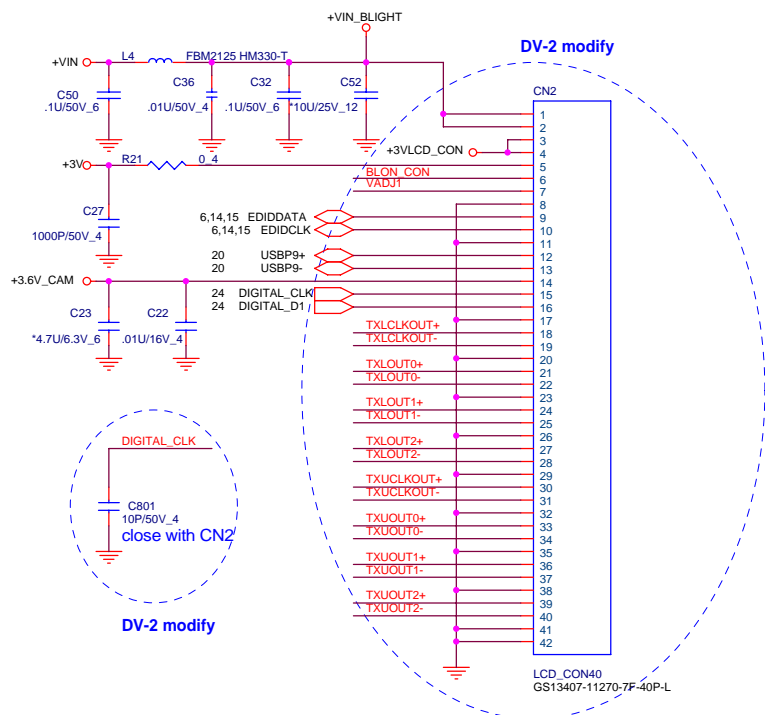

**PROJECT : QL6**  
Quanta Computer Inc.

Size Custom	Document Number <b>LCD CONN(WC/MIC)/LID</b>	Rev 2A
Date: Tuesday, February 26, 2008 Sheet 17 of 40		

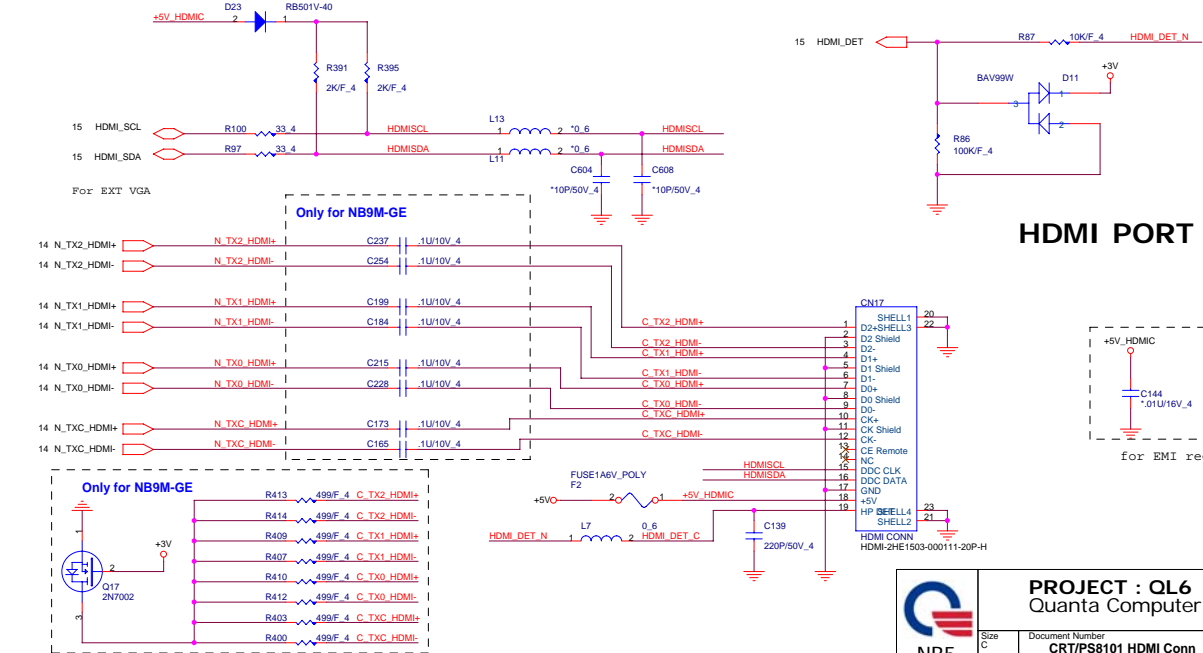
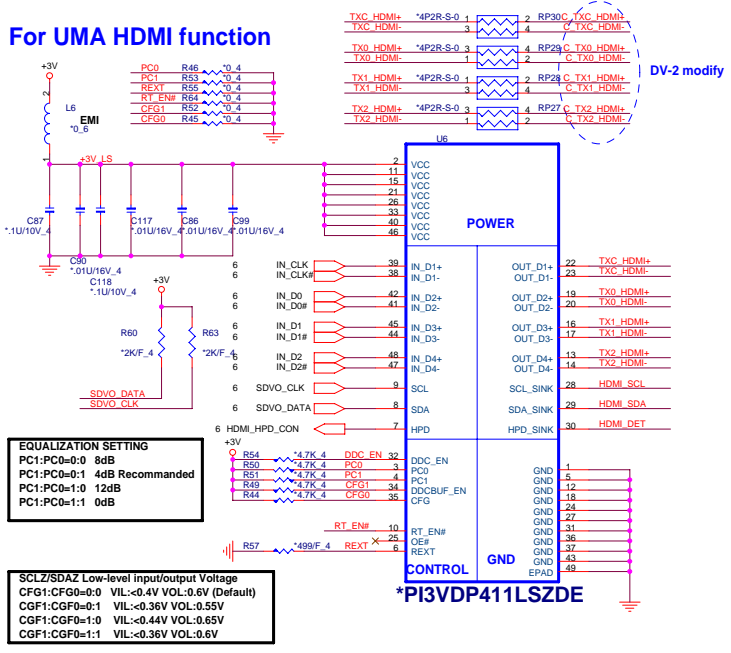
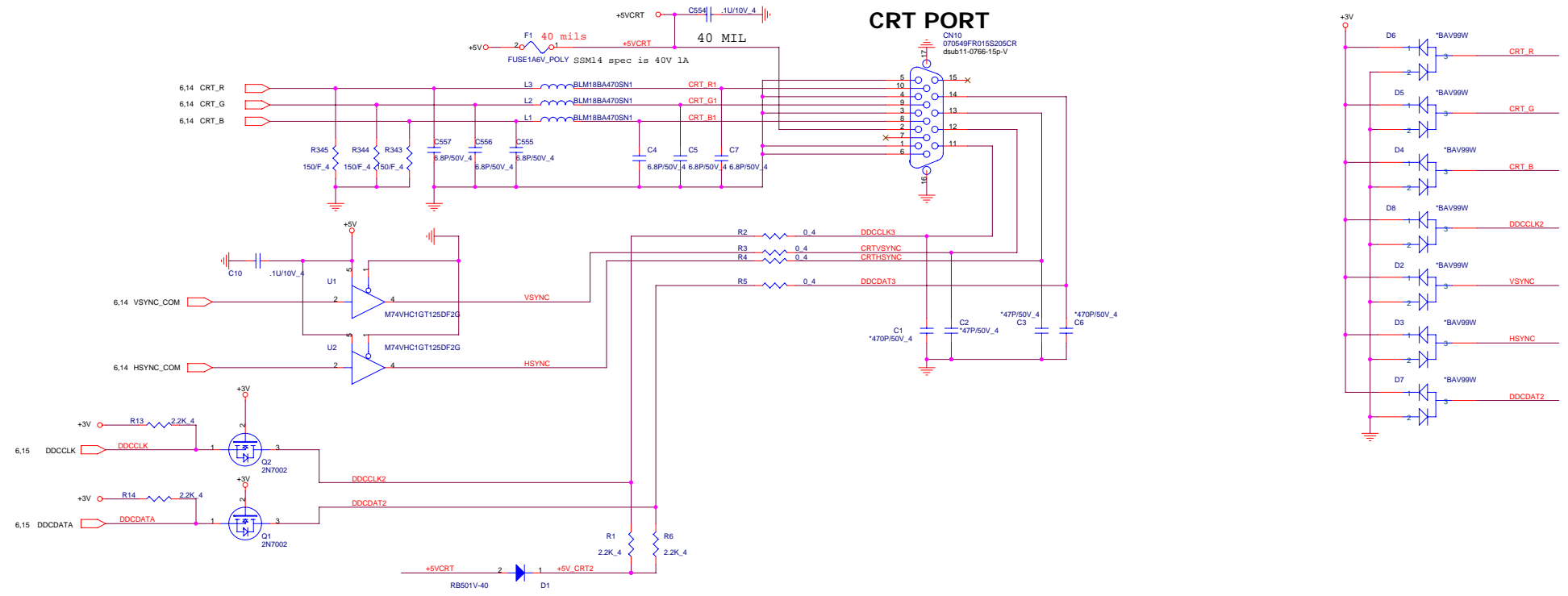

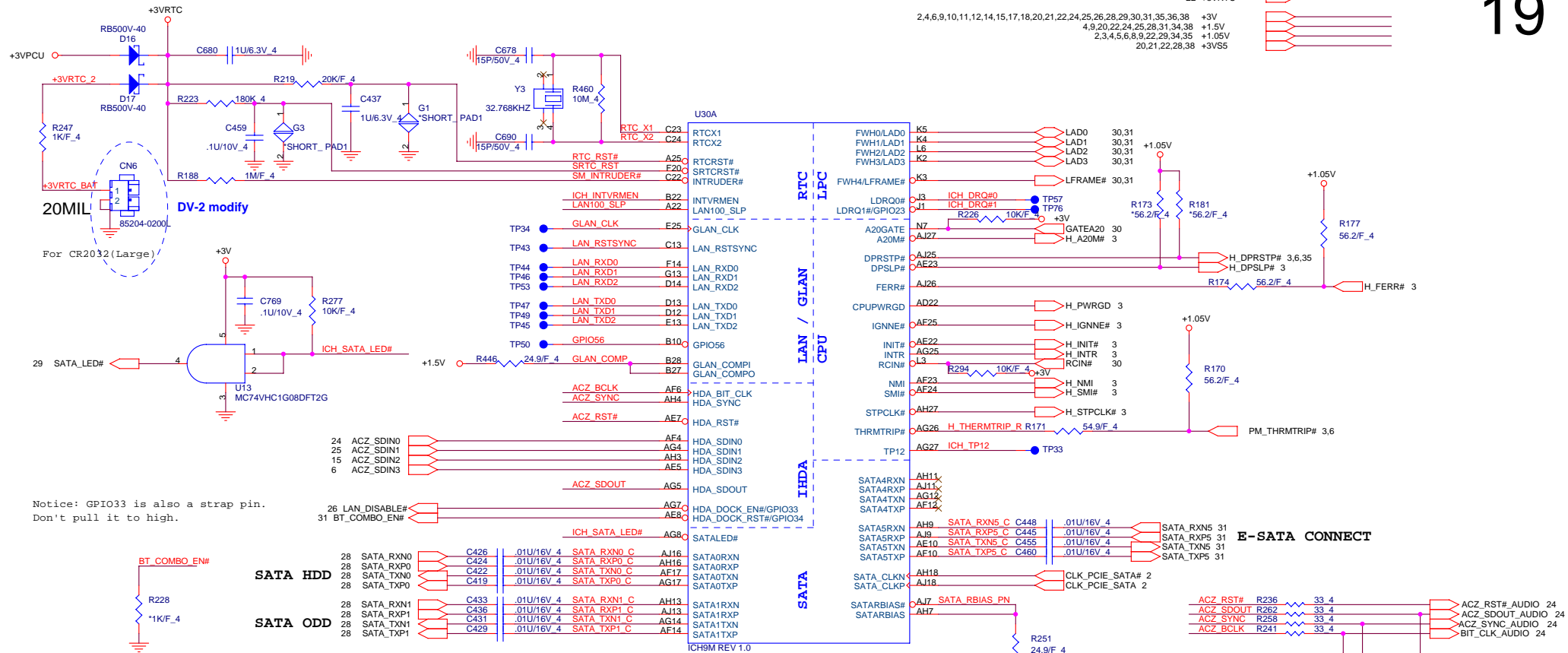

## SB Strap

**ICH9-M Internal VR Enable strap**  
(Internal VR for Vccsus1\_05, Vccsus1\_5 and VccCL1\_5)

**ICH9-M LAN100\_SLP Strap**  
(Internal VR for VccLAN1\_05 and VccCL1\_05)

INTVRMEN	Low = Internal VR disable High = Internal VR enable(Default)	LAN100_SLP	Low = Internal VR disable High = Internal VR enable(Default)
----------	---	------------	---

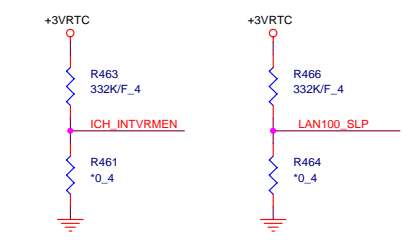

## XOR Chain Entrance Strap

ICH_TP3	HDA_SDOUT	Description
0	0	RSVD
0	1	Enter XOR Chain
1	0	Normal operation(Default)
1	1	Set PCIe port config bit 1

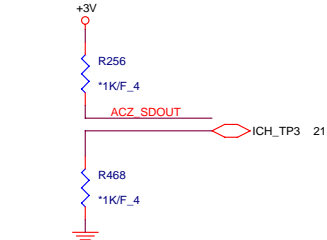

## ICH9 Boot BIOS select

STRAP	PCI_GNT0#	SPL_CS#1
SPI	0	1
PCI	1	0
LPC	1	1

(default)



## A16 swap override strap

PCI_GNT#3	Low = A16 swap override enabled Hi = Default
-----------	---



ACZ_SPKR	Low: Default Hi: No reboot
----------	-------------------------------

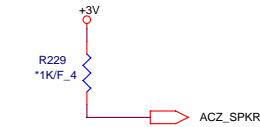

ICH_GPIO57	Low: Default
------------	--------------

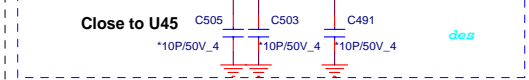
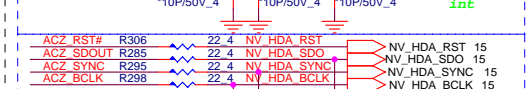
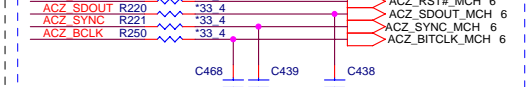
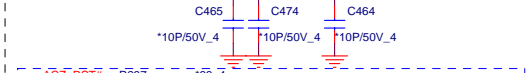
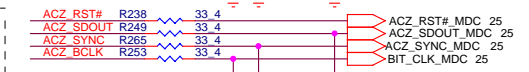
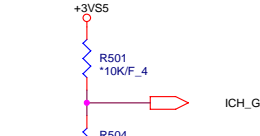

**PROJECT : QL6**  
Quanta Computer Inc.

Size Custom	Document Number <b>ICH9-M Host 1/4</b>	Rev 2A
Date: Tuesday, February 26, 2008 Sheet 19 of 40		



MINI CARD PCI-E(WLAN)

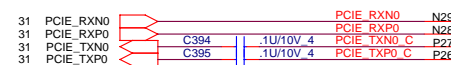

EXPRESS CARD (NEW CARD)

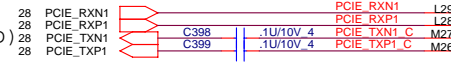

MINI CARD PCI-E(Robson)

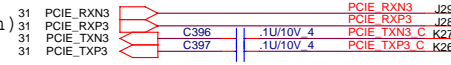

PCI-E-LAN

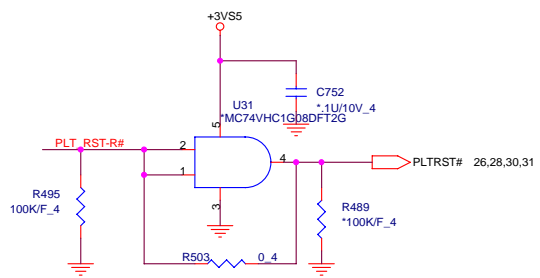
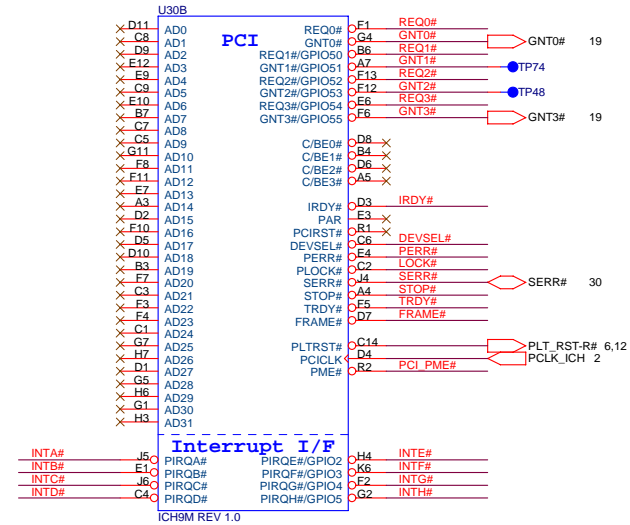
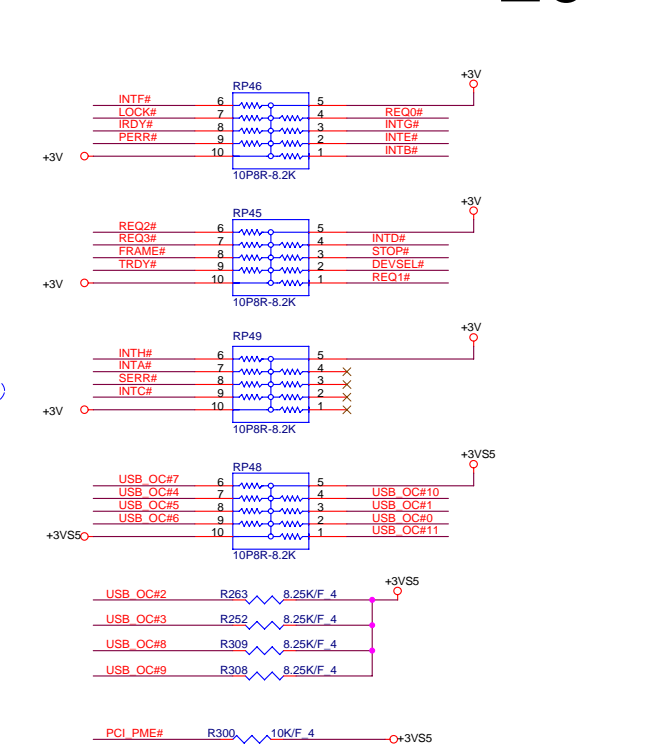
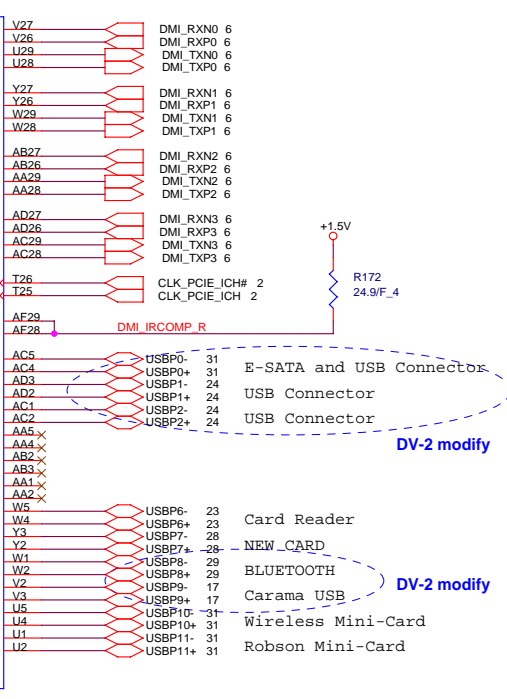
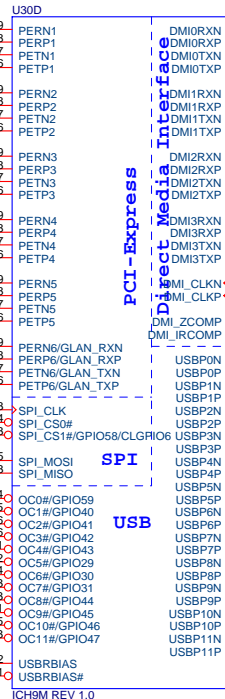
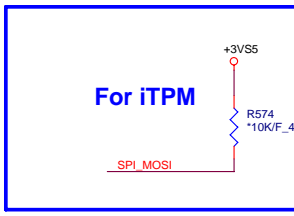
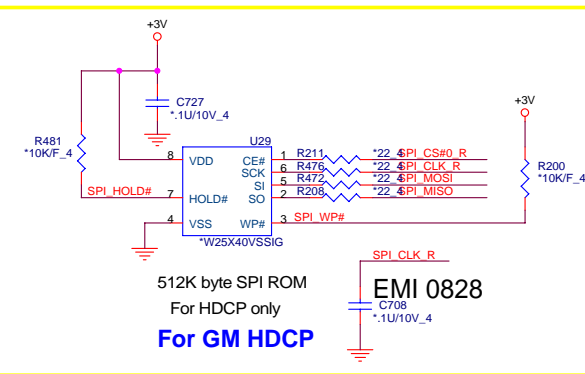
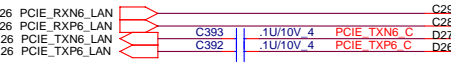

4,9,19,20,22,24,25,28,31,34,38 +1.5V  
 2,4,6,9,10,11,12,14,15,17,18,19,20,22,24,25,26,28,29,30,31,35,36,38 +3V  
 19,20,22,28,38 +3VS5  
 23,29,31,34,35,36,38 +3VSUS

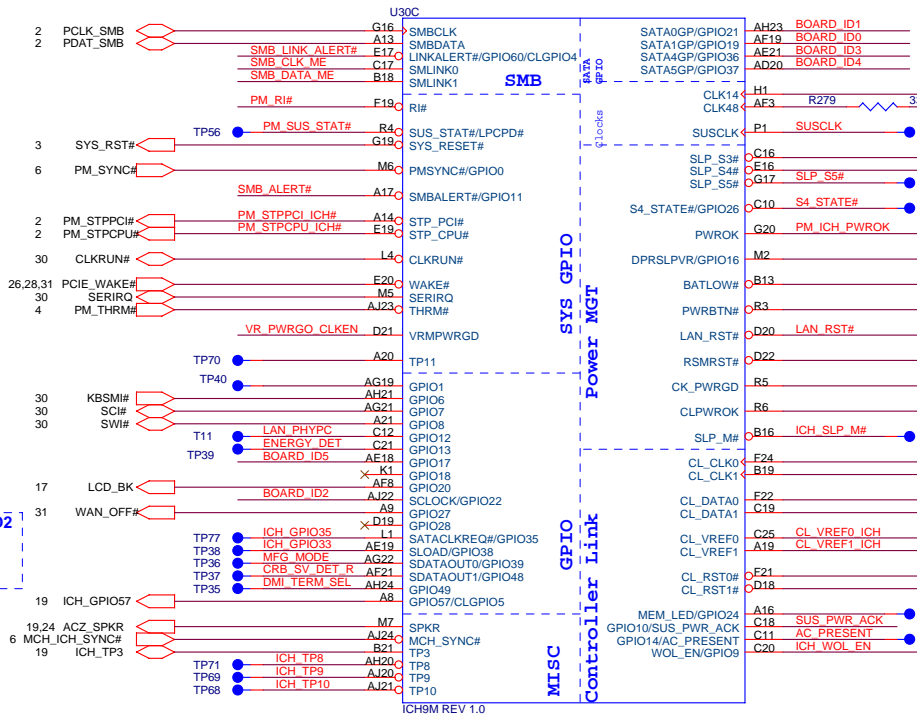

**BIOS\_REC:BOARD\_ID2**  
 Default is PH  
 For Bios recovery PD

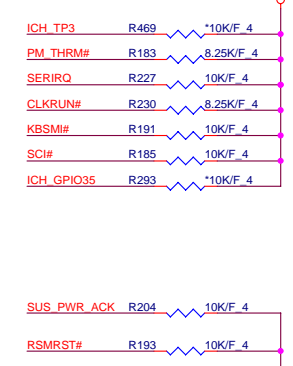
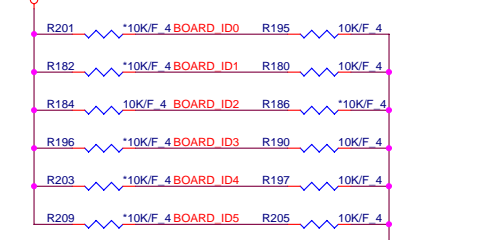
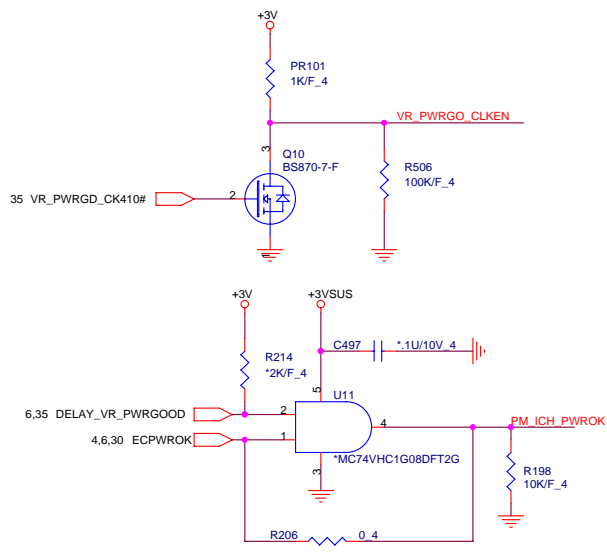
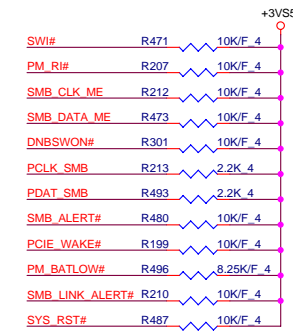
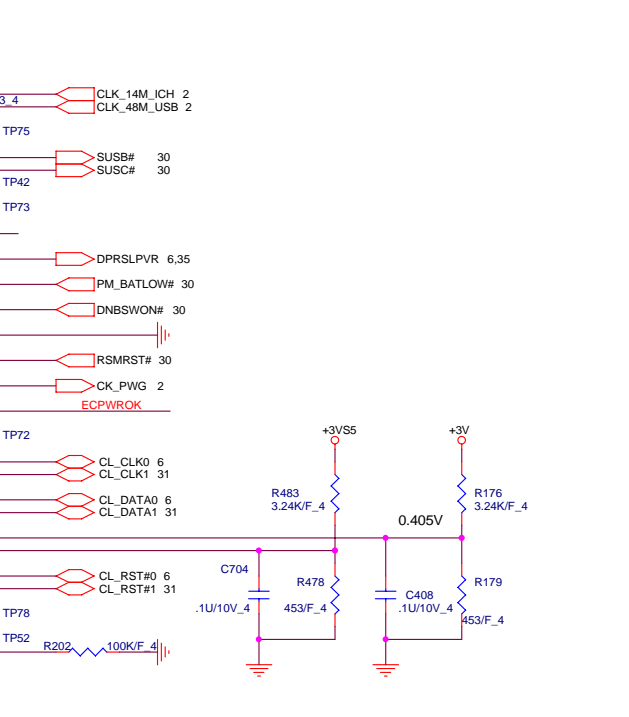

Board ID 4/5 pull low

Model	Board ID 3	Board ID 2	Board ID 1	Board ID 0
QL8/GM	0	0	0	0
QL8/9M	0	0	0	1
QL8/9P	0	0	1	0
QL6/GM	0	0	1	1
QL6/9M	0	1	0	0
TW8/GM	0	1	0	1
TW8/9M	0	1	1	0
TW8/9P	0	1	1	1
SW8/GM	1	0	0	0
SW8/9M	1	0	0	1
DW8/GM	1	0	1	0

**PROJECT : QL6**  
 Quanta Computer Inc.

Size Custom	Document Number	Rev 2A
NB5		2A
Date: Tuesday, February 26, 2008	Sheet 21 of 40	

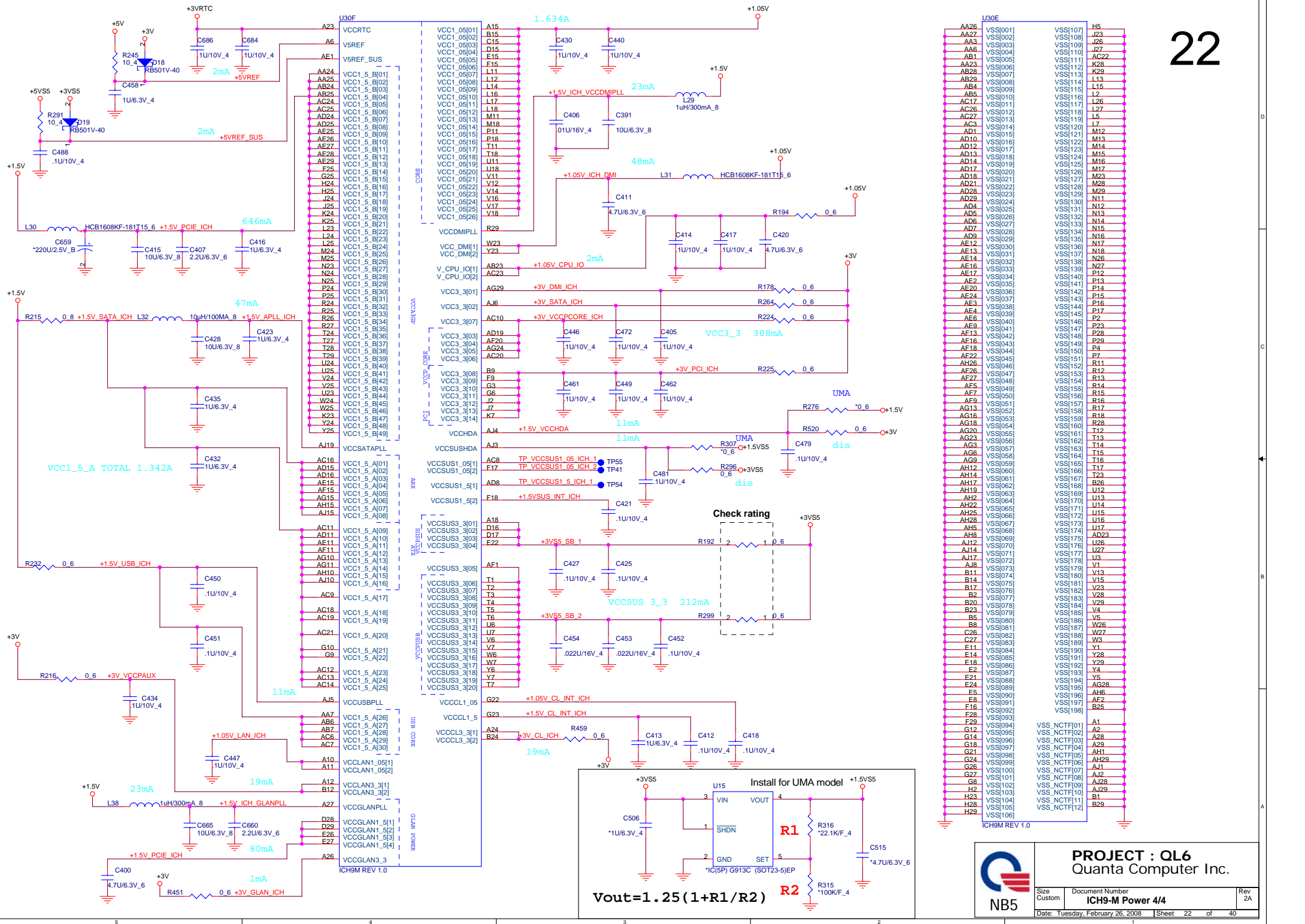

	<b>PROJECT : QL6</b>	
	Quanta Computer Inc.	
Size Custom	Document Number ICH9-M Power 4/4	Rev 2A
Date: Tuesday, February 26, 2008   Sheet 22 of 40		

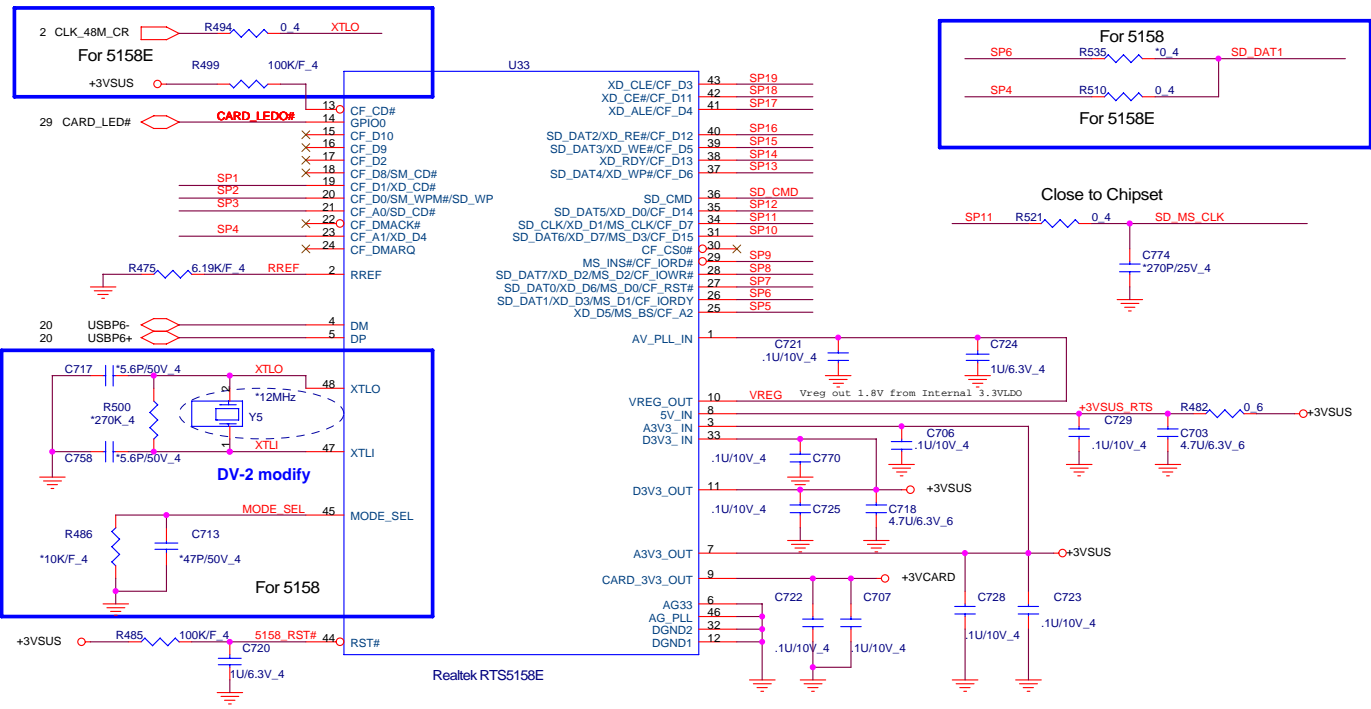

**Note:**

SD/MMC	MS	XD
SP0		XD CD#
SP1	SD_WP	XD CD#
SP2	SD_CD#	
SP3	SD_CD#	
SP4	SD_DAT1	XD D4
SP5	MS_BS	XD D5
SP6	SD_DAT1	MS D1
SP7	SD_DAT0	MS D0
SP8	SD_DAT7	MS D2
SP9	MS_INS#	
SP10	SD_DAT6	MS D3
SP11	SD_CLK	MS SCLK
SP12	SD_DAT5	XD D0
SP13	SD_DAT4	XD_WP#
SP14		XD R/#
SP15	SD_DAT3	XD_WE#
SP16	SD_DAT2	XD_RE#
SP17		XD_ALE
SP18		XD_CE#
SP19		XD_CLE

**5 IN1 CARD READER**  
**XD, MMC/SD, MS/MSP**

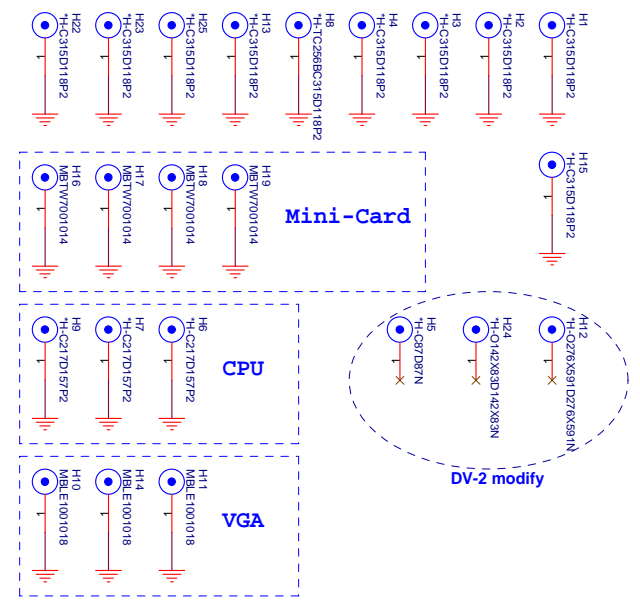
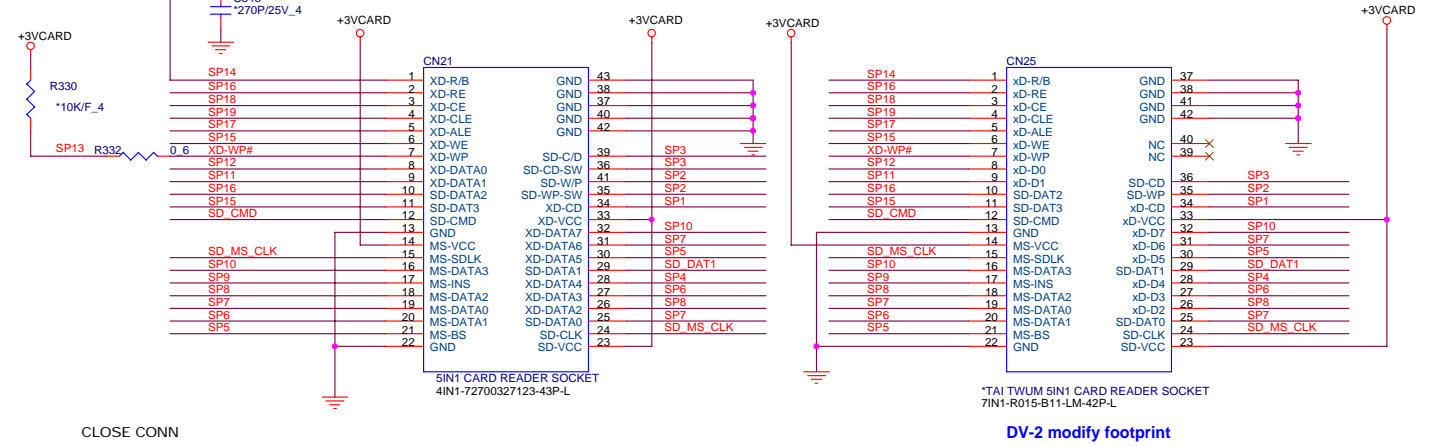

**PROJECT : QL6**  
**Quanta Computer Inc.**

**NB5**

Size Custom	Document Number	Rev 2A
	<b>RTSS158 &amp; CR SOCKET &amp; HOLE</b>	
Date: Tuesday, February 26, 2008	Sheet 23 of 40	

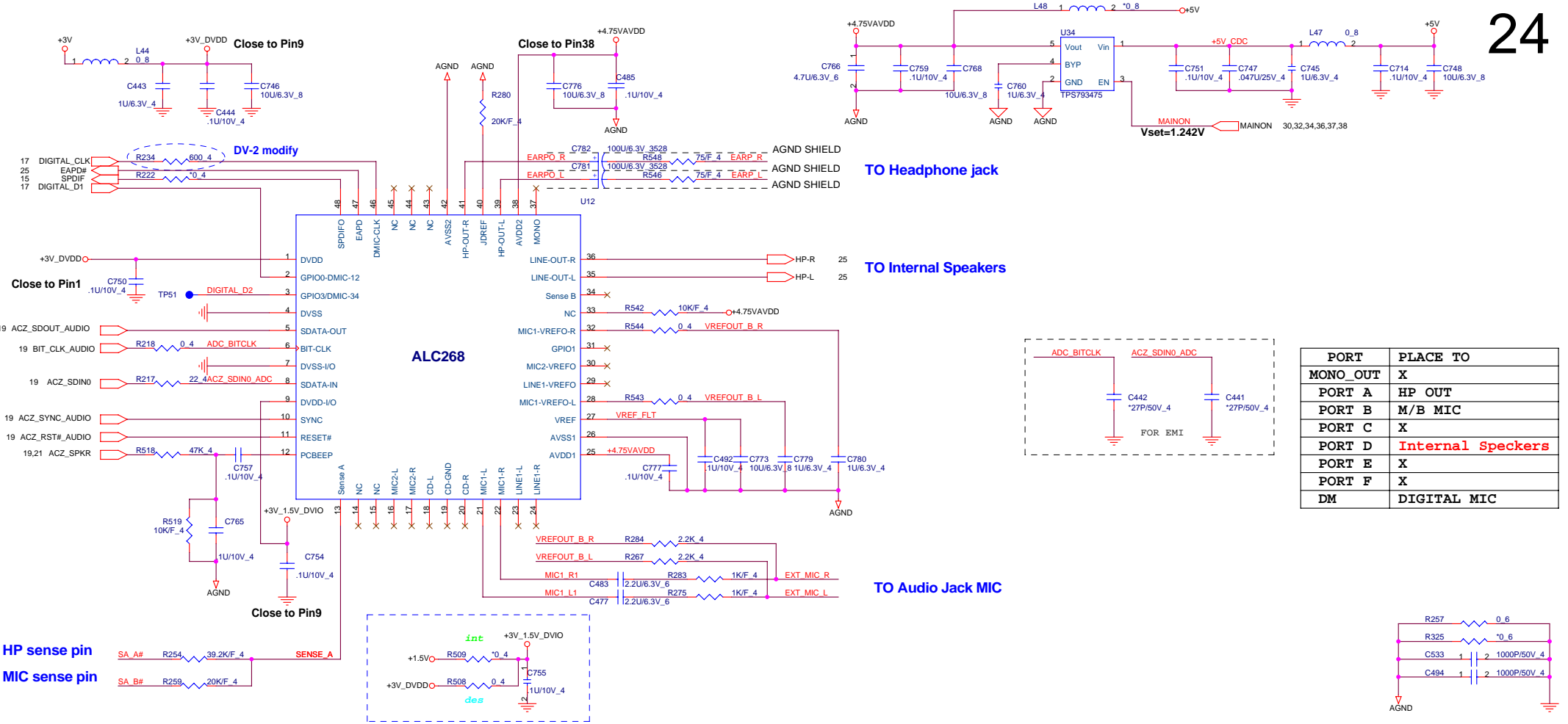

TO Headphone jack

TO Internal Speakers

TO Audio Jack MIC

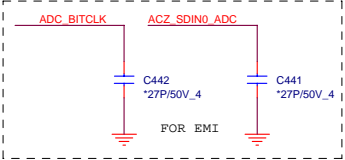

PORT	PLACE TO
MONO_OUT	X
PORT A	HP OUT
PORT B	M/B MIC
PORT C	X
PORT D	Internal Speakers
PORT E	X
PORT F	X
DM	DIGITAL MIC

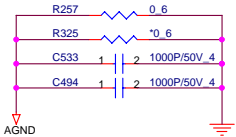

AUDIO/USB BOARD CONNECTOR

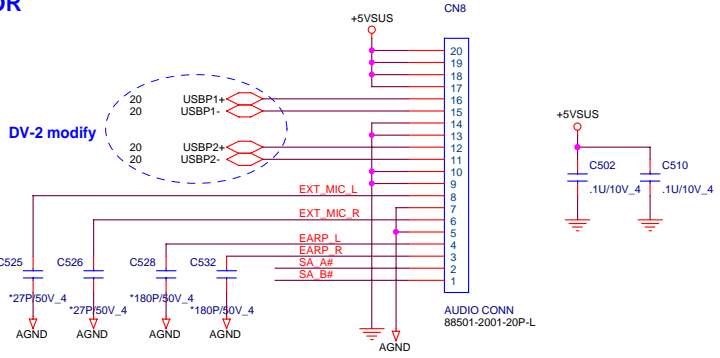

	<b>PROJECT : QL6</b>		Rev 2A
	Quanta Computer Inc.		
	Size Custom	Document Number <b>Azalia IDT92HD71B7</b>	
Date: Tuesday, February 26, 2008		Sheet 24 of 40	



# AUDIO AMPLIFIER

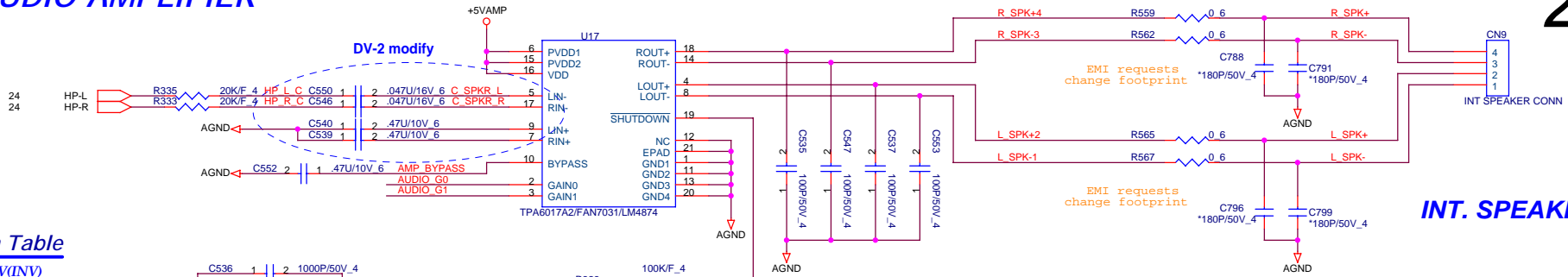

## 6017A2 Gain Table

GAIN0 GAIN1 AV(INV)

0	0	6dB
0	1	10dB
1	0	15.6dB
1	1	21.6dB

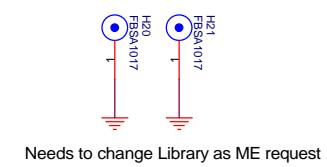
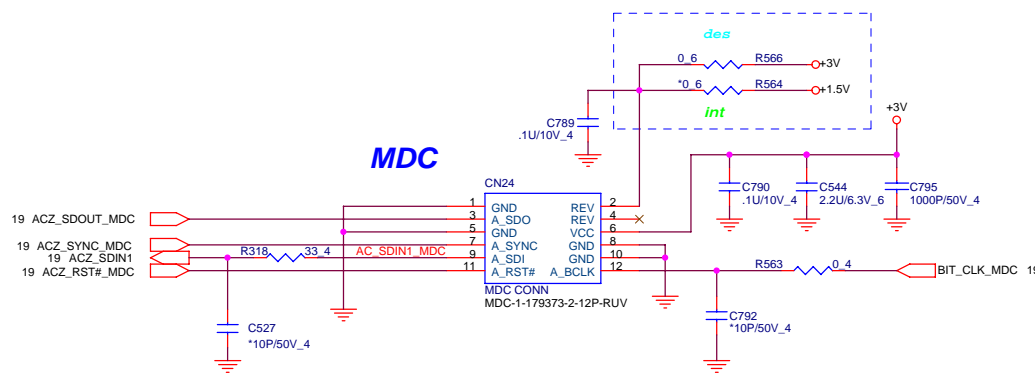
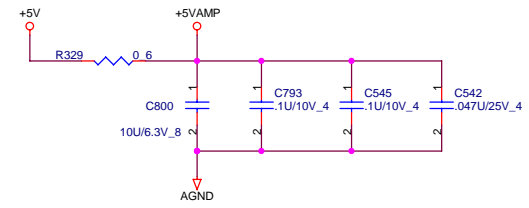
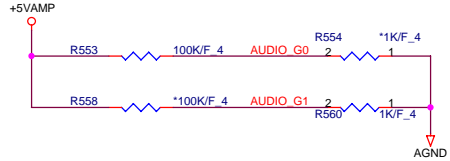
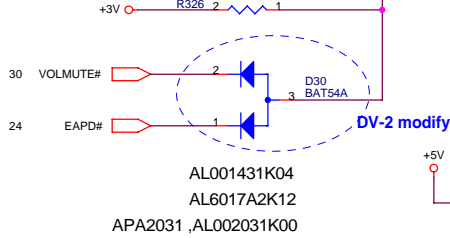
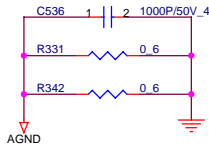

**PROJECT : QL6**  
Quanta Computer Inc.

Size Custom	Document Number <b>AMP_TPA6017/MDC</b>	Rev 2A
Date: Tuesday, February 26, 2008   Sheet 25 of 40		

T : Stuffed for RTL8111C(10/100/1000)

E : Stuffed for 8102E(10/100)

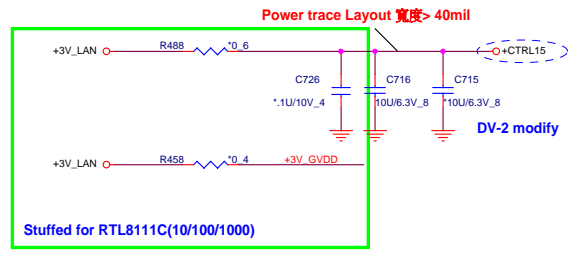
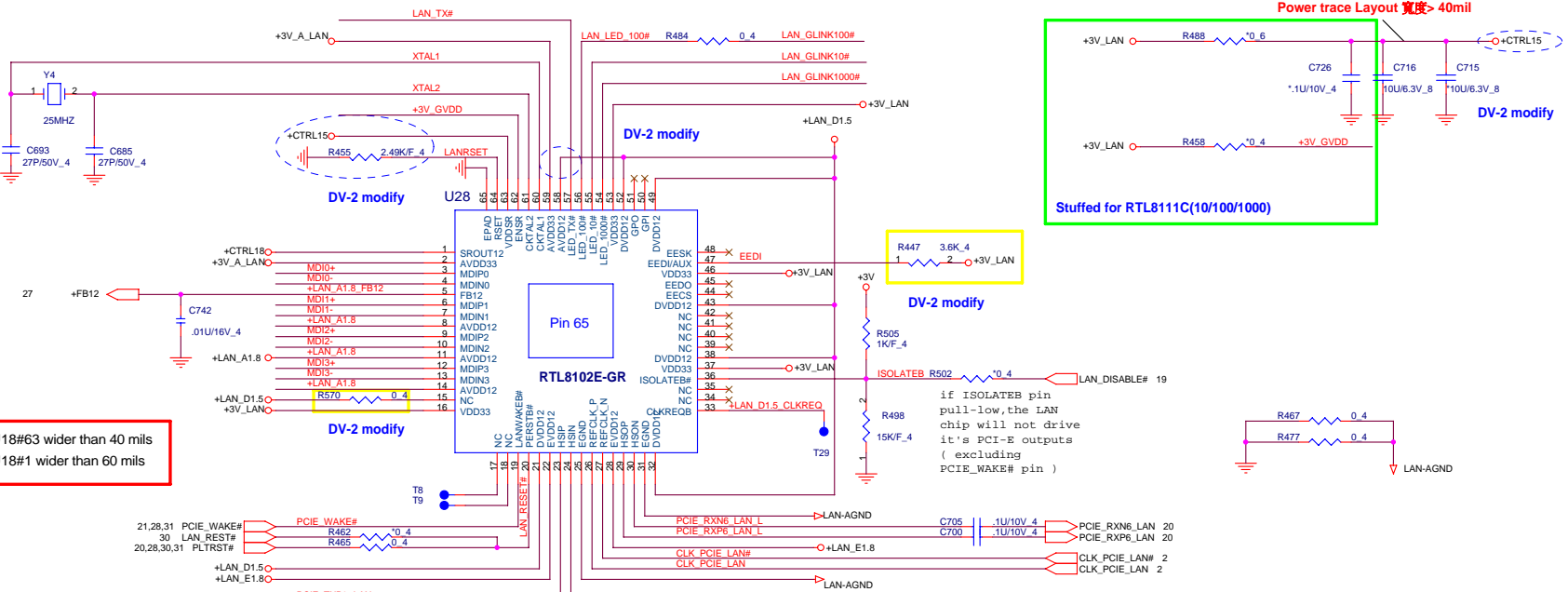
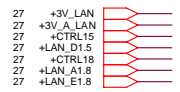

U18#63 wider than 40 mils  
U18#1 wider than 60 mils

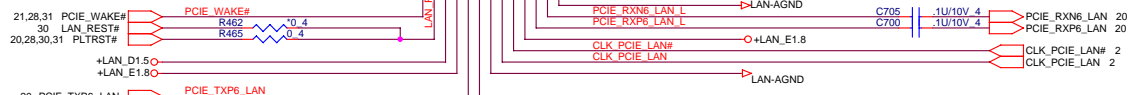
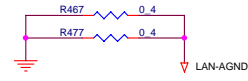
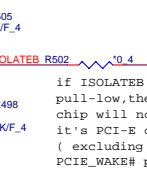
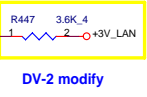

AL08111C001 IC CTRL(64P) RTL8111C-VB-GR(QFN)  
AL08102E001 IC CTRL(64P) RTL8102E-GR(QFN)

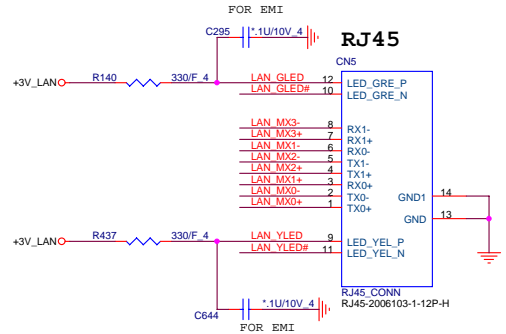
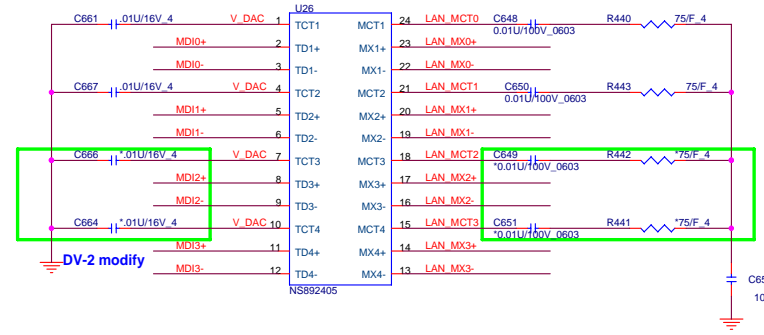
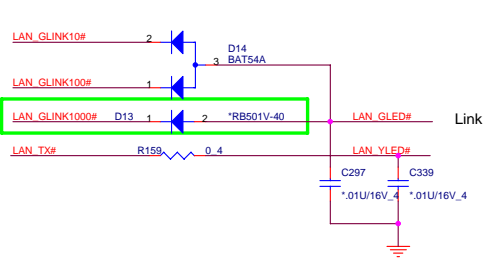

NS892402:GIGABIT DB0AT9LAN05  
NS892405:10/100 DB0ZB1LAN04

PROJECT : QL6  
Quanta Computer Inc.  
NB5  
Size Custom Document Number RTL8111C/8101E/RJ45 Rev 2A  
Date: Tuesday, February 26, 2008 Sheet 26 of 40

- T : Stuffed for RTL8111C(10/100/1000)
- E : Stuffed for 8102E(10/100)
- other

LANVCC  
1.2W  
364mA

Power trace Layout 寬度> 30mil

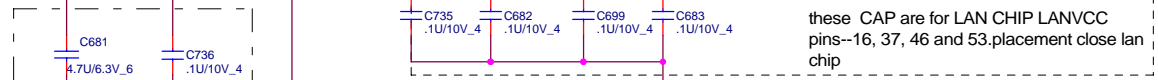

these CAP are for LAN CHIP LANVCC pins--16, 37, 46 and 53.placement close lan chip

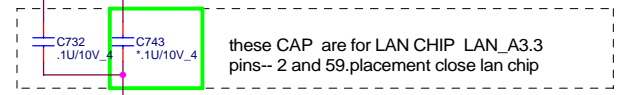

these CAP are for LAN CHIP LAN\_A3.3 pins-- 2 and 59.placement close lan chip

placement close to lan chipset

8111C CV-4706MN00  
8102E CS00004JA40  
For Giga must change L65 to Inductor (Chipset include switch power)  
+CTRL18 will become to switch power phase

L43 for Giga lan use 4.7uH power choke  
A>500mA tolerance ±15%

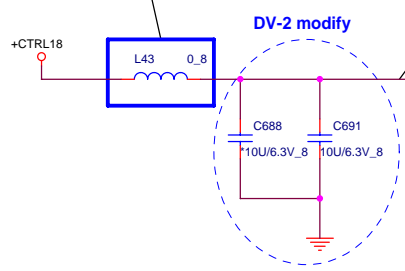

DV-2 modify

Power trace Layout 寬度> 30mil

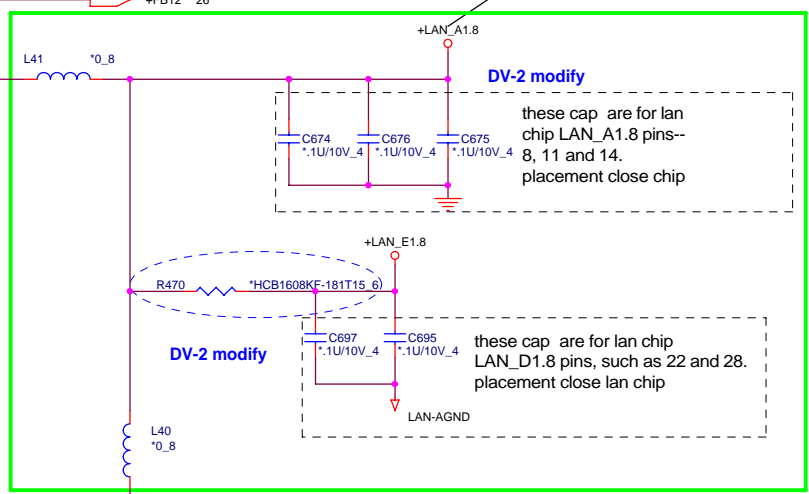

DV-2 modify

these cap are for lan chip LAN\_A1.8 pins-- 8, 11 and 14. placement close chip

DV-2 modify

these cap are for lan chip LAN\_D1.8 pins, such as 22 and 28. placement close lan chip

Power domain chart

	RTL8111C / RTL8102E
LANVCC	3.3V
LAN_D1.8	1.2V
LAN_A1.8	1.2V
LAN_D1.5	1.2V

Power trace Layout 寬度> 30mil

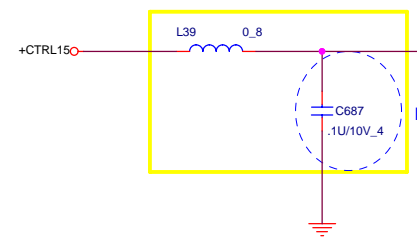

DV-2 modify

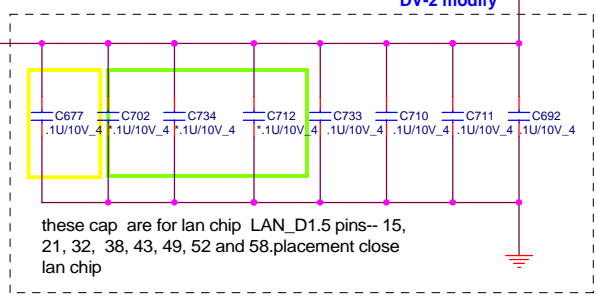

DV-2 modify

these cap are for lan chip LAN\_D1.5 pins-- 15, 21, 32, 38, 43, 49, 52 and 58.placement close lan chip



PROJECT : QL6  
Quanta Computer Inc.

Size A3	Document Number LAN Power	Rev 2A
Date: Tuesday, February 26, 2008   Sheet 27 of 40		

SATA ODD CONECTOR

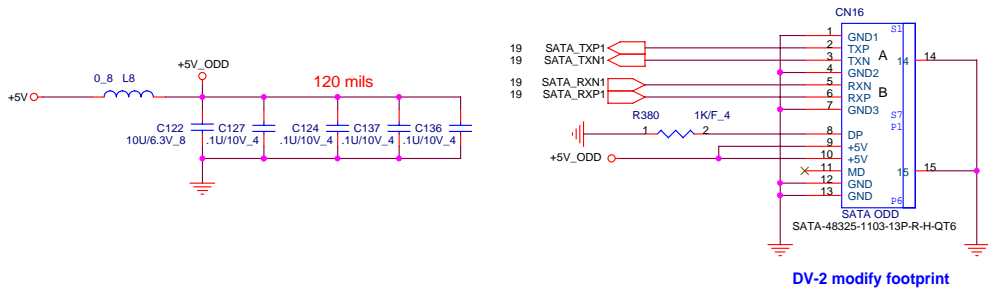

SATA HDD CONNECTOR

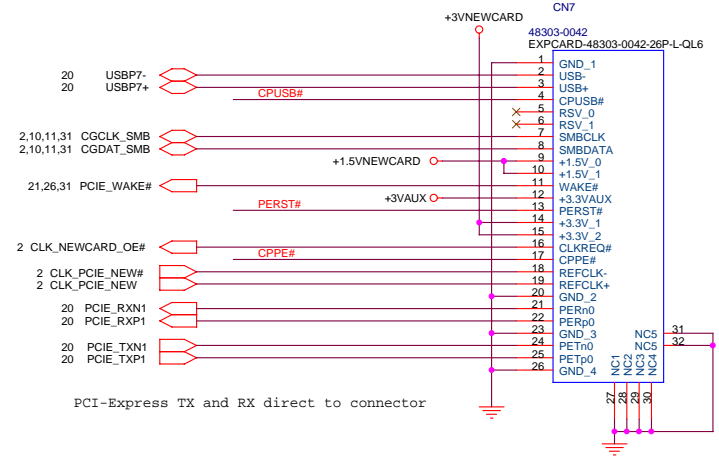
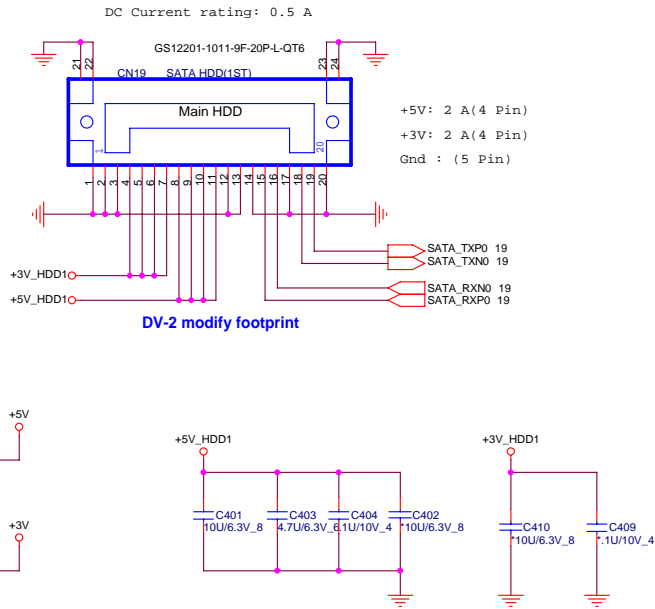

EXPCARD-48303-0042-26P-L-QT6 as ME modify Pad size(pin31,32) DV-2 modify

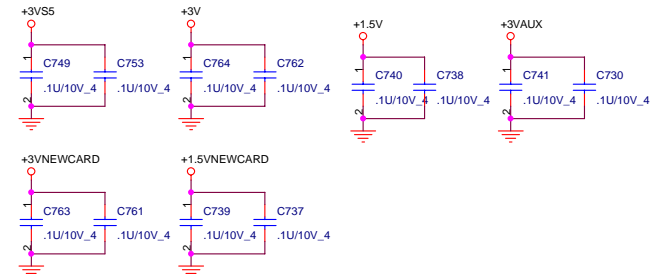
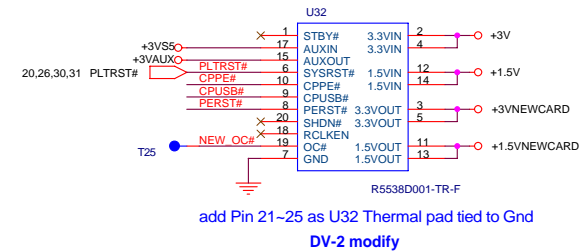

**BLUETOOTH POWER**

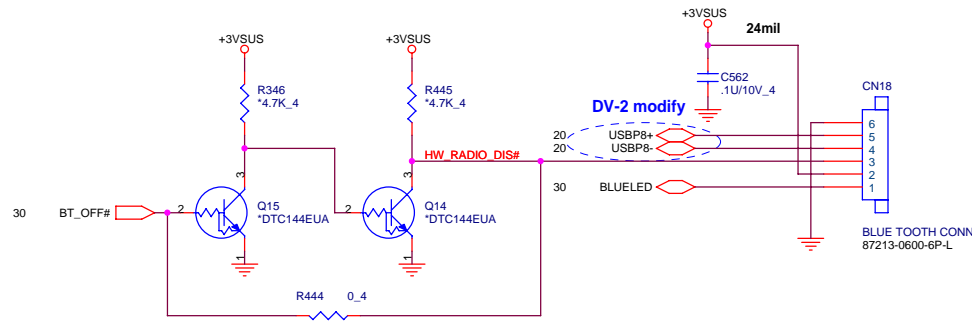

**POWER BOTTON CONNECT**

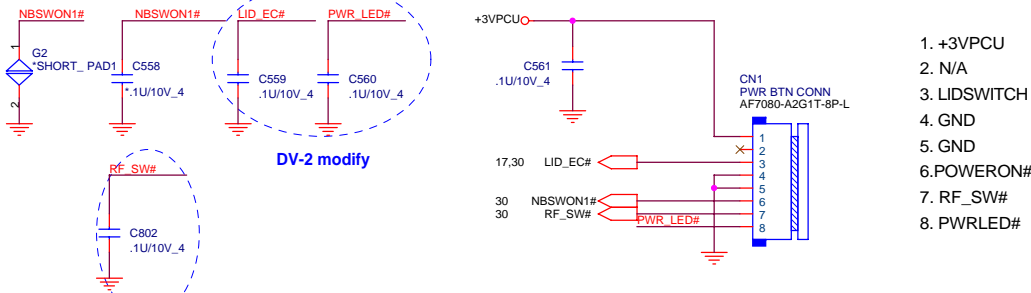

1. +3VPCU
2. N/A
3. LIDSWITCH
4. GND
5. GND
6. POWERON#
7. RF\_SW#
8. PWRLED#

**LED**

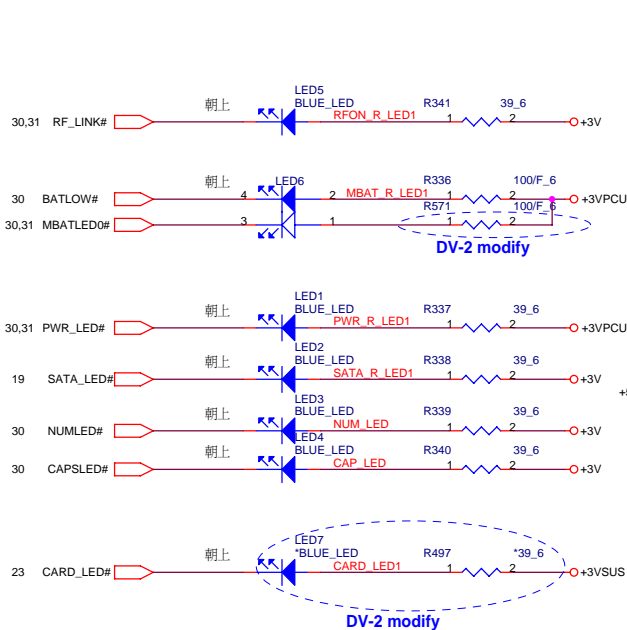

**CPU FAN**

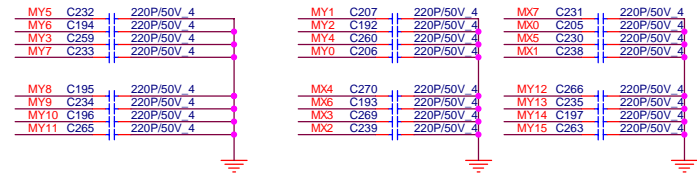
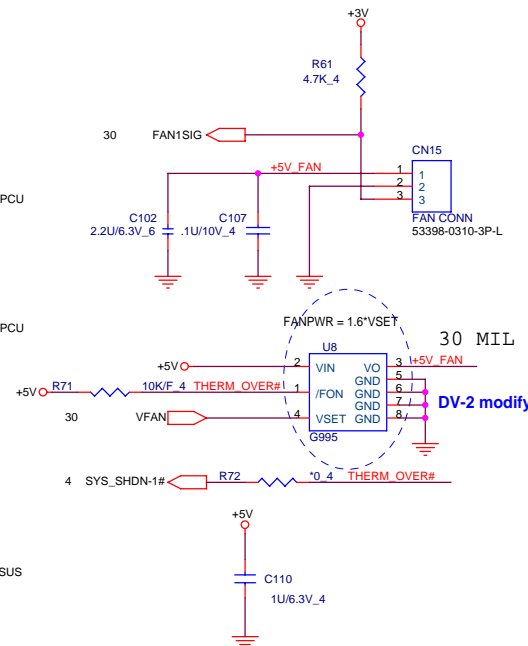

**KEYBOARD PULL-UP**

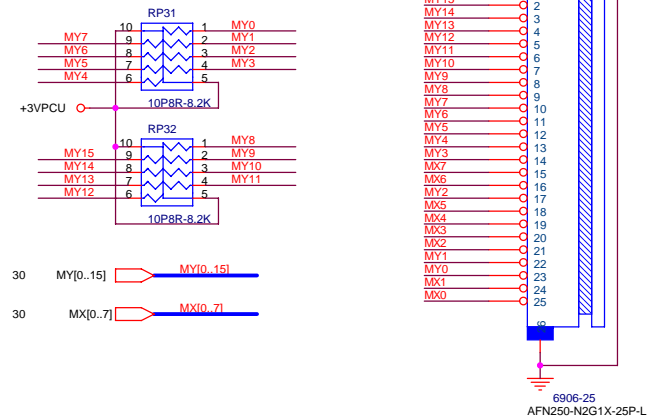

25	129	33	113	59	46	36	91	118	119	12	102	124
	App	D	F2	Fn	Z	H	num 7	F7	F8	-	num 6	F8
24	17	104	112	115	48	22	122	106	117	108	123	126
	Q	num Del	F4	F1	C	Y	num +	F9	F6	num Ent	F12	Pause
21	1	31	110	93	6	7	121	116	42	127	11	76
	~	A	Esc	num 1	%	6	F10	F5	#	L Wh	0	76
20	19	4	3	98	5	8	10	9	45	58	26	80
	E	#	W	num 2	\$	&	9	*	8	L Ctrl	BS	Home
19	16	2	18	83	20	23	25	57	24	92	27	86
	Tab	1-1	W	+	R	U	0	R Shift	K	num +		PgDn
18	30	114	32	103	34	37	39	44	38	79	40	85
	Caps	F3	S	num 3	F	J	L	L Shift	;	num +	:	PgUp
16	96	62	35	47	84	49	52	54	53	101	55	81
	num 8	R Alt	G	X	+	V	M	>	~	num 9	7	End
15	56	60	97	21	90	50	51	95	100	89	105	61
	*/	L Alt	T	num 5	num lk	B	N	num /	num *	num +	num -	Space

1&17 pin short circuit

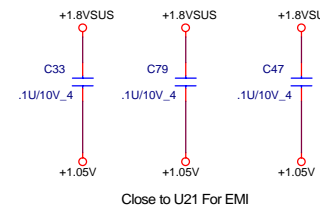

**PROJECT : QL6**  
Quanta Computer Inc.

Size Custom	Document Number	Rev 2A
<b>KB/FAN/POWER CONN/LED</b>		
Date: Tuesday, February 26, 2008	Sheet 29 of 40	

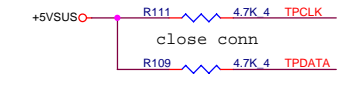
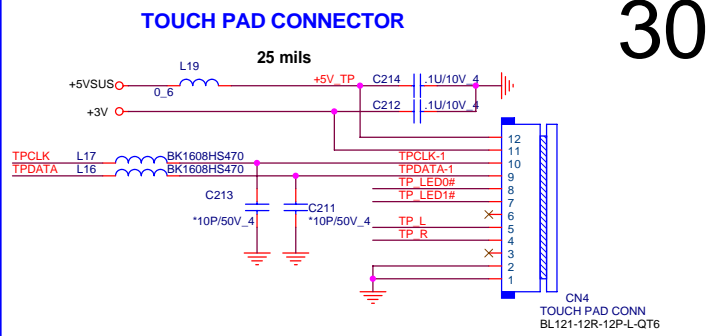
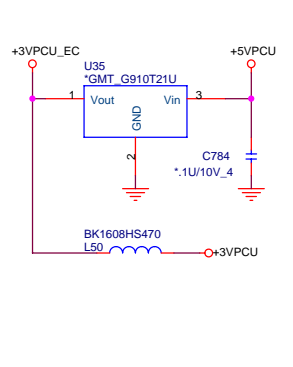
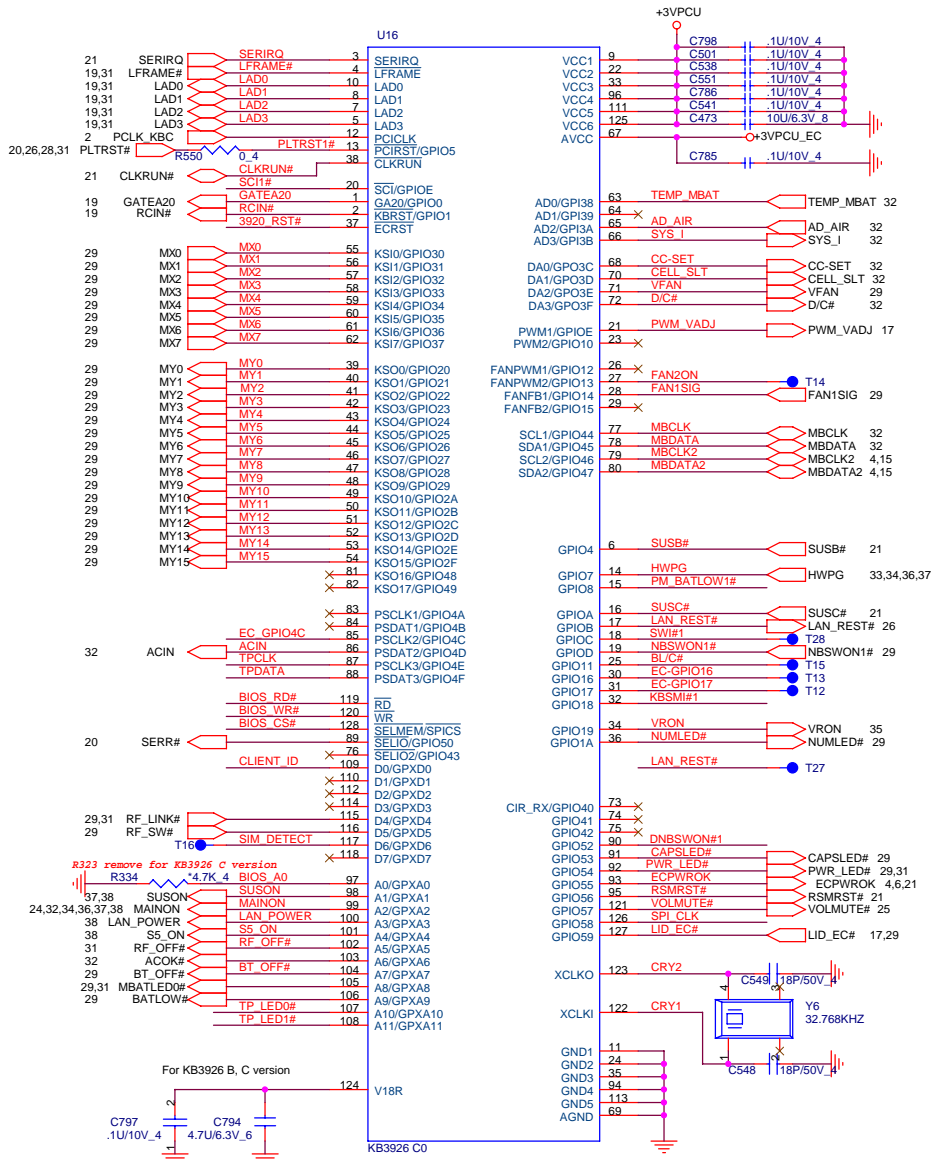

TOUCH PAD L/R

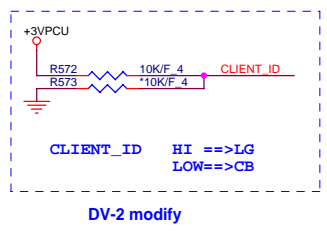
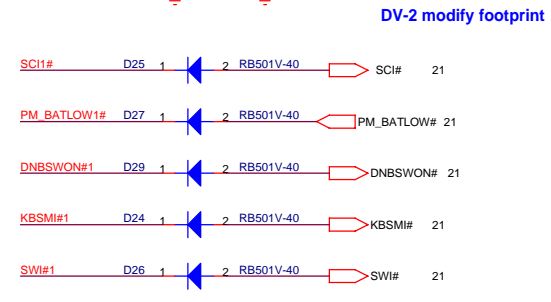
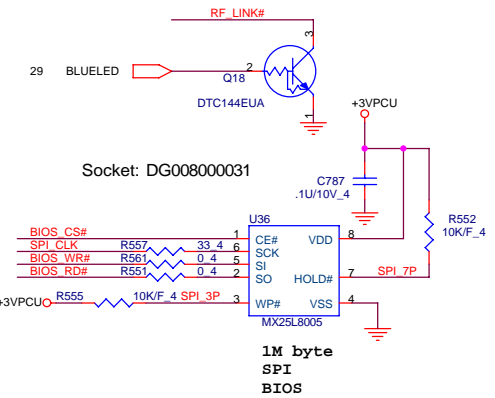
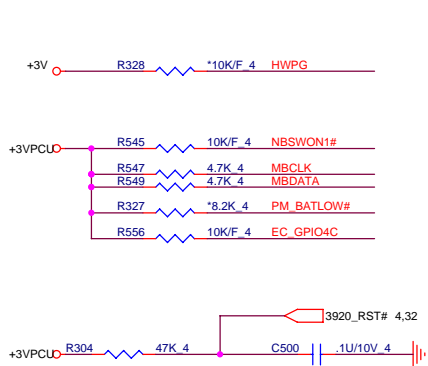
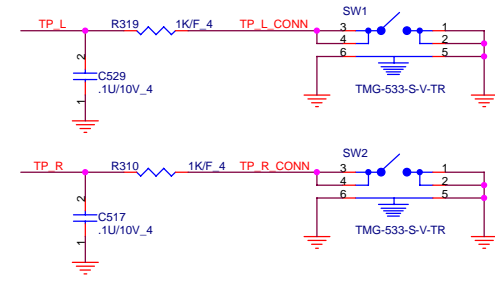

**NB5**

**PROJECT : QL6**  
Quanta Computer Inc.

Size Custom	Document Number	Rev 2A
	<b>KB3926/ROM/TP</b>	
Date: Tuesday, February 26, 2008	Sheet 30 of 40	

### Mini PCI-E Card 1 WLAN

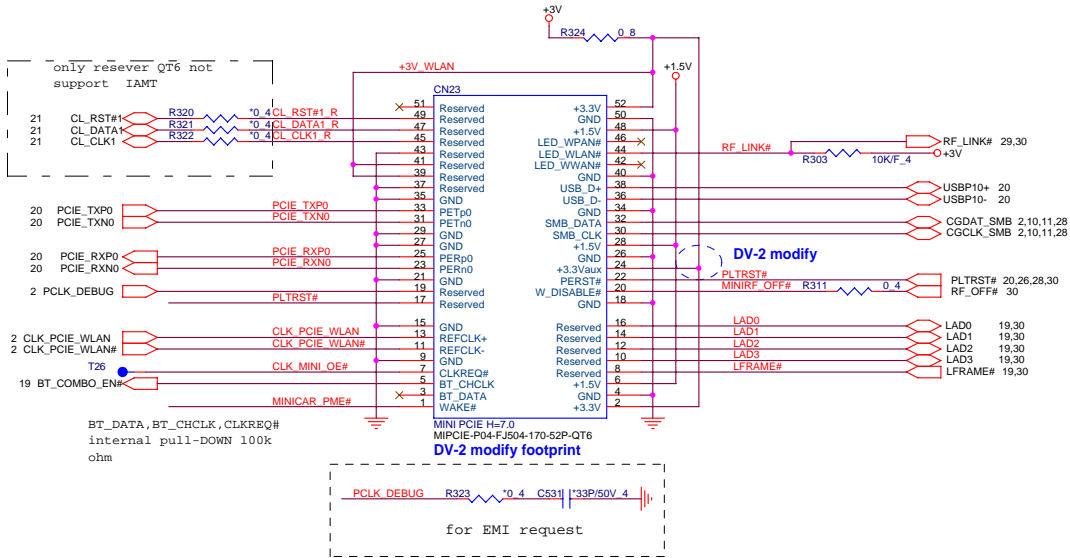

INTEL WLAN  
CARD PIN 20  
W\_DISABLE#  
have  
internal  
pull-up 110k  
ohm

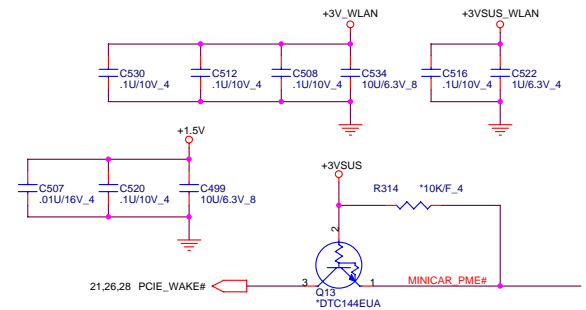

### Mini PCI-E Card 2 ROBSON

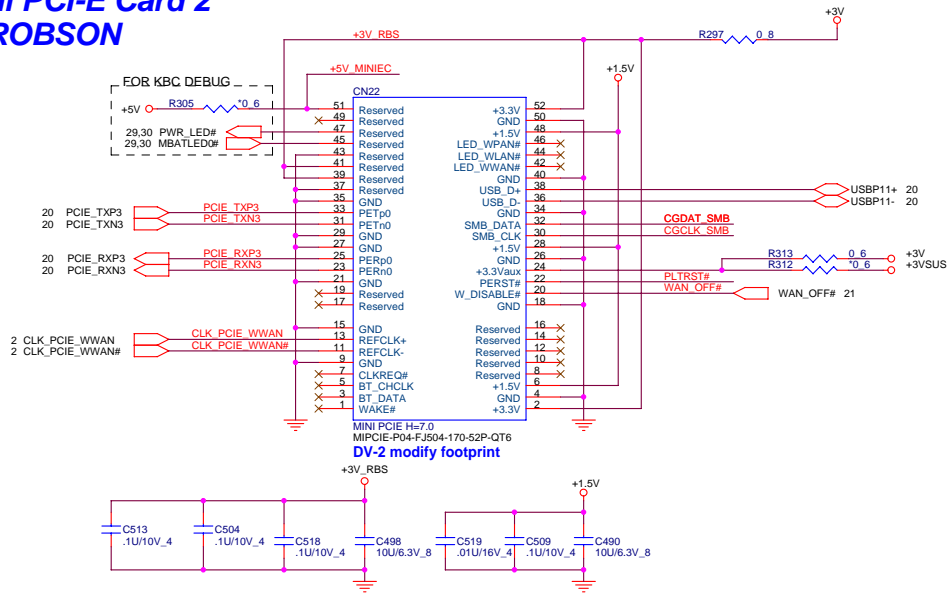

### E-SATA/USB COMBO

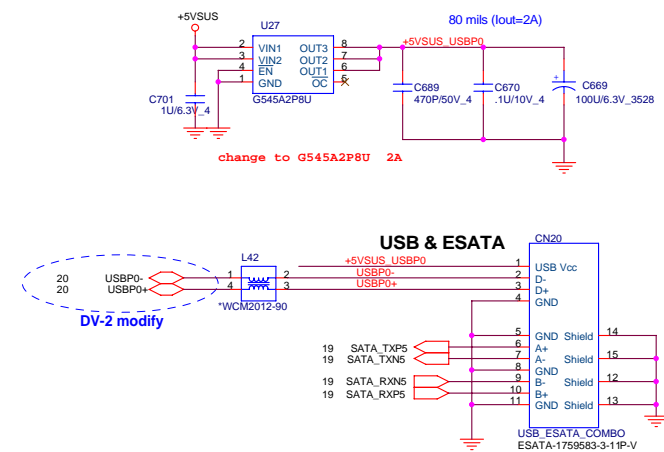

	<b>PROJECT : QL6</b> Quanta Computer Inc.	
	Size Custom	Document Number <b>MINI PCI-E CONN X2/E-SATA</b>
Date: Tuesday, February 26, 2008		Sheet 31 of 40

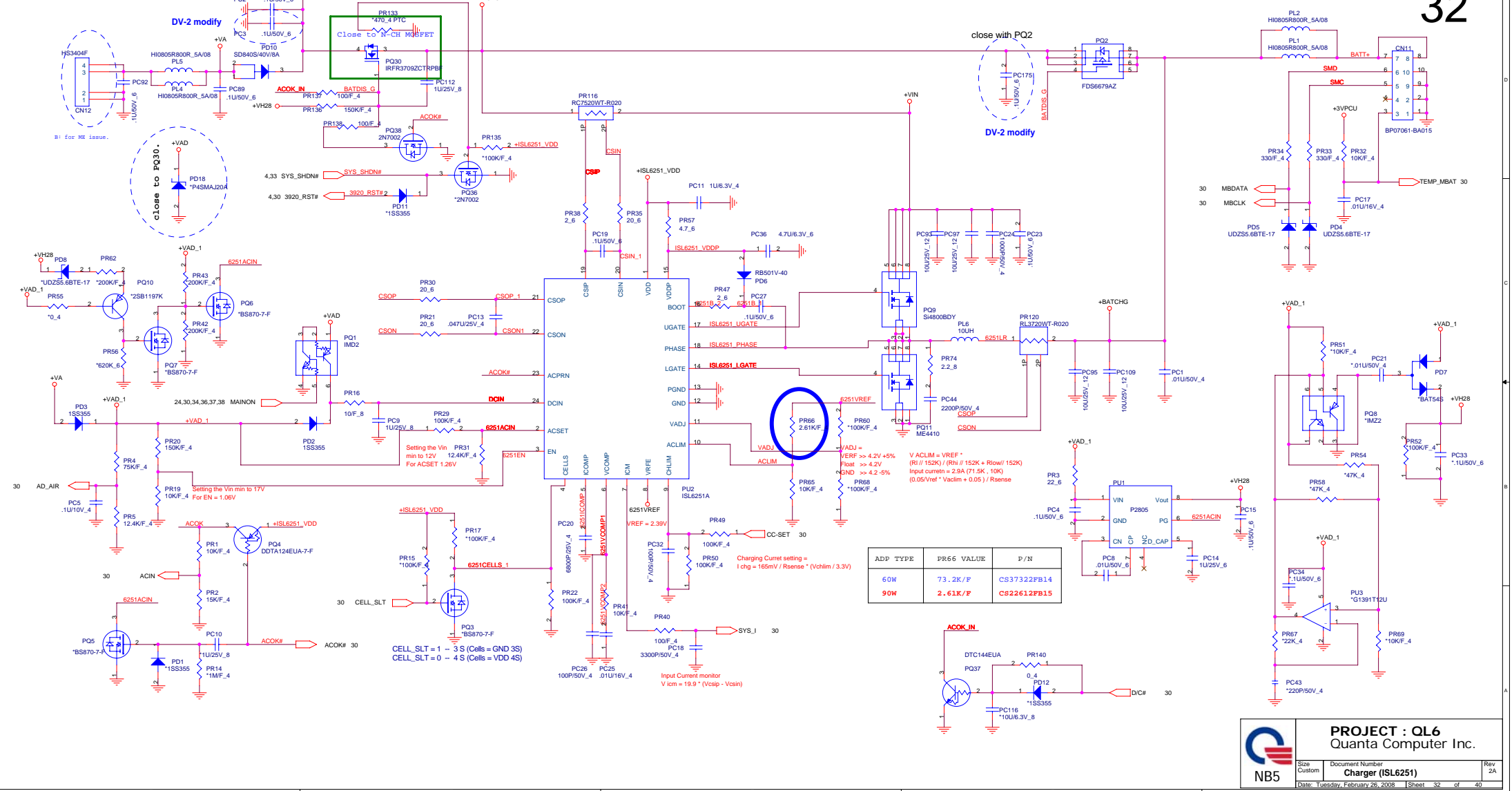

ADP TYPE	PR66 VALUE	P/N
60W	73.2K/F	CS37322FB14
90W	2.61K/F	CS22612PB15

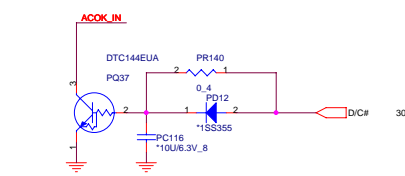

CELL\_SLT = 1 = 3 S (Cells = GND 3S)  
CELL\_SLT = 0 = 4 S (Cells = VDD 4S)

Input Current monitor  
 $V_{icm} = 19.9 \cdot (V_{csp} - V_{csin})$

$V_{ADJ} = V_{REF} \gg 4.2V + 5\%$   
 $Float \gg 4.2V$   
 $V_{GND} \gg 4.2 - 5\%$   
 $(0.05 \cdot V_{ref} \cdot V_{acim} + 0.05) / R_{sense}$

Setting the Vin min to 12V  
For ACSET 1.28V

Setting the Vin min to 17V  
For EN = 1.06V

**PROJECT : QL6**  
Quanta Computer Inc.

Size	Document Number	Rev
Custom	Charger (ISL6251)	2A
Date: Tuesday, February 26, 2008	Sheet	of 40



DC/DC +3V\_ALW/+5V\_ALW/+5V\_ALW2 /+12V\_ALW

5 Volt +/- 5%  
 Countinue current:5A  
 Peak current:7.5A  
 OCP minimum 10A

3.3 Volt +/- 5%  
 Countinue current:5A  
 Peak current:7.5A  
 OCP minimum 9A

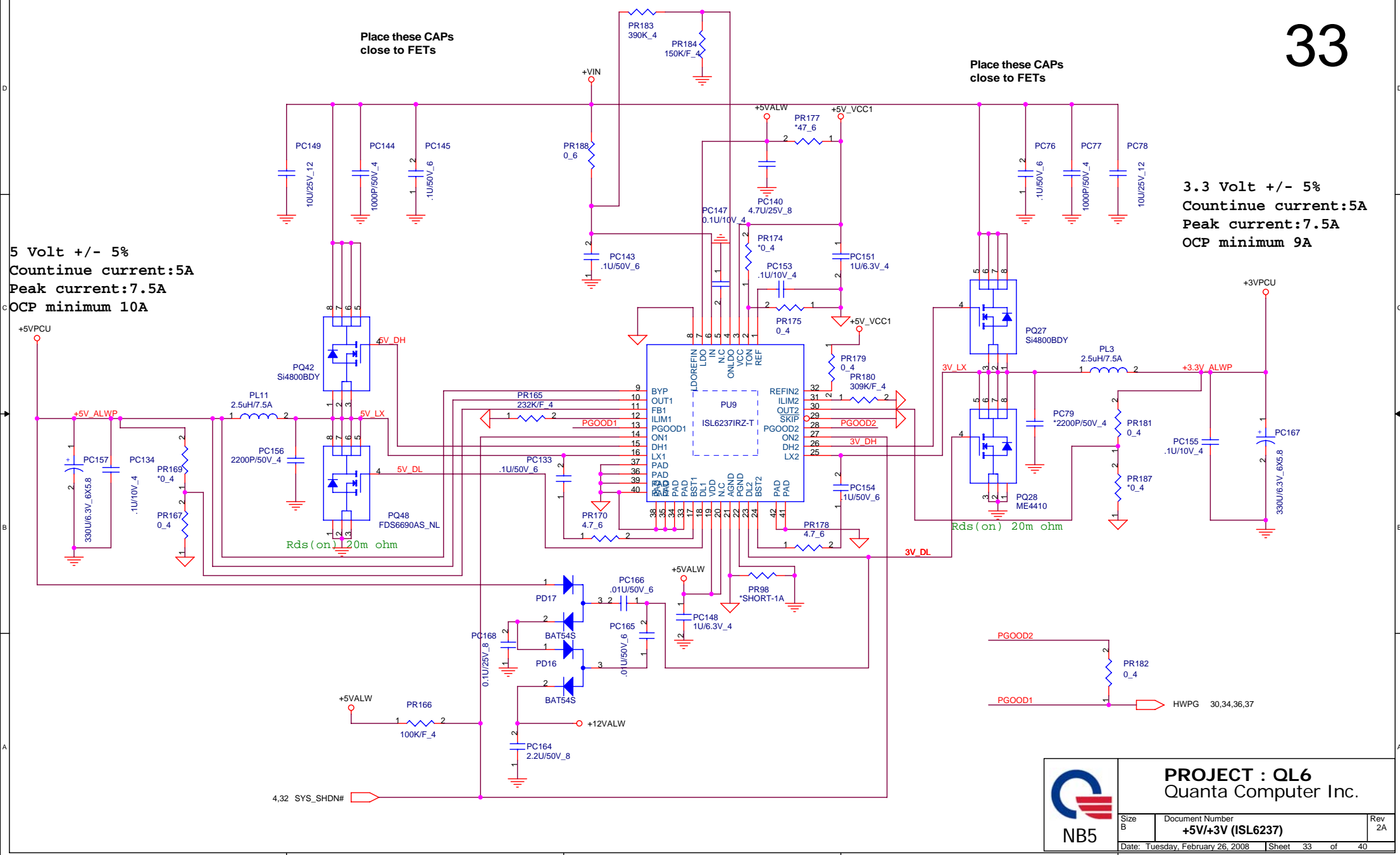

PROJECT : QL6 Quanta Computer Inc.		
Size B	Document Number <b>+5V/+3V (ISL6237)</b>	Rev 2A
Date: Tuesday, February 26, 2008 Sheet 33 of 40		

# VCCP1.05V & +1.5V

+1.05Volt +/- 5%  
 Countinue current:7.5A  
 Peak current:10A  
 OCP minimum 15A

# 34

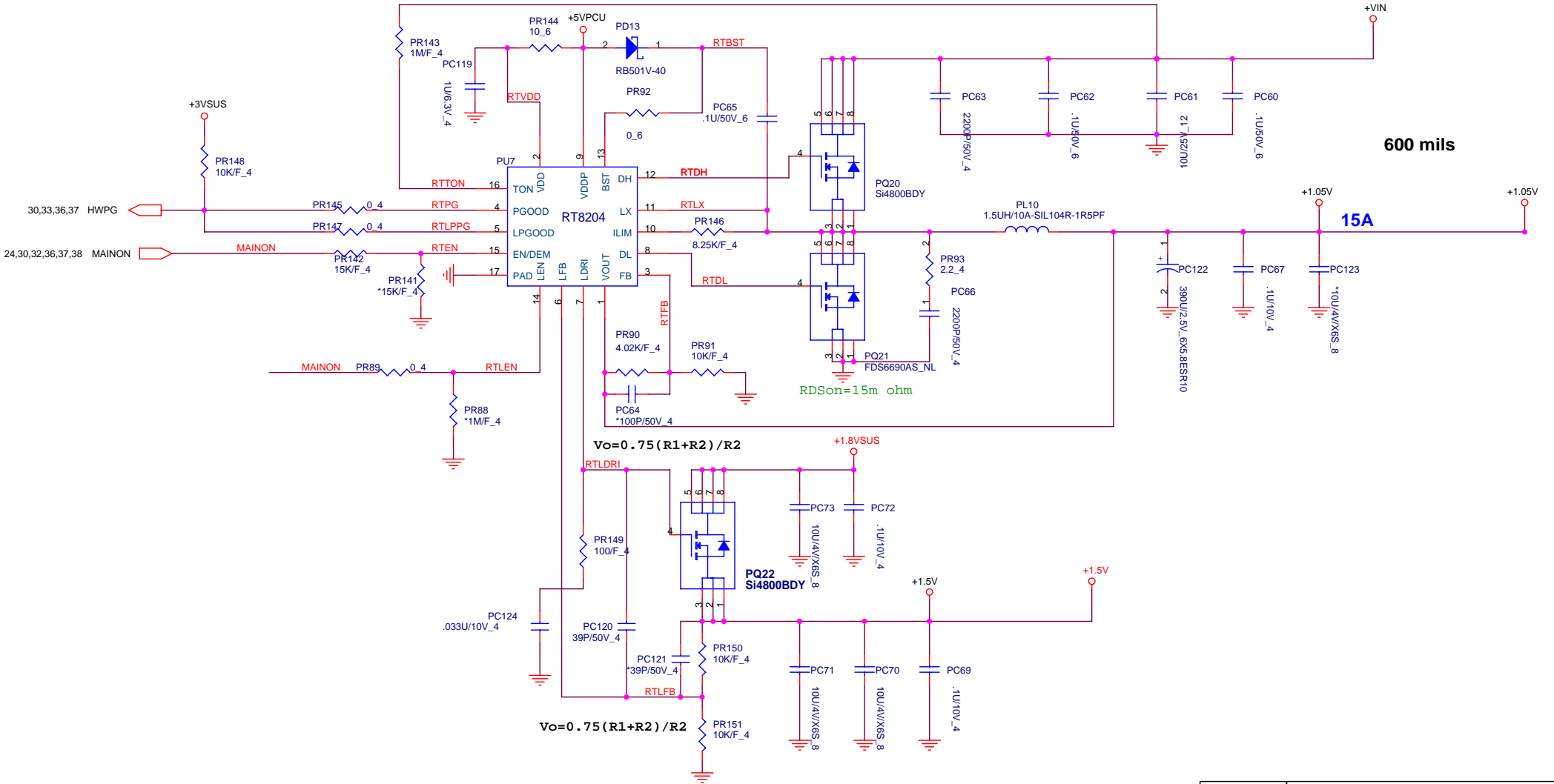

**PROJECT : QL6**  
 Quanta Computer Inc.

Size B	Document Number <b>+1.05V/+1.5V (RT8204)</b>	Rev 2A
Date: Tuesday, February 26, 2008		Sheet 34 of 40

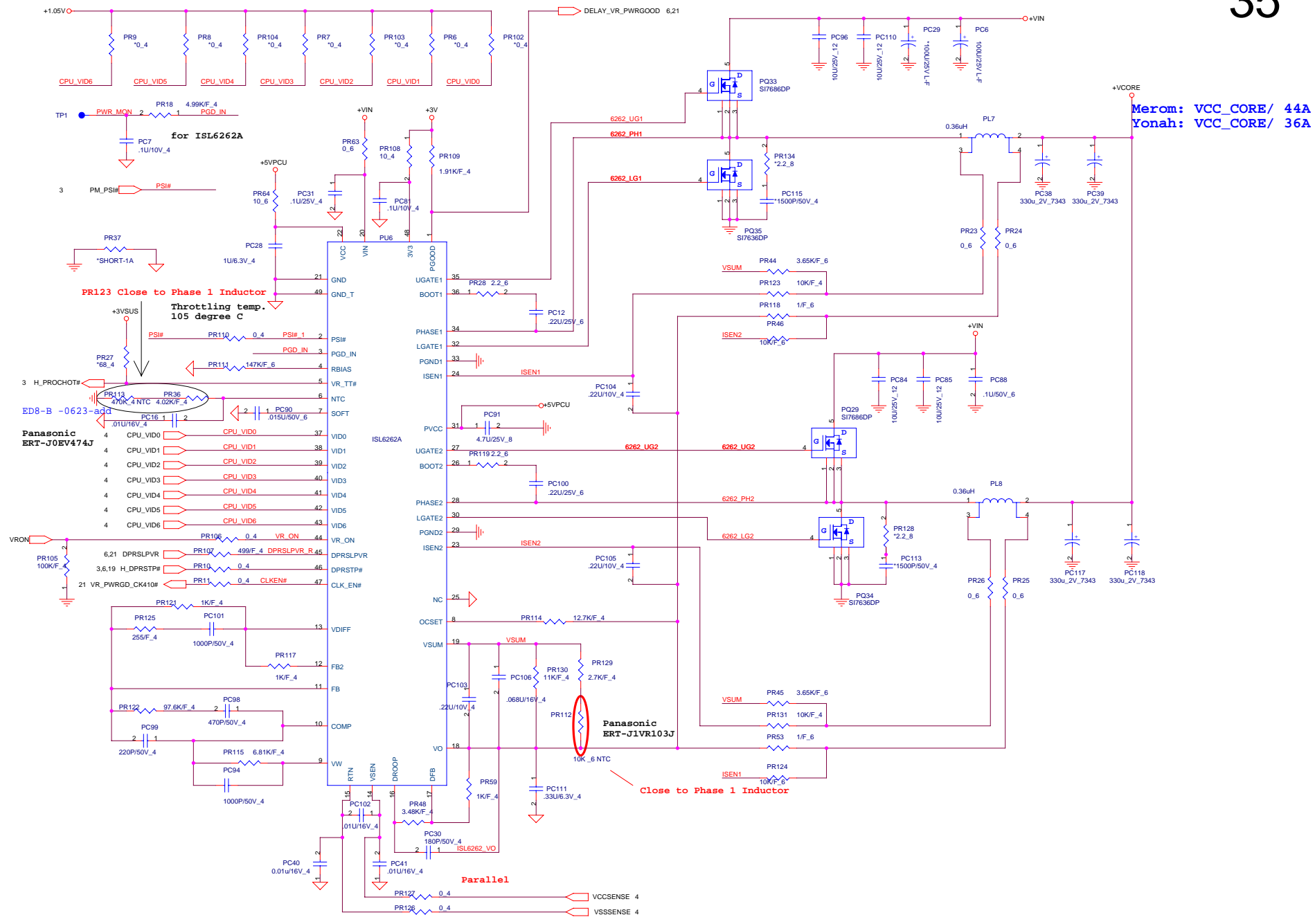

Merom: VCC\_CORE/ 44A  
 Yonah: VCC\_CORE/ 36A

	<b>PROJECT : QL6</b>	
	Quanta Computer Inc.	
	Size Custom	Document Number <b>CPU Core ( ISL6266A)</b>
Date: Tuesday, February 26, 2008 Sheet 35 of 40		

# VGA Core & VCC1.1

+1.1Volt +/- 5%  
 Countinue current:15A  
 Peak current:17A  
 OCP minimum 22A

# 36

PC174

0.22U --> 3ms  
 1U --> 15ms

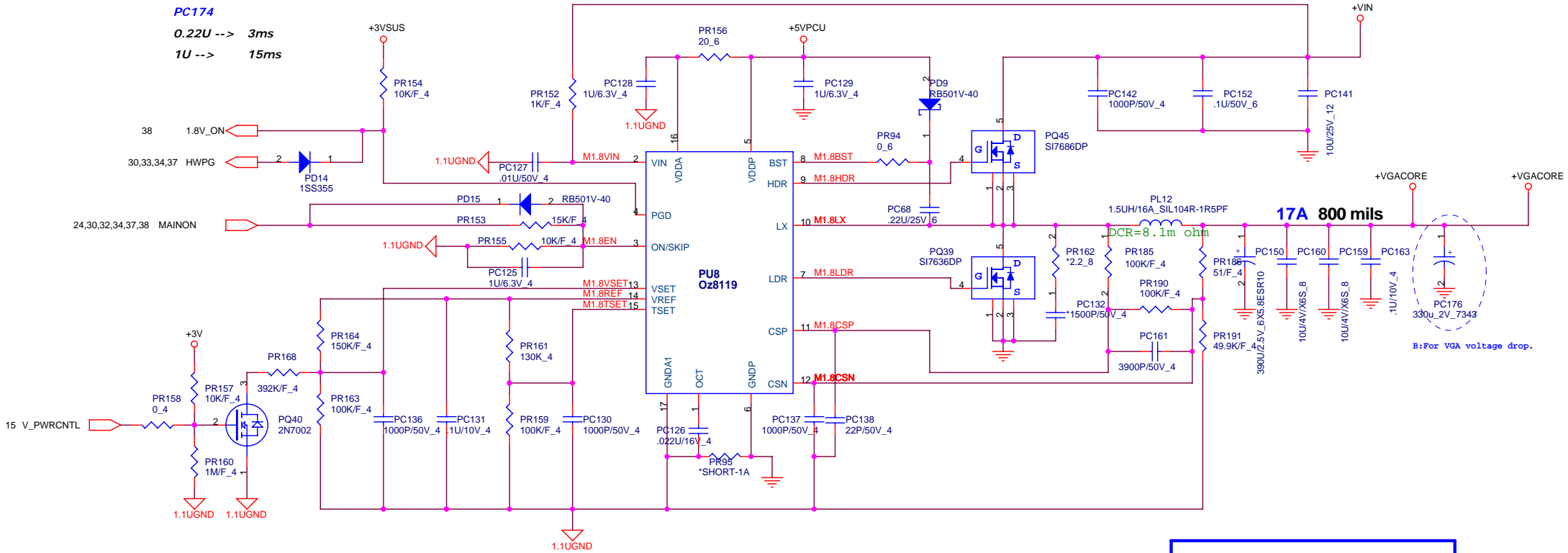

V_PWRCNTL	NVIDIA NB9M	Resistor Value
HI	0.90V	PR67_392K_CS43922FB17
LO	1.09V	PR55_150K_CS41502FB18

V_PWRCNTL	nVIDIA NB9P-GE2	Resistor Value
HI	1.15V	PR67_1.43M_CS51432FB10
LO	1.2V	PR55_130K_CS41302FB00

V_PWRCNTL	NVIDIA NB9M-GE	Resistor Value
HI	0.95V	PR67_402K_CS44022FB25
LO	1.09V	PR55_150K_CS41502FB18

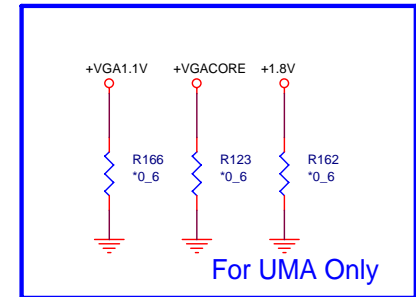

**PROJECT : QL6**  
 Quanta Computer Inc.

Size B	Document Number <b>VGA CORE OZ8118</b>	Rev 2A
Date: Tuesday, February 26, 2008 Sheet 36 of 40		

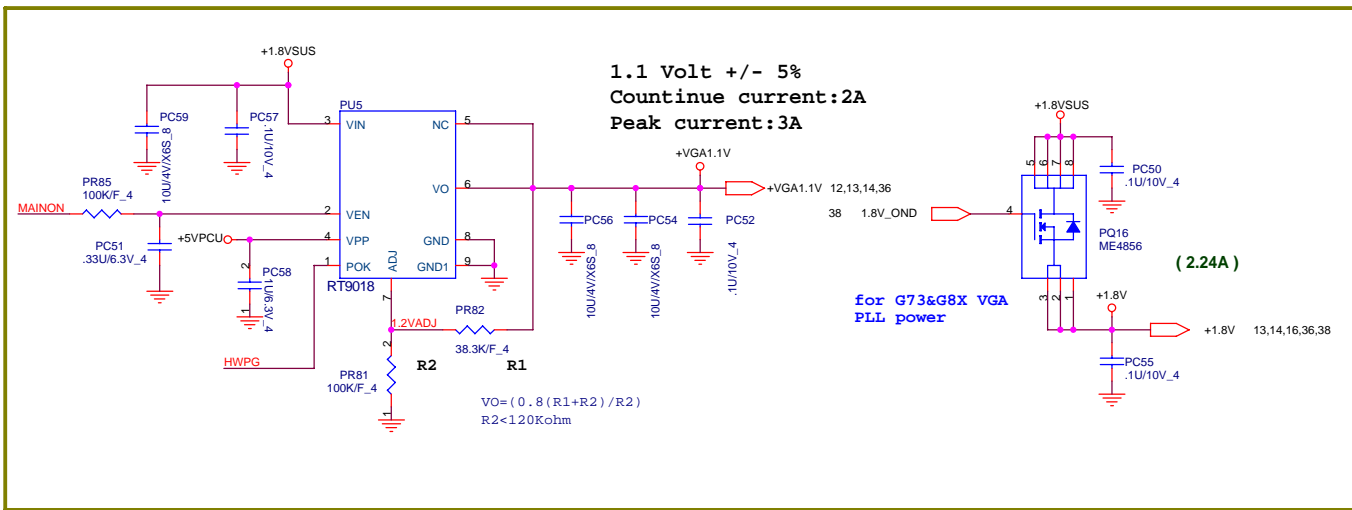
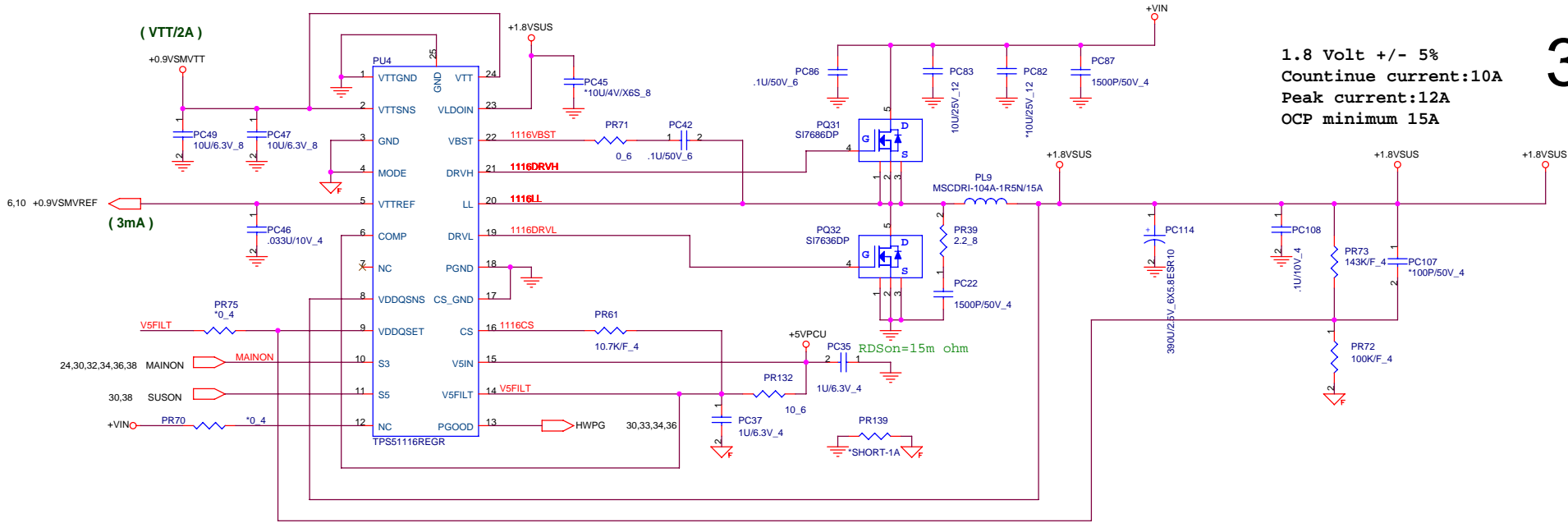

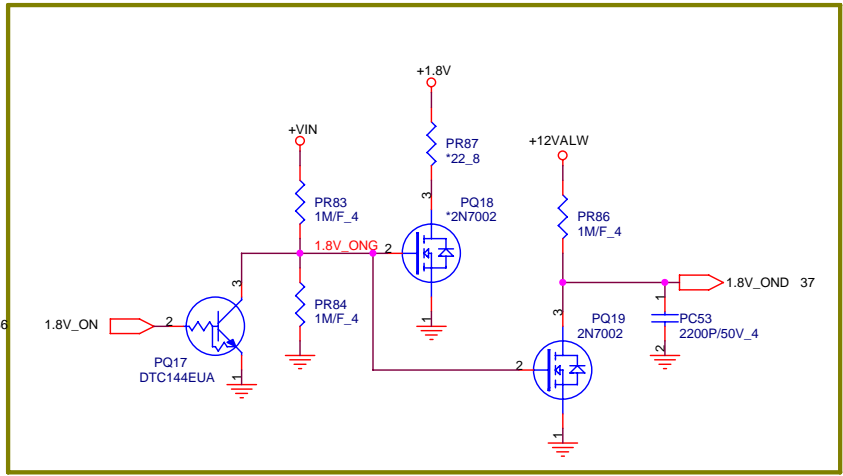
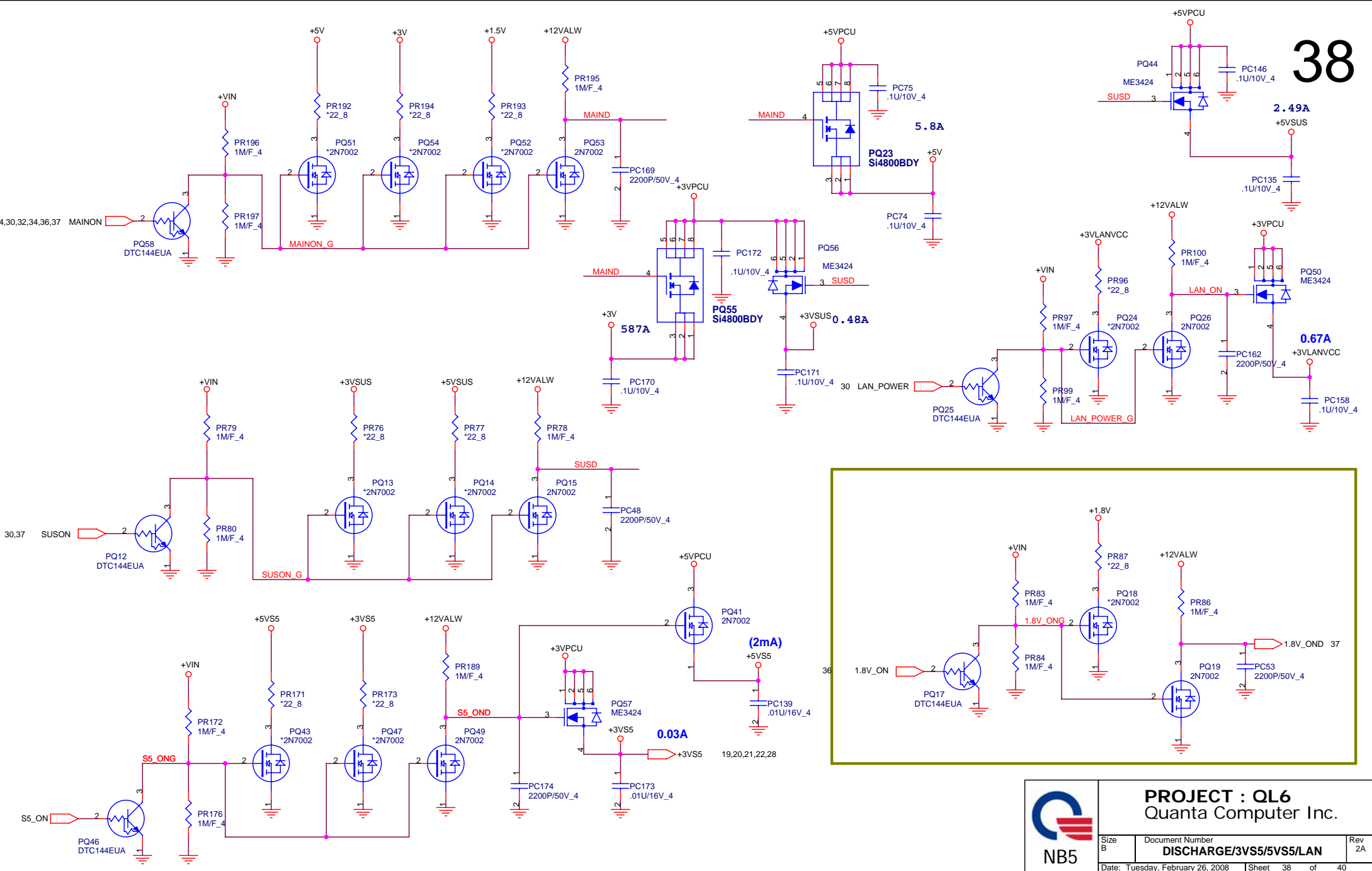

**PROJECT : QL6**  
**Quanta Computer Inc.**

Size B	Document Number <b>DISCHARGE/3VS5/5VS5/LAN</b>	Rev 2A
Date: Tuesday, February 26, 2008		Sheet 38 of 40

	Voltage level	AC MODE				DC MODE			
		S0	S3	S4	S5	S0	S3	S4	S5
+3VPCU	3.3V +/- 5%	V	V	V	V	V	V	V	V
+5VPCU	5V +/- 5%	V	V	V	V	V	V	V	V
+3VRTC	3.3V +/- 5%	V	V	V	V	V	V	V	V
+3VSS	3.3V +/- 5%	V	V	V	V	V	V		
+5VSS	5V +/- 5%	V	V	V	V	V	V		
+3VSUS	3.3V +/- 5%	V	V			V	V		
+5VSUS	5V +/- 5%	V	V			V	V		
+1.8VSUS	1.8V +/- 5%	V	V			V	V		
+0.9VSMVTT	0.9V +/- 5%	V	V			V	V		
+1.5V	1.5V +/- 5%	V				V			
+1.05V	1.05V +/- 5%	V				V			
+VCORE	0.9~1.15V	V				V			
+VGA_CORE	0.9~1.2V	V				V			
+VGA1.1V	1.1V +/- 5%	V				V			
+1.8V	1.8V +/- 5%	V				V			
+3VLAVCC	3.3V +/- 5%	V				V			

Вы скачали этот файл с сайта «Сайт радиолюбителей»



## Другие разделы сайта

### Раздел БИБЛИОТЕКА

Книги для и журналы радиолюбителям

<http://radio-uchebnik.ru/library/>

### Раздел РАДИОСХЕМЫ

Различные схемы как для начинающих так и для профессионалов:

Схемы бытовой техники, телевизоров, мониторов, автомагнитол, музыкальных центров, и для самостоятельной сборки

<http://radio-uchebnik.ru/shem/>

### Раздел ФАЙЛОВОЕ ХРАНИЛИЩЕ

Различные файлы: Даташиты, схемы, прошивки и так далее

<http://radio-uchebnik.ru/downfiles/>

### Раздел РАДИОКОМПАС

Если Вы занимаетесь ремонтом электроники на профессиональном уровне- то Вы можете сообщить о себе.

<http://radio-uchebnik.ru/radiomap/>

### Раздел ДОСКА ОБЪЯВЛЕНИЙ

Здесь Вы можете разместить бесплатное объявление сроком до 120 дней (только радиотематика!!)

<http://radio-uchebnik.ru/ads/>

### Раздел СПРАВОЧНИК ПО МИКРОСХЕМАМ

Справочные данные на микросхемы импортного и отечественного производства

<http://radio-uchebnik.ru/microbase/>

### Раздел СТАТЬИ

Различные статьи радиолюбительской (и не только) тематики: секреты телемастера, практическая электроника, альтернативная энергия, расчеты по электронике, электронные устройства и так далее

<http://radio-uchebnik.ru/txt/>

### ФОРУМ НАШЕГО САЙТА

<http://radio-uchebnik.ru/forum/>